TABLE OF CONTENTS

1

SECTION I: INVITATION FOR BIDS.....2

SECTION II: INSTRUCTIONS TO TENDERER 4

SECTION III: TENDER DATA SHEET 7

SECTION IV: GENERAL CONDITIONS OF CONTRACT... ..

SECTION V: CONTRACT DATA SHEET..... 45

SECTION VI: SPECIFICATIONS 81

SECTION VIII: BILL OF QUANTITIES•

SECTION IX: TENDER FORMS.....236

SECTION X: FORMS OF SECURITY251

ABBREVIATIONS AND ACRONYMS 2

CDS	Contract Data Sheet
GCC	General Conditions of Contract
IFT	Invitation for Tender
ITT	Instruction to Tenderers
PE	Procuring Entity
PM	Contract Administrator

PPADA 2015 Public Procurement and Asset Disposal Act, 2015

PPADR 2020 Public Procurement and Asset Disposal Regulations, 2020

PPOA	Public Procurement Oversight Authority
STD	Standard Tender Documents
SOR	Statement of Requirements
SP	Service Provider
TDS	Tender Data Sheet
VAT	Value Added Tax

SECTION II: INSTRUCTIONS TO TENDERERS (ITT)

Table of Contents

4

SECTION II: INSTRUCTIONS TO TENDERERS (ITT).....	7
A. Introduction.....	10
1. Scope of Tender	10
2. Source of Funds	10
3. Eligible Tenderers	10
4. One Tender per Tenderer.....	12
5. Alternative Tenders by Tenderers.....	12
6. Cost of Tendering.....	12
7. Site Visit and Pre-Tender Meeting.....	12
B. Tendering Documents	13
8. Content of Tendering Documents	13
9. Clarification of Tendering Documents.....	14
10. Amendments of the Tendering Documents	15
C. Preparation of Tenders	15
11. Language of Tender	15
12. Documents Constituting the Tender.....	15
13. Documents Establishing Eligibility and Qualifications of the Tenderer.....	16
14. Lots Package.....	17
15. Form of Tender	17
16. Tender Prices	17
17. Tender Currencies	18
18. Tender Validity Period	18
19. Tender Security and Tender Securing Declaration	19
20. Format and Signing of Tender.....	21
D. Submission of Tenders.....	21
21. Sealing and Marking of Tenders.....	21
22. Deadline for Submission of Tenders.....	22
23. Late Tenders	22
24. Modification, Substitution and Withdrawal of Tenders.....	22
E. Opening and Evaluation of Tenders.....	23
25. Opening of Tenders.....	23
26. Confidentiality.....	25
27. Clarification of Tenders.....	25
28. Preliminary Examination of Tenders	26
29. Correction of Errors	27
30. Conversion to Single Currency.....	27
31. Comparison of Tenders	28
32. National Preference	28
33. Determination of the Lowest Evaluated Tender	29
34. Post-qualification of Tenderer	29
F. Award of Contract.....	29
35. Criteria of Award	29
36. Clarifications.....	30
37. Procuring Entity's Right to Accept any Tender and to Reject any or all Tenders.....	31
38. Procuring Entities Right to Vary Quantities at the Time of Award.....	31
39. Notification of Award.....	31
40. Signing of Contract	32
41. Performance Security	32

42. Advance Payment	9	33
43. Adjudicator		33
G. Table of Clauses	5	
Review of Procurement Decisions.....		34
44. Right to Review		34
45. Time Limit on Review		34
46. Submission of Applications for Review by the Public Procurement Administrative Review Board		34
47. Decision by the Public Procurement Administrative Review Board.....		35
48. Appeal on the decision of the Review Board.....		35

A. Introduction

- | | |
|------------------------------|--|
| 1. Scope of Tender | <p>1.1 The Procuring Entity indicated in the Tender Data Sheet (TDS) invites Tenders for the construction of works as specified in the Tender Data Sheet and Sections VI (Technical Specifications) and VII (Drawings).</p> <p>1.2 The successful Tenderer will be expected to complete the works by the required completion date specified in the Tender Data Sheet.</p> <p>1.3 The objectives of the works are listed in the Tender Data Sheet. These are mandatory requirements. Any subsequent detail is offered to support these objectives and must not be used to dilute their importance.</p> |
| 2. Source of Funds | <p>2.1 The Government of Kenya through Ministry of Water and irrigation received a funds from the GOK towards the cost of the Project named in the Tender Data Sheet.</p> <p>2.2 Payments will be made directly by the Procuring Entity (or by financing institution specified in the Tender Data Sheet upon request of the Procuring Entity to so pay) and will be subject in all respects to the terms and conditions of the resulting contract placed by the Procuring Entity.</p> |
| 3. Eligible Tenderers | <p>3.1 A Tenderer may be a natural person, private or public company, government-owned institution, subject to sub-Clause 3.4 or any combination of them with a formal intent to enter into an agreement or under an existing agreement in the form of a joint venture, consortium, or association. In the case of a joint venture, consortium, or association, unless otherwise specified in the Tender Data Sheet, all parties shall be jointly and severally liable.</p> <p>3.2 The Invitation for Tenders is open to all suppliers as defined in the Public Procurement and Asset Disposal Act, 2015 and the Public Procurement and Asset Disposal Regulations, 2020 except as provided hereinafter.</p> <p>3.3 National Tenderers shall satisfy all relevant licensing and/or registration with the appropriate statutory bodies in Kenya, such as the Ministry of Public Works or the Energy Regulatory Commission.</p> <p>3.4 A Tenderer shall not have a conflict of interest. All Tenderers found to have a conflict of interest shall be disqualified. A Tenderer may be considered to have a conflict of interest with one or more parties in this Tendering process, if they:</p> |

- a) Are associated or have been associated in the past directly or indirectly with employees or agents of the Procuring Entity or a member of a board or committee of the Procuring Entity;
 - b) Are associated or have been associated in the past, directly or indirectly with a firm or any of its affiliates which have been engaged by the Procuring Entity to provide consulting services for the preparation of the design, specifications and other documents to be used for the procurement of the works under this Invitation for Tenders;
 - c) Have controlling shareholders in common; or
 - d) Receive or have received any direct or indirect subsidy from any of them; or
 - e) Have the same legal representative for purposes of this Tender; or
 - f) Have a relationship with each other, directly or through common third parties, that puts them in a position to have access to information about or influence on the Tender of another Tenderer, or influence the decisions of the Procuring Entity regarding this Tendering process; or
 - g) Submit more than one Tender in this Tendering process, However, this does not limit the participation of subcontractors in more than one Tender, or as Tenderer and subcontractor simultaneously.
- 3.5** A Tenderer will be considered to have a conflict of interest if they participated as a consultant in the preparation of the design or technical specification of the project and related services that are the subject of the Tender.
- 3.6** Tenderers shall not be under a declaration of ineligibility for corrupt and fraudulent practices issued by the Government of Kenya in accordance with GCC sub-Clause 3.2.
- 3.7** Government owned enterprises in Kenya may participate only if they are legally and financially autonomous, if they operate under commercial law, are registered by the relevant registration board or authorities and if they are not a dependent agency of the Government.
- 3.7** Tenderers shall provide such evidence of their continued eligibility satisfactory to the Procuring Entity, as the Procuring Entity shall reasonably request.

- 4. One Tender per Tenderer**
- 4.1** A firm shall submit only one Tender, in the same Tendering process, either individually as a Tenderer or as a partner in a joint venture pursuant to ITT Clause 5.
- 4.2** No firm can be a subcontractor while submitting a Tender individually or as a partner of a joint venture in the same Tendering process.
- 4.3** A firm, if acting in the capacity of subcontractor in any Tender, may participate in more than one Tender but only in that capacity.
- 4.4** A Tenderer who submits or participates in more than one Tender (other than as a subcontractor or in cases of alternatives that have been permitted or requested) will cause all the Tenders in which the Tenderer has participated to be disqualified.
- 5. Alternative Tenders by Tenderers**
- 5.1** Tenderers shall submit offers that comply with the requirements of the Tendering documents, including the basic Tenderer's technical design as indicated in the specifications and Drawings and Bill of Quantities. Alternatives will not be considered, unless specifically allowed for in the **Tender Data Sheet**. If so allowed, sub-Clause 5.2 and 5.3 shall govern.
- 5.2** When alternative times for completion are explicitly invited, a statement to that effect will be included in the **Tender Data Sheet** as will the method of evaluating different times for completion.
- 5.3** If so allowed in the **Tender Data Sheet**, Tenderers wishing to offer technical alternatives to the requirements of the Tendering documents must also submit a Tender that complies with the requirements of the Tendering documents, including the basic technical design as indicated in the specifications. In addition to submitting the basic Tender, the Tenderer shall provide all information necessary for a complete evaluation of the alternative by the Procuring Entity, including technical specifications, breakdown of prices, and other relevant details. Only the technical alternatives, if any, of the lowest evaluated Tenderer conforming to the basic technical requirements shall be considered by the Procuring Entity.
- 6. Cost of Tendering**
- 6.1** The Tenderer shall bear all costs associated with the preparation and submission of its Tender, and the Procuring Entity shall in no case be responsible or liable for those costs, regardless of the conduct or outcome of the Tendering process.
- 7. Site Visit and Pre-Tender Meeting**
- 7.1** The Tenderer, at the Tenderer's own responsibility and risk, is advised to visit and examine the Site of Works and its surroundings and obtain all information that may be necessary for preparing the Tender and entering into a contract for construction of the Works.

The costs of visiting the Site shall be at the Tenderer's own expense.

- 7.2** The Procuring Entity may conduct a site visit and a pre-Tender meeting. The purpose of the pre-Tender meeting will be to clarify issues and to answer questions on any matter that may be raised at that stage.
- 7.3** The Tenderer's designated representative is invited to attend a site visit and pre-Tender meeting which, if convened, will take place at the venue and time stipulated in the **Tender Data Sheet**.
- 7.4** The Tenderer is requested as far as possible, to submit any questions in writing or by electronic means to reach the procuring Entity before the pre-Tender meeting. It may not be practicable at the meeting to answer all questions, but questions and responses will be transmitted in accordance with sub-Clause 7.5.
- 7.5** Minutes of the pre-Tender meeting, including the text of the questions raised and the responses given together with any responses prepared after the pre-Tender meeting will be transmitted within the time stated in the **Tender Data Sheet** to all purchasers of the Tendering documents. Any modification of the Tendering documents listed in sub-Clause 8.1 that may become necessary as a result of the pre-Tender meeting shall be made by the Procuring Entity exclusively through the issue of an Addendum pursuant to ITT sub Clause 10.2 and not through the minutes of the pre-Tender meeting.
- 7.6** Non attendance during the site visit or Pre-Tender meeting will not be a cause for disqualification of a Tenderer unless specified to the contrary in the **Tender Data Sheet**.

B. Tendering Documents

8. Content of Tendering Documents

- 8.1** The works required, tendering procedures, and contract terms are prescribed in the Tendering Documents. In addition to the Section I Invitation for Tenders, tendering documents which should be read in conjunction with any addenda issued in accordance with ITT sub Clause 10.2 include:

Section II	Instructions to Tenderers
Section III	Tender Data Sheet
Section IV	General Conditions of Contract
Section V	Contract Data Sheet
Section VI	Specifications
Section VII	Drawings
Section VIII	Bill of Quantities

Section IX Forms of Tender

- Form of Tender
- Appendix to Tender
- Confidential Business Questionnaire
- Integrity Declaration
- Letter of Acceptance
- Form of Contract Agreement

Section X Forms of Security

- Tender Security Form
- Tender Securing Declaration
- Performance Bank or Insurance Guarantee
- Advance Payment Guarantee

Section XI Form RB 1 Application to Public Procurement
Administrative Review Board

- 8.2** The number of copies to be completed and returned with the Tender is specified in the **Tender Data Sheet**.
- 8.3** The Invitation for Tenders (Section I) issued by the Procuring Entity is not part of the Tendering Documents and is included for reference purposes only. In case of discrepancies between the Invitation for Tenders and the Tendering Documents listed in sub-Clause 8.1 above, the said Tendering Documents will take precedence.
- 8.4** The Procuring Entity is not responsible for the completeness of the Tendering Documents and their addenda, if they were not obtained directly from the authorized staff of the Procuring Entity.
- The Tenderer is expected to examine all instructions, forms, terms and specifications in the Tendering documents. Failure to
- 8.5** furnish all information required by the Tendering Documents or to submit a Tender substantially responsive to the Tendering documents in every respect will be at the Tenderer's risk and may result in the rejection of its Tender.

9. Clarification of Tendering Documents

- 9.1** A prospective Tenderer requiring any clarification of the Tendering documents may notify the Procuring Entity in writing, e-mail or facsimile at the Procuring Entity's address indicated in the **Tender Data Sheet**.
- 9.2** The Procuring Entity will within the period stated in the **Tender Data Sheet** respond in writing to any request for clarification provided that such request is received no later than the period indicated in the **Tender Data Sheet** prior to the deadline for the submission of Tenders prescribed in sub-Clause 22.1.

9.3 Copies of the procuring entity's response will be forwarded to all Purchasers of the Tendering documents, including a description of the inquiry, but without identifying its source.

9.4 Should the Procuring Entity deem it necessary to amend the Tendering documents as a result of a clarification, it shall do so following the procedure under ITT Clause 10.

10. Amendments of the Tendering Documents

10.1 Before the deadline for submission of Tenders, the Procuring Entity may, for any reason, whether at its own initiative or in response to a clarification requested by a prospective Tenderer, modify the Tendering documents by issuing addenda.

10.2 Any addendum issued shall be part of the Tender documents pursuant to sub-Clause 8.1 and shall be communicated in writing, by e-mail or facsimile to all who have obtained the Tendering documents directly from the Procuring Entity.

10.3 In order to allow prospective Tenderers reasonable time in which to take an addendum into account in preparing their Tenders, the Procuring Entity at its discretion shall extend, as necessary, the deadline for submission of Tenders, in accordance with sub-Clause 22.2

C. Preparation of Tenders

11. Language of Tender

11.1 The Tender, and all correspondence and documents related to the Tender exchanged by the Tenderer and the Procuring Entity shall be written in the Tender language stipulated in the **Tender Data Sheet**. Supporting documents and printed literature furnished by the Tenderer may be in another language provided they are accompanied by an accurate translation of the relevant passages in the above stated language, in which case, for purposes of interpretation of the Tender, the translation shall prevail.

12. Documents Constituting the Tender

12.1 The Tender submitted by the Tenderer shall consist of the following components:

- a) The Form of Tender (in the format indicated in Section IX) completed in accordance with ITT Clause 15, 16 and 17;
- b) Information requested by Instructions to Tenderers ITT sub-Clause 13.2; 13.3 and 13.4;
- c) Tender Security or Tender Securing Declaration in accordance with Instructions to Tenderers ITT Clause 19;

- d) Priced Bill of Quantities;
- e) Qualification Information Form and Documents;
- f) Alternative offers where invited in accordance with Instructions to Tenderers ITT Clause 5;

- g) Written confirmation authorizing the signatory of the Tender to commit the Tenderer in accordance with Instructions to Tenderers ITT sub Clause 19.2; and

- h) And any information or other materials required be completing and submitting by Tenderers, as specified in the **Tender Data Sheet**.

13. Documents Establishing Eligibility and Qualifications of the Tenderer

- 13.1** Pursuant to ITT Clause 13, the Tenderer shall furnish, as part of its Tender, documents establishing the Tenderer's eligibility to Tender and its qualifications to perform the contract if its Tender is accepted.
- 13.2** In the event that pre-qualification of potential Tenderers has been undertaken, only Tenders from pre-qualified Tenderers will be considered for award of contract. These qualified Tenderers should submit their Tenders with any information updating the original pre-qualification applications or, alternatively, confirm in their Tenders that the originally submitted pre-qualification information remains essentially correct as of the date of Tender submission. The update or confirmation should be provided in Section IX.
- 13.3** If the Procuring Entity has not undertaken pre-qualification of potential Tenderers, to qualify for award of the contract, Tenderers shall meet the minimum qualifying criteria specified in the **Tender Data Sheet**:
- 13.4** Tenders submitted by a joint venture of two or more firms as partners shall comply with the following requirements, unless otherwise stated in the **Tender Data Sheet**:
- a) The Tender shall include all the information listed in the **Tender Data Sheet** pursuant to sub-Clause 13.3 above for each joint venture partner;
 - b) The Tender shall be signed so as to be legally binding on all partners;
 - c) One of the partners will be nominated as being in charge, and this authorization shall be evidenced by submitting a power of attorney signed by legally authorized signatories of all the partners;
 - d) The partner in charge shall be authorized to incur liabilities and receive instructions for and on behalf of any and all partners of a joint venture and the entire execution of the Contract, including payment, shall be done exclusively with the partner in charge;
 - e) All partners of the joint venture shall be liable jointly and severally for the execution of the contract in accordance with the contract terms and a statement to this effect shall be included in the authorization mentioned under (c) above as well as in the Tender and in the Agreement (in case of a successful Tender); and
 - f) A copy of the joint venture agreement entered into by all partner shall be submitted with the Tender. Alternatively, a Letter of Intent to execute a joint venture agreement in the event of a successful Tender shall be signed by all partners and submitted with the Tender, together with a copy of the proposed Agreement.
 - g) The Tender Security and Tender Securing Declaration as stated in accordance with ITT Clause 19, and in case of a successful Tender, the Agreement, shall be signed so as to be legally binding on all partners.

- 14. Lots Package**
- 14.1** When Tendering for more than one contract under the lots arrangements, the Tenderer must provide evidence that it meets or exceeds the sum of all the individual requirements for the lots being tendered in regard to:
- a) Average annual turnover;
 - b) Particular experience including key production rates;
 - c) Financial means, etc;
 - d) Personnel capabilities; and
 - e) Equipment capabilities.
- 14.2** In case the Tenderer fail to fully meet any of these criteria, it may be qualified only for those lots for which the Tenderer meets the above requirement.
- 15. Form of Tender**
- 15.1** The Tenderer shall fill the Form of Tender furnished in the Tendering Documents. The Form of Tender must be completed without any alterations to its format and no substitute shall be accepted.
- 16. Tender Prices**
- 16.1** The Contract shall be for the whole Works, as described in sub-Clause 1.1, based on the priced Bill of Quantities

submitted by the Tenderer.

16.2 The Tenderer shall fill in rates and prices for all items of the Works described in the **Bill of Quantities**. Items for which no rate or price is entered by the Tenderer will not be paid for by the Procuring Entity when executed and shall be deemed to be covered by the other rates and prices in the **Bill of quantities**.

16.3 All duties, taxes and other levies payable by the Contractor under the Contract, or for any other cause, as of the date 15 days prior to the deadline for submission of Tenders, shall be included in the rates, prices and total Tender price submitted by the Tenderer.

16.4 The rates and prices quoted by the Tenderer shall be subject to adjustment during the performance of the Contract if provided for in the **Tender Data Sheet** and the provisions of the Conditions of Contract. The Tenderer shall submit with the Tender all the information required under the **Contract Data Sheet**.

17. Tender Currencies

17.1 The unit rates and prices shall be quoted by the Tenderer in the currency as specified in the **Tender Data Sheet**.

17.2 Tenderers shall indicate details of their expected foreign currency requirements in the Tender, if any. The rates of exchange to be used by the Tenderers in arriving at the local currency equivalent shall be the selling rates for similar transactions established by the authority specified in the **Tender Data Sheet** prevailing on the date 28 days prior to the latest deadline for submission of Tenders. These exchange rates shall apply for all payments so that no exchange risk will be borne by the Tenderer. In any case, payments will be computed using the rates quoted in the Tender.

17.3 Tenderers may be required by the Procuring Entity to clarify their foreign currency requirements and to substantiate that the amounts included in the rates and prices and in the Contract Data Sheet are reasonable and responsive to sub-Clause 17.1.

18. Tender Validity Period

18.1 Tenders shall remain valid for the period specified in the **Tender Data Sheet** after the Tender submission deadline prescribed by the Procuring Entity, pursuant to ITT Clause 22. A Tender valid for a shorter period shall be rejected by the Procuring Entity as non responsive.

18.2 In exceptional circumstances, prior to expiry of the original Tender validity period, the Procuring Entity may request that the Tenderers extend the period of validity for a specified

additional period. The request and the Tenderers' responses shall be made in writing or by cable. A Tenderer may refuse the request without forfeiting its Tender Security or causing to be executed its Tender Securing declaration. A Tenderer agreeing to the request will not be required or permitted to otherwise modify the Tender, but will be required to extend the validity of its Tender Security or Tender Securing declaration for the period of the extension, and in compliance with ITT Clause 19 in all respects.

18.3 In the case of fixed price contracts, if the award is delayed by a period exceeding sixty (60) days beyond the expiry of the initial Tender validity period, the contract price will be increased by a factor specified in the request for extension. The Tender evaluation shall be based on the Tender price without taking into consideration on the above correction.

19. Tender Security and Tender Securing Declaration

19.1 Pursuant to ITT Clause 12, where required in the **Tender Data Sheet**, the Tenderer shall furnish as part of its Tender, a Tender Security in original form and in the amount and currency specified in the **Tender Data Sheet**. A Tender Securing Declaration as specified in the **Tender Data Sheet** in the format provided in section X shall be provided as a mandatory requirement.

19.2 The Tender Security or Tender Securing Declaration is required to protect the Procuring Entity against the risk of Tenderer's conduct which would warrant the security's forfeiture, pursuant to ITT sub-Clause 19.9.

19.3 The Tender Security shall be denominated in the currency of the Tender and shall be in one of the following forms:

- a) A Bank Guarantee;
- b) An Insurance Bond issued by an insurance firm approved by the PPOA located in Kenya
- c) An irrevocable letter of credit issued by a reputable bank.

19.4 The Tender Security shall be in accordance with the Form of the Tender Security included in Section X or another form approved by the Procuring Entity prior to the Tender submission.

19.5 The Tender Security shall be payable promptly upon written demand by the Procuring Entity in case any of the conditions listed in sub-Clause 19.8 are invoked.

19.6 Any Tender not accompanied by a Tender Security in

accordance with sub-Clauses 19.1 or 19.3 shall be rejected by the Procuring Entity as non-responsive, pursuant to ITT Clause 28.

- 19.7** The Procuring Entity shall immediately release any Tender Security if:
- a) The procuring proceedings are terminated;
 - b) The Procuring Entity determines that none of the submitted Tenders is responsive;
 - c) A contract for the procurement is entered into.
- 19.8** The Tender Security shall be forfeited and the Tender Securing Declaration executed if the Tenderer:
- a) Withdraws its Tender after the deadline for submitting Tenders but before the expiry of the period during which Tenders must remain valid;
 - b) Rejects a correction of an arithmetic error pursuant to sub-Clause 29.2;
 - c) Refuse to enter into a written contract in accordance with ITT Clause 40;
 - d) Fails to furnish the Performance Security in accordance with ITT Clause 41.
- 19.9** The Tender Security and Tender Securing Declaration of a joint venture must be in the name of the joint venture submitting the Tender.
- 19.10** A Tenderer shall be suspended from being eligible for Tendering in any contract with the Procuring Entity for the period of time indicated in the Tender Securing Declaration:
- a) If the Tenderer withdraws its Tender, except as provided in ITT sub-Clauses 18.2 and 29.2; or
 - b) In the case of a successful Tenderer, if the Tenderer fails within the specified time limit to:
 - (i) Sign the contract; or
 - (ii) Furnish the required Performance Security.

**20. Format and
Signing of Tender**

- 20.1** The Tenderer shall prepare one original of the documents comprising the Tender as described in ITT Clause 12 of these Instructions to Tenderers, with the Form of Tender, and clearly marked “**ORIGINAL**”. In addition, the Tenderer shall submit copies of the Tender, in the number specified in the **Tender Data Sheet**, and clearly marked as “**COPIES**”. In the event of discrepancy between them, the original shall prevail.
- 20.2** The original and all copies of the Tenders shall be typed or written in indelible ink and shall be signed by a person or persons duly authorized to sign on behalf of the Tenderer. This authorization shall consist of a written confirmation as specified in the **Tender Data Sheet** and shall be attached to the Tender. The name and position held by each person signing the authorization must be typed or printed below the signature. All pages of the Tender, except for un-amended printed literature, shall be initialled by the person or persons signing the Tender.
- 20.3** Any interlineations, erasures, or overwriting shall be valid only if they are initialled by the person or persons signing the Tender.
- 20.4** The Tenderer shall furnish information as described in the Form of Tender on commissions or gratuities, if any, paid or to be paid to agents relating to this Tender and to contract execution if the Tenderer is awarded the contract

D. Submission of Tenders

**21. Sealing and
Marking of
Tenders**

- 21.1** The Tenderer shall seal the original and each copy of the Tender in separate envelopes, duly marking the envelopes as “**ORIGINAL**” and “**COPY**”. The envelopes shall then be sealed in an outer envelope securely sealed in such a manner that opening and resealing cannot be achieved undetected.
- 21.2** The inner and outer envelopes shall:
- a) Be addressed to the Procuring Entity at the address given in the **Tender Data Sheet**; and
 - b) Bear the Project name indicated in the **Tender Data Sheet**, the Invitation for Tenders (IFB) title and number indicated in the **Tender Data Sheet**, and a statement: “**DO NOT OPEN BEFORE,**” to be completed with the time and the date specified in the **Tender Data Sheet**, pursuant to ITT sub-

Clause 22.1.

21.3 In addition to the identification required in sub-Clause 21.2, the inner envelopes shall also indicate the name and address of the Tenderer to enable the Tender be returned unopened in case it is declared late, pursuant to sub-Clause 22.1 and for matching purpose under ITT Clause 23

21.4 If the outer envelope is not sealed and marked as required by ITT sub clause 21.2, the Procuring Entity shall assume no responsibility for misplacement or premature opening of the Tender.

22. Deadline for Submission of Tenders

22.1 Tenders shall be received by the Procuring Entity at the address specified under ITT sub-Clause 21.2 no later than the date and time specified in the **Tender Data Sheet**.

22.2 The Procuring Entity may, in exceptional circumstances and at its discretion, extend the deadline for the submission of Tenders by amending the Tendering documents in accordance with ITT Clause 9, in which case all rights and obligations of the Procuring Entity and Tenderers previously subject to the deadline will thereafter be subject to the new deadline.

22.3 The extension of the deadline for submission of Tenders shall not be made later than the period specified in the **Tender Data Sheet** before the expiry of the original deadline.

23. Late Tenders

23.1 The Procuring Entity shall not consider for evaluation any Tender that arrives after the deadline for submission of Tenders, in accordance with ITT Clause 22.

23.2 Any Tender received by the Procuring Entity after the deadline for submission of Tenders shall be declared late, rejected and returned unopened to the Tenderer

24. Modification, Substitution and Withdrawal of Tenders

24.1 A Tenderer may modify or substitute or withdraw its Tender after it has been submitted, provided that written notice of the modification, including substitution or withdrawal of the Tender, is received by the Procuring Entity prior to the deadline prescribed for submission of Tenders prescribed under ITT sub-Clause 22.1.

- 24.2** The Tenderer’s modification or substitution or withdrawal notice shall be prepared, sealed, marked, and dispatched in accordance with the provisions of ITT Clauses 20 and 21 with the outer and inner envelopes additionally marked “**MODIFICATION**” or **SUBSTITUTION** or “**WITHDRAWAL**” as appropriate. The notice may also be sent by electronic mail and facsimile, but followed by a signed confirmation copy, postmarked not later than the deadline for submission of Tenders.
- 24.3** No Tender may be withdrawn, replaced or modified in the interval between the deadline for submission of Tenders and the expiration of the period of Tender validity specified by the Tenderer on the Tender Form. Withdrawal of a Tender during this interval shall result in the Tenderer’s forfeiture of its Tender Security or execution of Tender Securing Declaration, pursuant to the ITT sub-Clause 19.9.
- 24.4** Withdrawal of a Tender between the deadline for submission of Tenders and the expiration of the period of Tender validity specified in the **Tender Data Sheet** or as extended pursuant to sub-Clause 22.2 shall result in the forfeiture of the Tender Security and execution of Tender Securing Declaration pursuant to ITT sub-Clause 19.9.
- 24.5** Tenderers may only offer discounts to, or otherwise modify the prices of their Tenders by submitting Tender modifications in accordance with this Clause, or included in the original Tender submission.

E. Opening and Evaluation of Tenders

25. Opening of Tenders

- 25.1** The Procuring Entity will open all Tenders including modifications, substitution or withdraw notices made pursuant to ITT Clause 24, in public, in the presence of Tenderers or their representatives who choose to attend and other parties with legitimate interest and Tender proceedings, at the place on the date and at time specified in the **Tender Data Sheet**. The Tenderers’ representatives who are present shall sign a register as proof of their attendance.
- 25.2** Envelopes marked “**WITHDRAWAL**” shall be opened and read out first. Tenders for which an acceptable notice of withdrawal has been submitted

pursuant to ITT Clause 24 shall not be opened but returned to the Tenderer. If the withdrawal envelope does not contain a copy of the "Power of Attorney" confirming the signature as a person duly authorized to sign on behalf of the Tenderer, the corresponding Tender will be opened. Subsequently, all envelopes marked "**MODIFICATION**" shall be opened and the submissions therein read out in appropriate detail. Thereafter all envelopes marked or "**SUBSTITUTION**" opened and the submissions therein read out in appropriate detail.

- 25.3** All other envelopes shall be opened one at a time. The Tenderers' names, the Tender prices, the total amount of each Tender and of any alternative Tender (if alternatives have been requested or permitted), any discounts, the presence or absence of Tender security, and such other details as the appropriate tender opening committee may consider appropriate, will be announced by the Secretary of the Tender Opening Committee at the opening.
- 25.4** Tenders or modifications that are not opened and not read out at Tender opening shall not be considered further for evaluation, irrespective of the circumstances. In particular, any discount offered by a Tenderer which is not read out at Tender opening shall not be considered further.
- 25.5** Tenderers are advised to send in a representative with the knowledge of the content of the Tender who shall verify the information read out from the submitted documents. Failure to send a representative or to point out any un-read information by the sent Tenderer's representative shall indemnify the Procuring Entity against any claim or failure to read out the correct information contained in the Tenderer's Tender.
- 25.6** No Tender will be rejected at Tender opening except for late Tenders which will be returned unopened to the Tenderer, pursuant to ITT Clause 23.
- 25.7** The Secretary of the appropriate tender opening committee shall prepare minutes of the Tender opening. The record of the Tender opening shall include, as a minimum: the name of the Tenderers and whether or not there is a withdrawal, substitution or modification, the Tender price per Lot if

applicable, including any discounts and alternative offers and the presence or absence of a Tender Security or Tender Securing Declaration.

25.8 The Tenderers' representatives who are present shall be requested to sign the record. The omission of a Tenderer's signature on the record shall not invalidate the contents and affect the record.

25.9 A copy of the minutes of the Tender opening shall be furnished to individual Tenderers upon request.

26. Confidentiality

26.1 Information relating to the examination, clarification, evaluation, and comparison of Tenders and recommendations for the award of a Contract shall not be disclosed to Tenderers or any other persons not officially concerned with such process until the award to the successful Tenderer has been announced.

26.2 Any effort by a Tenderer to influence the Procuring Entity's processing of Tenders or award decisions may result in the rejection of his Tender.

26.3 Notwithstanding sub-Clause 26.2, from the time of Tender opening to the time of Contract award, if any Tenderer wishes to contact the Procuring Entity on any matter related to the Tendering process, it should do so in writing.

27. Clarification of Tenders

27.1 To assist in the examination, evaluation, comparison of Tenders and post-qualification of the Tenderer, the Procuring Entity may, at its discretion, ask a Tenderer for clarification of its Tender including breakdown of prices. Any clarification submitted by a Tenderer that is not in response to a request by the Procuring Entity shall not be considered.

27.2 The request for clarification and the response shall be in writing. No change in the prices or substance of the Tender shall be sought, offered, or permitted except to confirm the correction of arithmetic errors discovered by the Procuring Entity in the evaluation of Tenders in accordance with ITT Clause 29.

27.3 From the time of Tender opening to the time of Contract award if any Tenderer wishes to contact the Procuring Entity on any matter related to the Tender it should do so in writing.

28. Preliminary Examination of Tenders

- 28.1** Prior to the detailed evaluation of Tenders, the Procuring Entity will determine whether:
- a) The Tender has been submitted in the required format;
 - b) Any Tender Security submitted is in the required form, amount and validity period;
 - c) The Tender has been signed by the person lawfully authorized to do so;
 - d) The required number of copies of the Tender have been submitted;
 - e) The Tender is valid for the period required;
 - f) All required documents and information have been submitted; and
 - g) Any required samples have been submitted.
- 28.2** The Procuring Entity will confirm that the documents and information specified under ITT Clause 12 and ITT Clause 13 have been provided in the Tender. If any of these documents or information is missing, or is not provided in accordance with the Instructions to Tenderers, the Tender shall be rejected.
- 28.3** The Procuring Entity may waive any minor informality, nonconformity, or irregularity in a Tender which does not constitute a material deviation, provided such waiver does not prejudice or affect the relative ranking of any Tenderer
- 28.4** A substantially responsive Tender is one which conforms to all the terms, conditions, and specifications of the Tendering documents, without material deviation or reservation. A material deviation or reservation is one that:
- a) Affects in any substantial way the scope, quality, or execution of the Works;
 - b) Limits in any substantial way, inconsistent with the Tendering documents, the Procuring Entity's rights or the Tenderer's obligations under the Contract; or

- c) If rectified, would affect unfairly the competitive position of other Tenderers presenting substantially responsive Tenders.

28.5 If a Tender is not substantially responsive, it will be rejected by the Procuring Entity, and may not subsequently be made responsive by correction or withdrawal of the non-conforming deviation or reservation.

29. Correction of Errors

29.1 Tenders determined to be substantially responsive will be checked by the Procuring Entity for any arithmetic errors. Errors will be corrected by the Procuring Entity as follows:

- a) If there is a discrepancy between unit prices and the total price that is obtained by multiplying the unit price and quantity, the unit price shall prevail, and the total price shall be corrected, unless in the opinion of the Procuring Entity there is an obvious misplacement of the decimal point in the unit price, in which the total price as quoted shall govern and the unit price shall be corrected;
- b) If there is an error in a total corresponding to the addition or subtraction of subtotals, the subtotals shall prevail and the total shall be corrected; and
- c) Where there is a discrepancy between the amounts in figures and in words, the amount in words will govern.

29.2 The amount stated in the Tender will, be adjusted by the Procuring Entity in accordance with the above procedure for the correction of errors and, with, the concurrence of the Tenderer, shall be considered as binding upon the Tenderer. If the Tenderer does not accept the corrected amount, its Tender will then be rejected, and the Tender Security may be forfeited and the Tender Securing Declaration may be executed in accordance with sub-Clause 19.9.

30. Conversion to Single Currency

30.1 To facilitate the evaluation and comparison, the Procuring Entity will convert all Tender prices expressed in the amounts in various currencies in which the Tender prices are payable to Kenya Shillings at the selling exchange rate established for similar transactions by the Central Bank of Kenya ruling on the date specified in the **Tender Data**

Sheet.**31. Comparison of Tenders**

- 31.1** The Procuring Entity shall evaluate and compare only the Tenders determined to be substantially responsive in accordance with ITT Clause 28.
- 31.2** In evaluating the Tenders, the Procuring Entity will determine for each Tender the evaluated Tender price by adjusting the Tender price as follows:
 Making any correction for errors pursuant to ITT Clause 29;
 Excluding provisional sums and the provision, if any for contingencies in the Bill of Quantities, but including Day work, where priced competitively; and
 Making appropriate adjustments to reflect discounts or other price modifications offered in accordance with sub-Clause 24.5.
- 31.3** The Procuring Entity may waive any minor informality or non-conformity, which does not constitute a material deviation, provided such waiver does not prejudice or affect the relative standing of any Tenderer. Variations, deviations, and alternative offers and other factors, which are in excess of the requirements of the Tendering documents or otherwise result in unsolicited benefits for the Procuring Entity will not be taken into account in Tender evaluation.

32. National Preference

- 32.1** In the evaluation of Tenders, the Procuring Entity shall apply exclusive preference to citizens of Kenya where:
- a) The funding is 100% from the Government of Kenya or a Kenyan body;
 - b) The amounts are below the prescribed threshold of KShs.200 million;
- 32.2** To qualify for the preference, the candidate shall provide evidence of eligibility by:
- a) Proving Kenyan citizenship by production of a Kenyan Identity Card; or
 - b) Providing proof of being a “citizen contractor” in terms of section 3(1) of the Act, i.e. being a natural person or an incorporated company wholly owned and controlled by persons who are citizens of

Kenya.

- 32.3** The Minister of Finance may prescribe additional preference and/or reservation schemes, for example for procurements above these thresholds. If such additional preference schemes apply, details will be given in the **Tender Data Sheet**.
- 33. Determination of the Lowest Evaluated Tender** **33.1** The Tender with the lowest evaluated price from among those which are eligible, compliant and substantially responsive shall be the lowest evaluated Tender.
- 34. Post-qualification of Tenderer** **34.1** If specified in the **Tender Data Sheet**, post-qualification shall be undertaken.
- 34.2** The Procuring Entity will determine to its satisfaction whether the Tenderer that is selected as having submitted the lowest evaluated responsive Tender is qualified to perform the contract satisfactorily, in accordance with the criteria listed in sub-Clause 13.3.
- 34.3** The determination will take into account the Tenderer's financial, technical, and production capabilities. It will be based upon an examination of the documentary evidence of the Tenderer's qualifications submitted by the Tenderer, pursuant to sub-Clause 13.3, as well as such other information as the Procuring Entity deems necessary and appropriate. Factors not included in these Tendering documents shall not be used in the evaluation of the Tenderer's qualifications.
- 34.4** An affirmative determination will be a prerequisite for award of the contract to the Tenderer. A negative determination will result in rejection of the Tenderer's Tender, in which event the Procuring Entity will proceed to the next lowest evaluated Tender to make a similar determination of that Tenderer's capabilities to perform satisfactorily.

F. Award of Contract

- 35. Criteria of Award** **35.1** Subject to ITT Clause 35 and 36, the Procuring Entity will award the Contract to the Tenderer whose Tender has been determined to be substantially responsive to the Tendering documents and who has offered the lowest Evaluated Tender Price, provided that such

Tenderer has been determined to be:

- a) Eligible in accordance with the provisions of ITT Clause 3;
- b) Is determined to be qualified to perform the Contract satisfactorily;
- c) Successful negotiations have been concluded.

35.2 If, pursuant to sub-Clause 14.1, this Contract is being awarded on a “lot and package” basis, the lowest evaluated Tender price will be determined when evaluating this Contract in conjunction with other Contracts to be awarded concurrently, taking into account any discounts offered by the Tenderer for award of more than one Contract.

36. Clarifications

36.1 Clarifications may be undertaken with the lowest evaluated Tenderer relating to the following areas:

- a) A minor alteration to the technical details of the statement of requirements;
- b) Reduction of quantities for budgetary reasons, where the reduction is in excess of any provided for in the Tendering documents;
- c) A minor amendment to the Contract Data Sheet;
- d) Finalizing payment arrangements;
- e) Mobilization arrangements;
- f) Agreeing final delivery or work schedule to accommodate any changes required by the Procuring Entity;
- g) The methodology or staffing; or
- h) Clarifying details that were not apparent or could not be finalized at the time of Tendering.

- 36.2** Clarifications shall not change the substance of the tender.
- 37. Procuring Entity's Right to accept any tender and to reject any or all Tenders**
- 37.1** Notwithstanding ITT Clause 35, the Procuring Entity reserves the right to accept or reject any Tender, and to cancel the Tendering process and reject all Tenders, at any time prior to the award of Contract, without thereby incurring any liability to the affected Tenderer or Tenderers.
- 37.2** Notice of the rejection of all Tenders shall be given promptly within 14 days to all Contractors that have submitted Tenders.
- 37.3** The Procuring Entity shall upon request communicate to any Tenderer the grounds for its rejection of its Tenders, but is not required to justify those grounds.
- 38. Procuring Entities Right to Vary Quantities at the Time of Award**
- 38.1** The Procuring Entity reserves the right at the time of contract award to increase or decrease the quantity of goods or related services originally specified in these Tendering documents (schedule of requirements) provided this does not exceed by the percentage indicated in the **Tender Data Sheet**, without any change in unit price or other terms and conditions of the Tender and Tendering documents.
- 39. Notification of Award**
- 39.1** The Tenderer whose Tender has been accepted will be notified of the award by the Procuring Entity prior to expiration of the Tender validity period by e-mail or facsimile confirmed by registered letter. This letter (hereinafter and in the Conditions of Contract called the "Letter of Acceptance") will state the sum that the Procuring Entity will pay the Contractor in consideration of the provision and maintenance of the Work(s) as prescribed by the Contract (hereinafter and in the Contract called the "Contract Price").
- 39.2** The notification of award will constitute the formation of the Contract, subject to the Tenderer furnishing the Performance Security in accordance with ITT Clause 41 and signing the Contract in accordance with sub-Clause

40.2

39.3 At the same time as the person submitting the successful Tender is notified, the Procuring Entity will notify each unsuccessful Tenderer, the name of the successful Tenderer and the Contract amount and will discharge the Tender Security and Tender Securing Declaration of the Tenderer pursuant to ITT sub Clause 19.7.

39.4 If, after notification of award, a Tenderer wishes to ascertain the grounds on which its Tender or application for pre-qualification was unsuccessful, it should address its request to the secretary of the Tender Committee that authorized the award of contract. The secretary of the Tender Committee shall, within fourteen days after a request, provide written reasons as to why the Tender, proposal or application to be pre-qualified was unsuccessful. However, failure to take this opportunity to clarify the grounds for rejection does not affect the Tenderer's right to seek immediate review by the Public Procurement Administrative Review Board under Clause 45.

40. Signing of Contract

40.1 Promptly, and in no case later than 14 days, after notification, Procuring Entity shall send the successful Tenderer the Agreement and Contract Data Sheet, incorporating all agreements between the parties obtained as a result of Contract negotiations.

40.2 Within the period specified in the notification or Tender Data Sheet but not earlier than fourteen (14) days since notification of award of contract, the successful Tenderer shall sign and date the contract and return it to the Procuring Entity.

41. Performance Security

41.1 Within thirty (30) days but after 14 days after receipt of the Letter of Acceptance, the successful Tenderer shall deliver to the Procuring Entity a Performance Security in the amount and in the form stipulated in the Tender Data Sheet and the Contract Data Sheet, denominated in the type and proportions of currencies in the Letter of Acceptance and

in accordance with the Conditions of Contract.

41.2 If the Performance Security is provided by the successful Tenderer in the form of a Bank Guarantee or Insurance Bond, it shall be issued either:

- a) At the Tenderer's option, by a bank or insurance firm located in Kenya, or a foreign bank or insurance firm through a correspondent bank or insurance firm located in Kenya;
- b) With the consent of the Procuring entity, directly by a foreign bank acceptable to the Procuring entity.

41.3 Failure of the successful Tenderer to comply with the requirement of sub-Clause 41.1 shall constitute sufficient grounds for the annulment of the award and forfeiture of the Tender Security, in which event the Procuring Entity may make the award to the next lowest evaluated Tenderer or call for new Tenders.

42. Advance Payment

42.1 The Procuring Entity will provide an Advance Payment as stipulated in the Conditions of Contract, subject to a maximum amount, as stated in the Tender Data Sheet.

42.2 The Advance Payment request shall be accompanied by an Advance Payment Security (Guarantee) in the form provided in Section X. For the purpose of receiving the Advance Payment, the Tenderer shall make an estimate of, and include in its Tender, the expenses that will be incurred in order to commence work. These expenses will relate to the purchase of equipment, machinery, materials, and on the engagement of labour during the first month beginning with the date of the Procuring Entity's "Notice to Commence" as specified in the Contract Data Sheet.

43. Adjudicator

43.1 The Procuring Entity proposes the person named in the Tender Data Sheet to be appointed as Adjudicator under the Contract, at an hourly fee specified in the Tender Data Sheet, plus reimbursable expenses. If the

Tenderer disagrees with this proposal, the Tenderer should so state in the Tender. If, in the Letter of Acceptance, the Procuring Entity has not agreed on the appointment of the Adjudicator, the Adjudicator shall be appointed by the Appointing Authority designated in the Contract Data Sheet at the request of either party.

G. Review of Procurement Decisions

- 44. Right to Review** **44.1** A Tenderer who claims to have suffered or risk suffering, loss or damage or injury as a result of breach of a duty imposed on a Procuring Entity or an Approving Authority by the Public Procurement and Disposal Act, 2005 and the Public Procurement and Disposal Regulations 2006, the procurement proceedings or processes, may seek administrative review as prescribed by the Act. The following matters, however, shall not be subject to the administrative review:
- a) The choice of procurement method;
 - b) a decision by the Procuring Entity to reject all Tenders, proposals or quotations;
 - c) Where a contract is signed in accordance to Section 68 of the Public Procurement and Disposal Act,2005;
 - d) Where an appeal is frivolous.
- 45. Time Limit on Review** **45.1** The Tenderer shall submit an application for review in the number of copies and pay fees as prescribed by the Public Procurement and Disposal Regulations 2006 within fourteen (14) days of the time the Tenderer became or should have become aware of the circumstances giving rise to the complaint or dispute.
- 46. Submission of Applications for Review by the Public Procurement Administrative Review Board** **46.1** Any application for administrative review shall be submitted in writing to the Secretary, Public Procurement Administrative Review Board on Form RB 1 at the address shown in the Tender Data Sheet. The secretary to the review board shall immediately after filing of the request, serve a copy thereof on the Procuring Entity or Director-General

as the case may be.

46.2 The application for administrative review shall be in accordance with the requirements of Regulation 73 of the Public Procurement and Disposals Regulations, 2006, including:

- a) Reasons for the complaint, including any alleged breach of the Act or Regulations;
- b) An explanation of how the provisions of the Act and or Regulation has been breached or omitted, including the dates and name of the responsible public officer, where known;
- c) Statements or other evidence supporting the complaint where available as the applicant considers necessary in support of its request;
- d) Remedies sought;
- e) Any other information relevant to the complaint.

**47. Decision by the
Public Procurement
Administrative
Review Board**

47.1 The Administrative Review Board shall within thirty days after receipt of an application for administrative review deliver a written decision which shall indicate:

- a) Annuling anything the Procuring Entity has done in the procurement proceedings, including annulling the procurement proceedings in their entirety;
- b) Giving directions to the Procuring Entity with respect to anything to be done or redone in the procurement proceedings;
- c) Substituting the decision of the Review Board for any decision of the Procuring Entity in the procurement proceedings;
- d) Order the payment of costs as between parties to the review.

47.2 The decision made by the Review Board shall, be final and binding on the parties unless judicial review thereof commences within fourteen (14) days from the date of the Review Board's decision.

48. Appeal on the

48.1 Any party to the review aggrieved by the decision

**decision of the
Review Board**

of the Review Board may appeal to the High Court
and the decision of the High Court shall be final.

SECTION III: TENDER DATA SHEET

Tender Data Sheet (TDS)

Instructions to Tenderers Clause Reference

TDS Reference Number	ITT Clause Number	Amendments of, and Supplements to, Clauses in the Instruction to Tenderers
A. Introduction		
1.	1.1	The Procuring Entity is ISIOLO COUNTY GOVERNMENT
2.	1.1	Name of Project is “Construction/Augmentation of Modogashe Water Supply Project
3.	1.2	The expected completion date of the works is 4 months after signing the contract
4.	1.3	The Objectives of the Project is to <i>increase access to portable domestic water to the residence of Modogashe in Isiolo County</i>
5.	2.1	Name of financing institution is County Government of Isiolo Name of the Procuring entity is County Governmnt of Isiolo Financial Year is 2024/2025 Describe works under the contracts The works involves but is not limited to the following: - <ul style="list-style-type: none"> h) Drilling and Equipping 1No Borehole i) Rehabilitation and equipping of 2No. Infiltration gallery j) Construction of Generator house k) Piping -HDPE PN12.5 - Rising Main -1.2Km and 3Km distribution line l) Construction of 15m high 100m³ Elevated Steel Tank m) Fencing n) Construction of 2No. Water Kiosks a)
6.	2.2	The loan/ credit number is N/A.
7.	5.1	Alternative Tenders are <i>Not Allowed</i>
8.	5.2	Alternative time for completion Not applicable
9.	3.1	Tenderers open to all Kenyan Citizen Registered under NCA 6 - Water works and above
10.	7.3	N/A
11.	7.5	N/A

	7.6	N/A

B. Tendering Documents		
12.	8.2	The number of copies to be completed and returned with the Tender is Two.
13.	8.1	Address for clarification of Tendering Document is HEAD OF PROCUREMENT ISIOLO COUNTY GOVERNMENT P.O. Box 36-60300 <u>ISIOLO</u>
14.	8.2	Period to Respond to request for clarification by the Procuring Entity <i>7 days</i> Period Prior to deadline for submission of Tenders for Tenderers to request clarification <i>7 days</i>

C. Preparation of Tenders																				
15.	11.1	Language of Tender and all correspondence shall be English																		
16.	13.3	<p>Other information or materials required to be completed and submitted by Tenderers and of which will form the</p> <p>EVALUATION CRITERIA</p> <p>The following requirements must be met by the tenderer notwithstanding other requirements in the tender documents, bidder Must serialize all the pages of each bid submitted</p> <p>Mandatory Requirements (MR)</p> <table border="1" style="width: 100%; border-collapse: collapse;"> <thead> <tr> <th style="width: 10%;">No.</th> <th style="width: 60%;">Requirement</th> <th style="width: 30%;">Responsive or Non Responsive</th> </tr> </thead> <tbody> <tr> <td style="text-align: center;">MR 1</td> <td>Must submit a copy of certificate of registration/Incorporation</td> <td></td> </tr> <tr> <td style="text-align: center;">MR 2</td> <td>Must submit a copy of valid tax compliance Certificate</td> <td></td> </tr> <tr> <td style="text-align: center;">MR 3</td> <td>Must fill the bill of quantities in the format provided(partially filled Boq will be rejected)</td> <td></td> </tr> <tr> <td style="text-align: center;">MR 4</td> <td>Must fill the form of tender in the format provided and signed by the authorized person as per CR12</td> <td></td> </tr> <tr> <td style="text-align: center;">MR 5</td> <td>Must provide Tender Security of Kshs 300,000 in form of bank guarantee only valid</td> <td></td> </tr> </tbody> </table>	No.	Requirement	Responsive or Non Responsive	MR 1	Must submit a copy of certificate of registration/Incorporation		MR 2	Must submit a copy of valid tax compliance Certificate		MR 3	Must fill the bill of quantities in the format provided(partially filled Boq will be rejected)		MR 4	Must fill the form of tender in the format provided and signed by the authorized person as per CR12		MR 5	Must provide Tender Security of Kshs 300,000 in form of bank guarantee only valid	
No.	Requirement	Responsive or Non Responsive																		
MR 1	Must submit a copy of certificate of registration/Incorporation																			
MR 2	Must submit a copy of valid tax compliance Certificate																			
MR 3	Must fill the bill of quantities in the format provided(partially filled Boq will be rejected)																			
MR 4	Must fill the form of tender in the format provided and signed by the authorized person as per CR12																			
MR 5	Must provide Tender Security of Kshs 300,000 in form of bank guarantee only valid																			

	for 150 day from the date of opening.	
MR 6	Power of attorney <i>proof</i> authorizing the signatory of the tender to commit the tenderer if not the director of the firm. Must fill business questioner.	
MR 7	Must be registered with valid NCA6 water work and above	
MR 8	Must be registered with valid annual practicing NCA6 water work and above	
MR 9	Valid business permit certificate	

At this stage, the tenderer’s submission will either be responsive in the entire mandatory requirement (MR) above or non – responsive. The non-responsive submission will be eliminated from the entire evaluation process and will not be considered further.

Technical Evaluation.

No.	PARAMETER	MAXIMUM SCORE
1	Relevant Experience	
	Experience as prime contractor in the construction of at least two complete projects of a similar nature and complexity equivalent to the Works as described.	20
	General Experience Experience in other construction works for the last three years	10
2	Equipment’s	
	a) Drilling Rig	Owned(Max 24 marks) 0 - 24
	b) Compressor	
	c) Test Pumping Unit (TPU)	50% owned 50% leased (Max 18marks) 0 - 18
	d) Concrete Mixer	
	e) Pick up	
	f) Water Bowser 12000ltrs	100% leased(Max 12 marks) 0 - 12
	Proof of ownership and lease must be provided i.e. logbooks	
3	Key Personnel	
	Site Agent Max (3marks)	Qualification – Degree 5
		HND 3
		Diploma 2
	Qualification – Civil/Water Engineering with a total work experience of 8 years	

SPECIFICATIONS

			General Foreman (Max. 3Marks)	Qualification water engineering or equivalent with a total work experience of 8 years	Diploma	3
			Electrician (5 marks)	Qualification Licensed Min.Class C with 5 years working experience	Diploma	3
					Certificate	2

SPECIFICATIONS

			Plumber	Qualification - Plumbing Course with a total work experience of 5 years		4	
			Power Plant Mechanic	Qualification plant mechanic course with a total of 5 years working experience	Certificate	5	
			Steel fixer	Qualification	Certificate	2	
			Driver	Qualification	Driving licence	2	
		4	Financial Capacity				
			Audited Accounts- financial capability of the firm based on information provided in the last 3 years audited account (2022 – 2025)			2	
			Line of credit of over 50 million			4	
			Annual volume (turn over) of construction work for the successful Tenderer in any of the last 3 years shall be: over Kshs 100 million.			4	
			Bank statements (last six months to date of tender)			2	
			Proposed Programme(Work methodology and schedule)			10	
			Total			100%	
		<p>Only bidders who score 70% and above will be subject to financial evaluation. Those who score below 70% will be eliminated at this stage from the entire evaluation process and will not be considered further</p> <p>The authority will verify information submitted. Any form of forgery or misinformation will lead to cancellation of the bid</p> <p>If a bidder applies for more than one tender the aggregate capacity to undertake the works will be taken in to consideration during evaluation</p>					
17.	13.4	<p>In the case of joint venture each partner shall submit information required under Clause ITT Clause 13.4. In addition, the Tenderer shall furnish the following,</p> <p style="margin-left: 40px;">a) The Power of the attorney.....</p> <p style="margin-left: 40px;">b) Audited books of account with a turnover of at least Kshs 100 Million for the last two years.</p>					
18.	16.4	<p>The price shall be <i>fixed</i></p> <p>Information to be submitted with the Tender are:</p> <p style="margin-left: 40px;">i) The basic rates of materials and services</p>					

SPECIFICATIONS

19.	17.1	The currency in which the prices shall be quoted shall be: <i>Kenyan Shilling</i>
20.	17.2 30.2	The authority for establishing the rates of exchange shall be N/A. The applicable date for exchange rates for tendering and evaluation purposes N/A
21.	18.1	The Tender validity period shall be 120 days.

SPECIFICATIONS

22.	19.1	The amount of Tender Security Kshs.300,000.00 bank guarantee valid for 150 day from the date of opening
23.	20.1	In addition to the original of the Tender, the Tenderer should submit 2 copies of the Tender – 1 original + 1 copy
24.	20.2	Written confirmation of authorization are <i>Power of attorney – copies of original documents to be provided as proof authorizing the signatory of the tender to commit the tenderer.</i> <i>The form of tender must be fully filled and signed by the authorized person</i>

D. Submission of Tenders

25.	21.2 a)	Tenders shall be submitted to HEAD OF PROCUREMENT ISIOLO COUNTY GOVERNMENT P.O. Box 36-60300 <u>ISIOLO</u>
26.	21.2 b)	Project Name: Construction/Augmentation of Modogashe Water Supply Project Tender number... ICG/WATER/001W/2024-2025
27.	22.1	The deadline for Tender submission is a) Day b) Date...16th May 2025 c) Time ...11.00 A.M
28.	22.3	The extension of the deadline for submission of Tenders shall be made not later than 7 days
29	24.4	Expiry of Tender validity is 120 days

E. Opening and Evaluation of Tenders

29.	25.1	The Tender opening shall take place at: HEAD OF PROCUREMENT ISIOLO COUNTY GOVERNMENT P.O. Box 36-60300 <u>ISIOLO</u> Date...16 th May 2025 Time 11.30 am
30.	32.3	Additional Preference <i>Not applicable</i>
31.	34.1	Post- qualification will be undertaken
32.	38.1	Percentage for quantities increase or decrease is 15%

F. Award of Contract		
33.	41.1	The amount of Performance Security shall be <i>1% of the contract price</i>
34.	42.1	The Advance Payment shall be ... 20% of Contract price
35.	43.1	The proposed adjudicator for the project is: The Institution of Engineers of Kenya... <i>The hourly rate shall be determined by the Institution</i>
G. Review of Procurement Decisions		
37.	46.1	The address for submitting appeals to Administrative Review Board: The Secretary, Public Procurement Administrative Review Board, The Public Procurement Oversight Authority, 10 th Floor, National Bank House, P.O. Box 58583-00200, NAIROBI, Kenya. Tel : +254 (0) 20 3244000

SECTION IV: GENERAL CONDITIONS OF CONTRACT

Table of Clauses

A. General.....		48
1. Definitions.....		48
2. Interpretation... ..		50
3. Language, Law, Fraud and Corruption... ..		51
4. Confidentiality... ..		53
5. Contract Administrator’s decisions... ..		53
6. Delegation... ..		53
7. Communications... ..		53
8. Subcontracting... ..		53
9. Other Contractors... ..		53
10. Personnel... ..		53
11. Procuring Entity’s and Contractor’s Risks		54
12. Procuring Entity’s Risks		54
13. Contractor’s Risks... ..		55
14. Insurance.....		55
15. Site Investigation Reports... ..		55
16. Queries about the Contract Data Sheet.....		56
17. Contractor to Construct the Works.....		56
18. Commence-ment and Completion... ..		56
19. Approval by the Contract Administrator.....		56
20. Protection of the Environment... ..		56
21. Labour Laws.....		56
22. Health and Safety... ..		57
23. Discoveries... ..		57
24. Possession of the Site		57
25. Access to the Site.....		57
26. Instructions, Inspections and Audits.....		57
27. Disputes.....		58
28. Procedure for Disputes.....		58
29. Replacement of Adjudicator.....		58
B. Time Control.....		59
30. Programme... ..		59
31. Extension of the Intended Completion Date... ..		59
32. Acceleration... ..		60
33. Warangara duoys Ordered by the Contract Administrator.....		60
34. Management Meetings.....		60
35. Early Warning... ..		60
C. Quality Control.....		61
36. Identifying Defects.....		61
37. Tests.....		61
38. Correction of Defects... ..		61
39. Uncorrected Defects... ..		61

D.	Cost Control.....	61
	40. Bill of Quantities... ..	61
	41. Changes in the Quantities... ..	62
	42. Variations... ..	62
	43. Payments for Variations... ..	62
	44. Cash Flow Forecasts.....	63
	45. Payment Certificates.....	63
	46. Payments... ..	63
	47. Compensation Events... ..	64
	48. Taxes.....	65
	49. Currencies... ..	66
	50. Price Adjustment... ..	66
	51. Retention... ..	68
	52. Liquidated Damages... ..	68
	53. Bonus... ..	69
	54. Advance Payment... ..	69
	55. Performance Securities... ..	70
	56. Dayworks... ..	
	57. Cost of Repairs... ..	70
E.	Finishing the Contract.....	70
	58. Completion Certificate.....	70
	59. Taking Over... ..	71
	60. Final Account... ..	71
	61. Operating and Maintenance Manuals... ..	71
	62. Termination... ..	71
	63. Payment upon Termination... ..	73
	64. Property... ..	73
	65. Release from Performance	73
	66. Suspension of Financing... ..	73

A. General

1. Definitions

1.1 Boldface type is used to identify defined terms.

The **Adjudicator** is the person appointed jointly by the Procuring Entity and the Contractor to resolve disputes in the first instance, as provided for in Clauses 27 and 28 hereunder.

Bill of Quantities means the priced and completed Bill of Quantities forming part of the Tender.

Compensation Events are those defined in Clause 47 hereunder.

The **Completion Date** is the date of completion of the Works as certified by the Contract Administrator, in accordance with Sub-Clause 58.1.

The **Contract** is the Contract between the Procuring Entity and the Contractor to execute, complete, and maintain the Works. It consists of the documents listed in Clause 2.3 below.

The **Contractor** is a person or corporate body whose Tender to carry out the Works has been accepted by the Procuring Entity.

The **Contractor's Tender** is the completed Tendering document submitted by the Contractor to the Procuring Entity.

The **Contract Price** is the price stated in the Letter of Acceptance and thereafter as adjusted in accordance with the provisions of the Contract.

Days are calendar days; months are calendar months.

Day Works are varied work inputs subject to payment on a time basis for the Contractor's employees and Equipment, in addition to payments for associated Materials and Plant.

A **Defect** is any part of the Works not completed in accordance with the Contract.

The **Defects Liability Certificate** is the certificate issued by the Contract Administrator upon correction of defects by the Contractor.

The **Defects Liability Period** is the period named in the **Contract Data Sheet** and calculated from the Completion Date.

Drawings include calculations and other information

provided or approved by the Contract Administrator for the execution of the Contract.

The **Procuring Entity** is the party who employs the Contractor to carry out the Works.

Equipment is the Contractor's machinery and vehicles brought temporarily to the Site to construct the Works.

The **Initial Contract Price** is the Contract Price listed in the Procuring Entity's Letter of Acceptance.

The **Intended Completion Date** is the date on which it is intended that the Contractor shall complete the Works. The Intended Completion Date is specified in the **Contract Data Sheet**. The Intended Completion Date may be revised only by the Contract Administrator by issuing an extension of time or an acceleration order.

Materials are all supplies, including consumables, used by the Contractor for incorporation in the Works.

Plant is any integral part of the Works that shall have a mechanical, electrical, chemical, or biological function.

The **Contract Administrator** is the person named in the **Contract Data Sheet** (or any other competent person appointed by the Procuring Entity and notified to the Contractor, to act in replacement of the Contract Administrator) who is responsible for supervising the execution of the Works and administering the Contract and shall be an "Architect" or a "Quantity Surveyor" registered under the Architects and Quantity Surveyors Act Cap 525 or an "Engineer" registered under Engineers Registration Act Cap 530.

The **Site** is the area defined as such in the **Contract Data Sheet**.

Site Investigation Reports are those that were included in the Tendering documents and are factual and interpretative reports about the surface and subsurface conditions at the Site.

Specification means the Specification of the Works included in the Contract and any modification or addition made or approved by the Contract Administrator.

The **Start Date** is given in the **Contract Data Sheet**. It is the latest date when the Contractor shall commence execution of the Works. It does not necessarily coincide with any of the Site Possession Dates.

A **Subcontractor** is a person or corporate body who has a

Contract with the Contractor to carry out a part of the work in the Contract, which includes work on the Site.

Temporary Works are works designed, constructed, installed, and removed by the Contractor that are needed for construction or installation of the Works.

A **Variation** is an instruction given by the Contract Administrator that varies the Works.

The **Works** are what the Contract requires the Contractor to construct, install, and turn over to the Procuring Entity, as defined in the **Contract Data Sheet**.

“**Force Majeure**” means an event which is beyond the reasonable control of a Party and which makes a Party’s performance of its obligations under the Contract impossible or so impractical as to be considered impossible under the circumstances.

2. Interpretation

- 2.1 In interpreting these Conditions of Contract, singular also means plural, male also means female or neuter, and the other way round. Headings have no significance. Words have their normal meaning under the language of the Contract unless specifically defined. The Contract Administrator will provide instructions clarifying queries about these Conditions of Contract.
- 2.2 If sectional completion is specified in the **Contract Data Sheet**, references in the Conditions of Contract to the Works, the Completion Date, and the Intended Completion Date apply to any Section of the Works (other than references to the Completion Date and Intended Completion Date for the whole of the Works).
- 2.3 The documents forming the Contract shall be interpreted in the order of priority given in the **Contract Data Sheet**:
 - (1) Agreement;
 - (2) Letter of Acceptance;
 - (3) Contract Data Sheet;
 - (4) Conditions of Contract;
 - (5) Technical Specifications;
 - (6) Contractor’s Tender;
 - (7) Drawings;
 - (8) Bill of Quantities; and
 - (9) Any other document listed in the **Contract Data Sheet** as forming part of the Contract.

3. Language, Law, Fraud and Corruption

- 3.1 The language of the Contract and the law governing the Contract are stated in the **Contract Data Sheet**.
- 3.2 The Government requires that Procuring Entities (including beneficiaries of Government funded projects) as well as Tenderers/Suppliers/Contractors under Government financed contracts, observe the highest standard of ethics during the procurement and execution of such contracts. It is the responsibility of the Procuring Entity to ensure that Tenderers, suppliers, and contractors and their subcontractors observe the highest standard of ethics during the procurement and execution of such contracts. In pursuance of this policy:

For the purpose of this provision, the following definitions are provided:

- (i). **“Corruption”** has the meaning assigned to it in the Anti Corruption and Economic Crime Act 2003 and includes the offering, giving, receiving or soliciting of anything of value to influence the action of a public official in the procurement or disposal process or in contract execution;
- (ii). **“Fraudulent Practice”** includes a misrepresentation of fact in order to influence a procurement or disposal process or the execution of a contract to the detriment of the Procuring Entity and includes collusive practices amongst Tenderers prior to or after Tender submission designed to establish Tender prices at artificial non competitive levels and deprive the Procuring Entity of the benefits of free and open competition;
- (iii). **“Collusive Practice”** means an arrangement between two or more suppliers, contractors and subcontractors designed to achieve an improper purpose, including to influence improperly the actions of the Procuring Entity prior to or after Tender submission, designed to establish Tender prices at artificial non competitive levels and to deprive the Procuring Entity of the benefit of free and open competition;
- (iv). **“Coercive Practice”** means impairing or harming, or threatening to impair or harm, directly or indirectly a supplier, contractor or subcontractor or the property of any of them to influence improperly the actions of a Procuring

Entity;

- (v). **“Obstructive Practice”** means deliberately destroying, falsifying, altering or concealing of evidence material to the investigation or making false statements to investigators in order to materially impede an investigation into allegations of a corrupt, fraudulent, coercive or collusive practice; and /or threatening, harassing or intimidating any party to prevent it from disclosing its knowledge of matters relevant to the investigation or from pursuing the investigation.

A Procuring Entity has the right to require that Tenderers, suppliers, and contractors and their subcontractors permit persons duly appointed by KACC/PPOA/KNAO to inspect their accounts and records and other documents relating to the Tender submission and contract performance;

The Procuring Entity will reject a proposal for award if it determines that the Tenderer recommended for award has engaged in corrupt, fraudulent practices or others stated under Clause 44.1.a in competing for the contract;

In pursuit of the policy defined in sub-Clause 44.1 the Procuring Entity will cancel the portion of the funds allocated to a contract for goods, works, or services if it at any time determines that corrupt or fraudulent practices were engaged in by representatives of the Procuring Entity or Approving Authority or of a beneficiary of the funds during the procurement or the execution of that contract;

In the event that the Procuring Entity or Approving Authority does not take timely and appropriate action satisfactory to the Government of Kenya to remedy the situation, then the Director-General may order an investigation of procurement proceedings for the purpose of determining whether there has been a breach of the Public Procurement and Disposal Act, 2005.

- 3.3 The Director-General may, on the advice of the Advisory Board, debar a person from participating in procurement proceedings on the ground that the person has committed an offence under the Public Procurement and Disposal Act, 2005. A debarment shall be for a period of time of not less than five years. Before a person is so debarred, he/she will be given an opportunity to make

representations to the Director-General and may request the Review Board to review the debarment.

3.4 Any communication between the Tenderers and the Procuring Entity related to matters of alleged fraud or corruption must be made in writing.

4. Confidentiality 4.1 The Service Providers, their Subcontractors, and the Personnel of either of them shall not disclose any proprietary or confidential information relating to the Project, the Services, this Contract, or the Procuring Entity's business or operations without the prior written consent of the Procuring Entity.

5. Contract Administrator's Decisions 5.1 Except where otherwise specifically stated, the Contract Administrator will decide contractual matters between the Procuring Entity and the Contractor in the role representing the Procuring Entity.

6. Delegation 6.1 The Contract Administrator may delegate any of his duties and responsibilities to other people except to the Adjudicator, after notifying the Contractor, and may cancel any delegation after notifying the Contractor.

7. Communications 7.1 Communications between parties that are referred to in the Conditions shall be effective only when in writing. A notice shall be effective only when it is delivered.

8. Subcontracting 8.1 The Contractor may subcontract with the approval of the Contract Administrator, but may not assign the Contract without the approval of the Procuring Entity in writing. Subcontracting shall not alter the Contractor's obligations.

9. Other Contractors 9.1 The Contractor shall cooperate and share the Site with other contractors, public authorities, utilities, and the Procuring Entity between the dates given in the Schedule of Other Contractors, as referred to in the **Contract Data Sheet**. The Contractor shall also provide facilities and services for them as described in the Schedule. The Procuring Entity may modify the Schedule of Other Contractors, and shall notify the Contractor of any such modification

10. Personnel 10.1 The Contractor shall employ the key personnel named in the Schedule of Key Personnel, as referred to in the **Contract Data Sheet**, who shall be appropriately qualified and registered with the appropriate bodies to carry out the functions stated in the Schedule or other personnel approved by the Contract Administrator. The Contract Administrator will approve any proposed replacement of

key personnel only if their relevant qualifications and abilities are substantially equal to or better than those of the personnel listed in the Schedule.

10.2 If the Contract Administrator asks the Contractor to remove a person who is a member of the Contractor's staff or work force, stating the reasons, the Contractor shall ensure that the person leaves the Site within seven days and has no further connection with the work in the Contract.

11. Procuring Entity's and Contractor's Risks

11.1 The Procuring Entity carries the risks which this Contract states are Procuring Entity's risks, and the Contractor carries the risks which this Contract states are Contractor's risks.

12. Procuring Entity's Risks

12.1 From the Start Date until the Defects Correction Certificate has been issued, the following are Procuring Entity's risks:

- a) The risk of personal injury, death, or loss of or damage to property (excluding the Works, Plant, Materials, and Equipment), which are due to:
 - (i) Use or occupation of the Site by the Works or for the purpose of the Works, which is the unavoidable result of the Works; or
 - (ii) Negligence, breach of statutory duty, or interference with any legal right by the Procuring Entity or by any person employed by or contracted to him except the Contractor.
- b) The risk of damage to the Works, Plant, Materials, and Equipment to the extent that it is due to a fault of the Procuring Entity or in the Procuring Entity's design, or due to war or radioactive contamination directly affecting the country where the Works are to be executed.

12.2 From the Completion Date until the Defects Correction Certificate has been issued, the risk of loss of or damage to the Works, Plant, and Materials is an Procuring Entity's risk except loss or damage due to:

- (a) A Defect which existed on the Completion Date;
- (b) An event occurring before the Completion Date, which was not itself an Procuring Entity's risk; or
- (c) The activities of the Contractor on the Site after the

Completion Date.

13. Contractor's Risks

13.1 From the Starting Date until the Defects Correction Certificate has been issued, the risks of personal injury, death, and loss of or damage to property (including, without limitation, the Works, Plant, Materials, and Equipment) which are not Procuring Entity's risks are Contractor's risks.

14. Insurance

14.1 The Contractor shall provide, in the joint names of the Procuring Entity and the Contractor, insurance cover from the Start Date to the end of the Defects Liability Period, in the amounts and deductibles stated in the **Contract Data Sheet** for the following events which are due to the Contractor's risks:

- (a) Loss of or damage to the Works, Plant, and Materials;
- (b) Loss of or damage to Equipment;
- (c) Loss of or damage to property (except the Works, Plant, Materials, and Equipment) in connection with the Contract; and
- (d) Personal injury or death.

14.2 Policies and certificates for insurance shall be delivered by the Contractor to the Contract Administrator for the Contract Administrator's approval before the Start Date. All such insurance shall provide for compensation to be payable in the types and proportions of currencies required to rectify the loss or damage incurred.

14.3 If the Contractor does not provide any of the policies and certificates required, the Procuring Entity may effect the insurance which the Contractor should have provided and recover the premiums the Procuring Entity has paid from payments otherwise due to the Contractor or, if no payment is due, the payment of the premiums shall be a debt due.

14.4 Alterations to the terms of insurance shall not be made without the approval of the Contract Administrator.

14.5 Both parties shall comply with any conditions of the insurance policies.

15. Site Investigation Reports

15.1 The Contractor, in preparing the Tender, shall rely on any Site Investigation Reports referred to in the **Contract Data Sheet**, supplemented by any information available to

- the Tenderers.
- 16. Queries about the Contract Data Sheet** 16.1 The Contract Administrator will clarify queries on the **Contract Data Sheet**.
- 17. Contractor to Construct the Works** 17.1 The Contractor shall construct and install the Works in accordance with the Specifications and Drawings.
- 18. Commencement and Completion** 18.1 The Contractor may commence execution of the Works on the Start Date and shall carry out the Works in accordance with the Programme submitted by the Contractor, as updated with the approval of the Project Manager, and complete them by the Intended Completion Date.
- 19. Approval by the Contract Administrator** 19.1 The Contractor shall submit Specifications and Drawings showing the proposed Temporary Works to the Contract Administrator, who is to approve them if they comply with the Specifications and Drawings.
- 19.2 The Contractor shall be responsible for the design of Temporary Works.
- 19.3 The Contract Administrator’s approval shall not alter the Contractor’s responsibility for design of the Temporary Works.
- 19.4 The Contractor shall obtain approval of third parties to the design of the Temporary Works, where required.
- 19.5 All Drawings prepared by the Contractor for the execution of the temporary or permanent Works, are subject to prior approval by the Project Manager before their use.
- 20. Protection of the Environment** 20.1 The Contractors shall take all reasonable steps to protect the environment and to limit damage and nuisance to people and property resulting from pollution, noise and other results of his operations.
- 20.2 The Contractors shall ensure that emissions, surface discharges and effluent from his activities shall not exceed prescribed values in the environmental laws.
- 21. Labour Laws** 21.2 The Contractor shall comply with all the relevant labour laws applicable in the Country, including laws relating to workers’ employment, working hours, health, safety, welfare, and immigration, and shall allow them all their legal rights.
- 21.2 The Contractor shall require his employees to obey all applicable laws, including those concerning safety at

work.

22. Health and Safety

- 22.1 The Contractor shall at all times take all reasonable precautions to maintain the health and safety of his personnel.
- 22.2 The Contractor shall ensure that first aid facilities are available at all times at the site and that suitable arrangements are made for all necessary welfare and hygiene requirements and for the prevention of epidemics.
- 22.3 The Contractor shall notify the Procuring Entity details of any accident as soon as practicable after its occurrence. The Contractor shall maintain records and make reports concerning health, safety, and welfare of persons, and damage to the property, as the Procuring Entity may reasonably require.
- 22.4 The Contractor shall conduct an HIV-Aids awareness programme, and shall take other such measures as specified in the **Contract Data Sheet** to reduce the risk of transfer of HIV virus between and among Contractor personnel, the Procuring Entity's Staff and the surrounding community.

23. Discoveries

- 23.1 Anything of historical or other interest or of significant value unexpectedly discovered on the Site shall be the property of the Procuring Entity. The Contractor shall notify the Contract Administrator of such discoveries and carry out the Contract Administrator's instructions for dealing with them.

24. Possession of the Site

- 24.1 The Procuring Entity shall give possession of all parts of the Site to the Contractor. If possession of a part is not given by the date stated in the **Contract Data Sheet**, the Procuring Entity will be deemed to have delayed the start of the relevant activities, and this will be a Compensation Event.

25. Access to the Site

- 25.1 The Contractor shall allow the Contract Administrator and any person authorized by the Contract Administrator access to the Site and to any place where work in connection with the Contract is being carried out or is intended to be carried out.

26. Instructions, Inspections and Audits

- 26.1 The Contractor shall carry out all instructions of the Contract Administrator which comply with the applicable laws where the Site is located.
- 26.2 The Contractor shall permit the Kenya Government to

inspect the Contractor's accounts and records relating to the performance of the Contractor and to have them audited by auditors appointed by the Kenya Government, if so required by the Kenya Government

27. Disputes

27.1 If the Contractor believes that a decision taken by the Contract Administrator was either outside the authority given to the Contract Administrator by the Contract or that the decision was wrongly taken, the decision shall be referred to the Adjudicator within 14 days of the notification of the Contract Administrator's decision.

28. Procedure for Disputes

28.1 The Adjudicator shall give a decision in writing within 28 days of receipt of a notification of a dispute.

28.2 The Adjudicator shall be paid by the hour at the rate specified in the **Tender Data Sheet** and **Contract Data Sheet**, together with reimbursable expenses of the types specified in the **Contract Data Sheet**, and the cost shall be divided equally between the Procuring Entity and the Contractor, whatever decision is reached by the Adjudicator. Either party may refer a decision of the Adjudicator to an Arbitrator within 28 days of the Adjudicator's written decision. If neither party refers the dispute to arbitration within the above 28 days, the Adjudicator's decision will be final and binding.

28.3 The arbitration shall be conducted in accordance with the arbitration procedure published by the institution named and in the place shown in the **Contract Data Sheet**.

29. Replacement of Adjudicator

29.1 Should the Adjudicator resign or die, or should the Procuring Entity and the Contractor agree that the Adjudicator is not functioning in accordance with the provisions of the Contract, a new Adjudicator will be jointly appointed by the Procuring Entity and the Contractor. In case of disagreement between the Procuring Entity and the Contractor, within 30 days, the Adjudicator shall be designated by the Appointing Authority designated in the **Contract Data Sheet** at the request of either party, within 14 days of receipt of such request.

B. Time Control

- | | |
|--|--|
| 30. Programme | <p>30.1 Within the time stated in the Contract Data Sheet, the Contractor shall submit to the Contract Administrator for approval a Programme showing the general methods, arrangements, order, and timing for all the activities in the Works.</p> <p>30.2 An update of the Programme shall be a programme showing the actual progress achieved on each activity and the effect of the progress achieved on the timing of the remaining work, including any changes to the sequence of the activities.</p> <p>30.3 The Contractor shall submit to the Contract Administrator for approval an updated Programme at intervals no longer than the period stated in the Contract Data Sheet. If the Contractor does not submit an updated Programme within this period, the Contract Administrator may withhold the amount stated in the Contract Data Sheet from the next payment certificate and continue to withhold this amount until the next payment after the date on which the overdue Programme has been submitted.</p> <p>30.4 The Contract Administrator's approval of the Programme shall not alter the Contractor's obligations. The Contractor may revise the Programme and submit it to the Contract Administrator again at any time. A revised Programme shall show the effect of Variations and Compensation Events</p> |
| 31. Extension of the Intended Completion Date | <p>31.1 The Contract Administrator shall extend the Intended Completion Date if a Compensation Event occurs or a Variation is issued which makes it impossible for Completion to be achieved by the Intended Completion Date without the Contractor taking steps to accelerate the remaining work, which would cause the Contractor to incur additional cost.</p> <p>31.2 The Contract Administrator shall decide whether and by how much to extend the Intended Completion Date within 21 days of the Contractor asking the Contract Administrator for a decision upon the effect of a Compensation Event or Variation and submitting full supporting information. If the Contractor has failed to give early warning of a delay or has failed to cooperate in dealing with a delay, the delay by this failure shall not be considered in assessing the new Intended Completion Date.</p> |

- 32. Acceleration**
- 32.1 When the Procuring Entity wants the Contractor to finish before the Intended Completion Date, the Contract Administrator will obtain priced proposals for achieving the necessary acceleration from the Contractor. If the Procuring Entity accepts these proposals, the Intended Completion Date will be adjusted accordingly and confirmed by both the Procuring Entity and the Contractor.
- 32.2 If the Contractor’s priced proposals for acceleration are accepted by the Procuring Entity, they shall be incorporated in the Contract Price and treated as a Variation.
- 33. Delays Ordered by the Contract Administrator**
- 33.1 The Contract Administrator may instruct the Contractor to delay the start or progress of any activity within the Works.
- 34. Management Meetings**
- 34.1 Either the Project manager or the Contractor may require the other to attend a management meeting. The business of a management meeting shall be to review the plans for remaining work and to deal with matters raised in accordance with the early warning procedure.
- 34.2 The Project manager shall record the business of management meetings and provide copies of the record to those attending the meeting and to the Procuring Entity. The responsibility of the parties for actions to be taken shall be decided by the Contract Administrator either at the management meeting or after the management meeting and stated in writing to all who attended the meeting.
- 35. Early Warning**
- 35.1 The Contractor shall warn the Project manager at the earliest opportunity of specific likely future events or circumstances that may adversely affect the quality of the work, increase the Contract Price or delay the execution of the Works. The Contract Administrator may require the Contractor to provide an estimate of the expected effect of the future event or circumstance on the Contract Price and Completion Date. The estimate shall be provided by the Contractor as soon as reasonably possible.
- 35.2 The Contractor shall cooperate with the Project manager in making and considering proposals for how the effect of such an event or circumstance can be avoided or reduced by anyone involved in the work and in carrying out any resulting instruction of the Contract Administrator.

C. Quality Control

- | | |
|----------------------------------|--|
| 36. Identifying Defects | 36.1 The Contract Administrator shall check the Contractor’s work and notify the Contractor of any Defects that are found. Such checking shall not affect the Contractor’s responsibilities. The Contract Administrator may instruct the Contractor to search for a Defect and to uncover and test any work that the Contract Administrator considers may have a Defect. |
| 37. Tests | 37.1 If the Contract Administrator instructs the Contractor to carry out a test not specified in the Specification to check whether any work has a Defect and the test shows that it does, the Contractor shall pay for the test and any samples. If there is no Defect, the test shall be a Compensation Event. |
| 38. Correction of Defects | <p>38.1 The Contract Administrator shall give notice to the Contractor of any Defects before the end of the Defects Liability Period, which begins at Completion, and is defined in the Contract Data Sheet. The Defects Liability Period shall be extended for as long as Defects remain to be corrected.</p> <p>38.2 Every time notice of a Defect is given, the Contractor shall correct the notified Defect within the length of time specified by the Contract Administrator’s notice.</p> <p>38.3 If the Contractor has not corrected a defect within the time specified in the Procuring Entity’s notice, a penalty for lack of performance will be paid by the Contractor. The amount to be paid will be calculated as a percentage of the cost of having the defect correct, assessed as described in Clause 39.</p> |
| 39. Uncorrected Defects | 39.1 If the Contractor has not corrected a Defect within the time specified in the Contract Administrator’s notice, the Contract Administrator will assess the cost of having the Defect corrected, and the Contractor will pay this amount. |

D. Cost Control

- | | |
|-------------------------------|--|
| 40. Bill of Quantities | <p>40.1 The Bill of Quantities shall contain items for the construction, installation, testing, and commissioning work to be done by the Contractor.</p> <p>40.2 The Bill of Quantities is used to calculate the Contract Price. The Contractor shall be paid for the quantity of the work done at the rate in the Bill of Quantities for each</p> |
|-------------------------------|--|

item.

41. Changes in the Quantities

- 41.1 If the final quantity of the work done differs from the quantity in the Bill of Quantities for the particular item by more than 25 percent, provided the change exceeds 1 percent of the Initial Contract Price, the Contract Administrator shall adjust the rate to allow for the change.
- 41.2 The Contract Administrator shall not adjust rates from changes in quantities if thereby the Initial Contract Price is exceeded by more than 15 percent, except with the prior approval of the Procuring Entity.
- 41.3 If requested by the Contract Administrator, the Contractor shall provide the Contract Administrator with a detailed cost breakdown of any rate in the Bill of Quantities.

42. Variations

- 42.1 All Variations shall be included in the updated Programmes produced by the Contractor.

43. Payments for Variations

- 43.1 The Contractor shall provide the Contract Administrator with a quotation for carrying out the Variation when requested to do so by the Contract Administrator. The Contract Administrator shall assess the quotation, which shall be given within seven days of the request or within any longer period stated by the Contract Administrator and before the Variation is ordered.
- 43.2 If the work in the Variation corresponds with an item description in the Bill of Quantities and if, in the opinion of the Contract Administrator, the quantity of work is above the limit stated in Sub-Clause 41.1 or the timing of its execution do not cause the cost per unit of quantity to change, the rate in the Bill of Quantities shall be used to calculate the value of the Variation. If the cost per unit of quantity changes, or if the nature or timing of the work in the Variation does not correspond with items in the Bill of Quantities, the quotation by the Contractor shall be in the form of new rates for the relevant items of work.
- 43.3 If the Contractor's quotation is unreasonable, the Contract Administrator may order the Variation and make a change to the Contract Price, which shall be based on the Contract Administrator's own forecast of the effects of the Variation on the Contractor's costs.
- 43.4 If the Contract Administrator decides that the urgency of varying the work would prevent a quotation being given and considered without delaying the work, no quotation shall be given and the Variation shall be treated as a

Compensation Event.

43.5 The Contractor shall not be entitled to additional payment for costs that could have been avoided by giving early warning.

44. Cash Flow Forecasts

44.1 When the Programme is updated, the Contractor shall provide the Contract Administrator with an updated cash flow forecast. The cash flow forecast shall include different currencies, as defined in the Contract, converted as necessary using the Contract exchange rates.

45. Payment Certificates

45.1 The Contractor shall submit to the Contract Administrator monthly statements of the estimated value of the work executed less the cumulative amount certified previously.

45.2 The Contract Administrator shall check the Contractor's monthly statement and certify the amount to be paid to the Contractor within twenty-eight 28 days of receipt of the certificate from the contractor.

45.3 The value of work executed shall be determined by the Contract Administrator.

45.4 The value of work executed shall comprise the value of the quantities of the items in the Bill of Quantities completed.

45.5 The value of work executed shall include the valuation of Variations and Compensation Events.

45.6 The Contract Administrator may exclude any item certified in a previous certificate or reduce the proportion of any item previously certified in any certificate in the light of later information.

45.7 The Contract Administrator shall not be bound to certify any payment, if the net amount, after all retentions and deductions would be less than minimum amount of Interim Payment Certificate stated in the **Contract Data Sheet**.

46. Payments

46.1 Payments shall be adjusted for deductions for advance payments and retention. The Procuring Entity shall pay the Contractor the amounts certified by the Contract Administrator within 28 days of the date of each certificate. If the Procuring Entity makes a late payment, the Contractor shall be paid interest on the late payment in the next payment Interest shall be calculated from the date by which the payment should have been made up to the date when the late payment is made at the prevailing rate of interest for commercial borrowing for each of the currencies in which payments are made as indicated in the

Contract Data Sheet.

- 46.2 If an amount certified is increased in a later certificate or as a result of an award by the Adjudicator or an Arbitrator, the Contractor shall be paid interest upon the delayed payment as set out in this clause. Interest shall be calculated from the date upon which the increased amount would have been certified in the absence of dispute.
- 46.3 Unless otherwise stated, all payments and deductions will be paid or charged in the proportions of currencies comprising the Contract Price.
- 46.4 Items of the Works for which no rate or price has been entered in will not be paid for by the Procuring Entity and shall be deemed covered by other rates and prices in the Contract.

47. Compensation Events

- 47.1 The following shall be Compensation Events:
 - (a) The Procuring Entity does not give access to a part of the Site by the Site Possession Date stated in the **Contract Data Sheet**.
 - (b) The Procuring Entity modifies the Schedule of Other Contractors in a way that affects the work of the Contractor under the Contract.
 - (c) The Contract Administrator orders a delay or does not issue Drawings, Specifications, or instructions required for execution of the Works on time.
 - (d) The Contract Administrator instructs the Contractor to uncover or to carry out additional tests upon work, which is then found to have no Defects.
 - (e) The Contract Administrator unreasonably does not approve a subcontract to be let.
 - (f) Ground conditions are substantially more adverse than could reasonably have been assumed before issuance of the Letter of Acceptance from the information issued to Tenderers (including the Site Investigation Reports), from information available publicly and from a visual inspection of the Site.
 - (g) The Contract Administrator gives an instruction for dealing with an unforeseen condition, caused by the Procuring Entity, or additional work required for safety or other reasons.
 - (h) Other contractors, public authorities, utilities, or the

Procuring Entity does not work within the dates and other constraints stated in the Contract, and they cause delay or extra cost to the Contractor.

- (i) The advance payment is delayed.
- (j) The effects on the Contractor of any of the Procuring Entity's Risks.
- (k) The Contract Administrator unreasonably delays issuing a Certificate of Completion.
- (l) Other Compensation Events described in the Contract or determined by the Contract Administrator shall apply.

47.2 If a Compensation Event would cause additional cost or would prevent the work being completed before the Intended Completion Date, the Contract Price shall be increased and/or the Intended Completion Date shall be extended. The Contract Administrator shall decide whether and by how much the Contract Price shall be increased and whether and by how much the Intended Completion Date shall be extended.

47.3 As soon as information demonstrating the effect of each Compensation Event upon the Contractor's forecast cost has been provided by the Contractor, it shall be assessed by the Contract Administrator, and the Contract Price shall be adjusted accordingly. If the Contractor's forecast is deemed unreasonable, the Contract Administrator shall adjust the Contract Price based on the Contract Administrator's own forecast. The Contract Administrator will assume that the Contractor will react competently and promptly to the event.

47.4 The Contractor shall not be entitled to compensation to the extent that the Procuring Entity's interests are adversely affected by the Contractor's not having given early warning or not having cooperated with the Contract Administrator.

48. Taxes

48.1 The Contract Administrator shall adjust the Contract Price if taxes, duties, and other levies are changed between the date 28 days before the submission of Tenders for the Contract and the date of the last Completion certificate. The adjustment shall be the change in the amount of tax payable by the Contractor, provided such changes are not already reflected in the Contract Price or are a result of

Clause 50.

49. Currencies

49.1 Where payments are made in currencies other than the Kenya Shillings, the exchange rates used for calculating the amounts to be paid shall be the exchange rates stated in the Contractor's Tender.

50. Price Adjustment

50.1 The amounts payable to the Contractor, in various currencies pursuant to Sub-Clause 45.1, shall be adjusted in respect of the rise or fall in the cost of labour, Contractor's Equipment, Plant, materials, and other inputs to the Works, by applying to such amounts the formulae prescribed in this clause based on the prevailing consumer price index obtained from the Central Bureau of Statistics or the monthly inflation rate issued by the Central Bank of Kenya.

50.2 To the extent that full compensation for any rise or fall in costs to the Contractor is not covered by the provisions of this or other clauses in the Contract, the unit rates and prices included in the Contract shall be deemed to include amounts to cover the contingency of such other rise or fall of costs.

50.3 The adjustment to be applied to amount payable to the Contractor as certified in Payment Certificates shall be determined formulae for each of the currencies in which the Contract Price is payable. No adjustment is to be applied to work valued on the basis of Cost or current prices. The formulae shall be as follows;

$$P_n = a + b \frac{L_n - L_o}{L_o} + c \frac{M_n - M_o}{M_o} + d \frac{E_n - E_o}{E_o} + etc.$$

where;

P_n is a price adjustment factor to be applied to the amount in each specific currency for the payment of the work carried out in the subject month, where such variations and day work are not otherwise subject to adjustment;

a is a constant, specified in the **Appendix to Tender**, representing the nonadjustable portion in contractual payments;

b, c, d, etc., are weightings or coefficients representing the estimated proportion of each cost element (labour, materials, equipment usage, etc.) in the Works or sections thereof, net of Provisional Sums, as specified in the **Appendix to Tender**; the sum of a, b, c, d, etc., shall be one;

Ln, Mn, En, etc., are the current cost indices or reference prices of the cost elements in the specific currency of origin for month “**n**,” determined pursuant to Sub-Clause 50.5, applicable to each cost element; and

Lo, Mo, Eo, etc., are the base cost indices or reference prices corresponding to the above cost elements at the date specified in Sub-Clause 50.5

The value of net work done, certified by the Contract Administrator, in any monthly Interim or Final Certificate as payable by the Procuring Entity to the Contractor before deduction of any retention money shall be increased or decreased by an amount of ‘**F**’.

$$F = P_n x P_c$$

where;

The effective value **Pc** of work done which is to be subjected to increase or decrease shall be the difference between:

- (i) the amount which, in the opinion of the Contract Administrator, is due to the Contractor under Clause 45 (before deduction of retention money and before deducting sums previously paid on account) less:
 - any amount for payment or repayment of any advance payment;
 - any amount for materials on site (if any);
 - any amounts for nominated sub-contractors (if any)
 - any amounts for any other items based on actual cost or current prices; or
 - any sums for increase or decreases in the Contract Price paid under this Sub-Clause

and
- (ii) the amount calculated in accordance with (i) above of this Sub-clause and included in the last preceding statement.

50.4 The sources of indices shall be those listed in the **Appendix to Tender**, as approved by the Engineer. Indices shall be appropriate for their purpose and shall relate to the Contractor’s proposed source of supply of inputs on the basis of which his Contract Price and expected foreign currency requirements shall have been computed. As the proposed basis for price adjustment, the Contractor shall have submitted with his Tender the tabulation of Weightings and Source of Indices in the

Appendix to Tender, which shall be subject to approval by the Engineer.

50.5 The base cost indices or prices shall be those prevailing on the day 28 days prior to the latest date for submission of Tenders. Current indices or prices shall be those prevailing on the day 28 days prior to the last day of the period to which a particular Interim Payment Certificate is related. If at any time the current indices are not available, provisional indices as determined by the Engineer will be used, subject to subsequent correction of the amounts paid to the Contractor when the current indices become available.

50.6 If the Contractor fails to complete the Works within the time for completion prescribed under Clause 58 adjustment of prices thereafter until the date of completion of the Works shall be made using either the indices or prices relating to the prescribed time for completion, or the current indices or prices, whichever is more favourable to the Procuring Entity, provided that if an extension of time is granted pursuant to Clause 28, the above provision shall apply only to adjustments made after the expiry of such extension of time.

50.7 The weightings for each of the factors of cost given in the **Appendix to Tender** shall be adjusted if, in the opinion of the Engineer, they have been rendered unreasonable, unbalanced, or inapplicable as a result of varied or additional work already executed or instructed under Clause 43 or for any other reason.

51. Retention

51.1 The Procuring Entity shall retain from each payment due to the Contractor the proportion stated in the **Contract Data Sheet** until Completion of the whole of the Works.

51.2 On completion of the whole of the Works, half the total amount retained shall be repaid to the Contractor and the other half when the Defects Liability Period has passed and the Contract Administrator has certified that all Defects notified by the Contract Administrator to the Contractor before the end of this period have been corrected.

51.3 On completion of the whole Works, the Contractor may substitute retention money with an “on demand” Bank guarantee.

52. Liquidated Damages

52.1 The Contractor shall pay liquidated damages to the Procuring Entity at the rate per day stated in the **Contract**

Data Sheet for each day that the Completion Date is later than the Intended Completion Date. The total amount of liquidated damages shall not exceed the amount defined in the **Contract Data Sheet**. The Procuring Entity may deduct liquidated damages from payments due to the Contractor. Payment of liquidated damages shall not affect the Contractor's liabilities.

- 52.2 If the Intended Completion Date is extended after liquidated damages have been paid, the Contract Administrator shall correct any overpayment of liquidated damages by the Contractor by adjusting the next payment certificate. The Contractor shall be paid interest on the overpayment, calculated from the date of payment to the date of repayment, at the rates specified in Sub-Clause 46.1.
- 52.3 If the Contractor has not corrected a defects within the time specified in the Procuring Entity's notice, the Procuring Entity will assess the cost of having the defect corrected, the Contractor will pay this amount, and a penalty for lack of performance calculated as described in Clause 38.

53. Bonus

- 53.1 The Contractor shall be paid a Bonus calculated at the rate per calendar day stated in the **Contract Data Sheet** for each day (less any days for which the Contractor is paid for acceleration) that the Completion is earlier than the Intended Completion Date. The Contract Administrator shall certify that the Works are complete, although they may not be due to be complete.

54. Advance Payment

- 54.1 The Procuring Entity shall make advance payment to the Contractor of the amounts stated in the **Contract Data Sheet** by the date stated in the **Contract Data Sheet**, against provision by the Contractor of an Unconditional Bank Guarantee in a form and by a bank acceptable to the Procuring Entity in amounts and currencies equal to the advance payment. The Guarantee shall remain effective until the advance payment has been repaid, but the amount of the Guarantee shall be progressively reduced by the amounts repaid by the Contractor. Interest will not be charged on the advance payment.
- 54.2 The Contractor is to use the advance payment only to pay for Equipment, Plant, Materials, and mobilization expenses required specifically for execution of the Contract. The Contractor shall demonstrate that advance payment has been used in this way by supplying copies of

invoices or other documents to the Contract Administrator.

54.3 The advance payment shall be repaid by deducting proportionate amounts from payments otherwise due to the Contractor, following the schedule of completed percentages of the Works on a payment basis. No account shall be taken of the advance payment or its repayment in assessing valuations of work done, Variations, price adjustments, Compensation Events, Bonuses, or Liquidated Damages.

55. Performance Securities

55.1 The Performance Security shall be provided to the Procuring Entity no later than the date specified in the Letter of Acceptance and shall be issued in an amount and form and by a bank or surety acceptable to the Procuring Entity, and denominated in the types and proportions of the currencies in which the Contract Price is payable. The Performance Security shall be valid until a date 28 days from the date of issue of the Certificate of Completion in the case of a Bank Guarantee, and until one year from the date of issue of the Completion Certificate in the case of a Performance Bond.

56. Day works

56.1 If applicable, the Dayworks rates in the Contractor's Tender shall be used for small additional amounts of work only when the Contract Administrator has given written instructions in advance for additional work to be paid for in that way.

56.2 All work to be paid for as Dayworks shall be recorded by the Contractor on forms approved by the Contract Administrator. Each completed form shall be verified and signed by the Contract Administrator within two days of the work being done.

56.3 The Contractor shall be paid for Dayworks subject to obtaining signed Dayworks forms.

57. Cost of Repairs

57.1 Loss or damage to the Works or Materials to be incorporated in the Works between the Start Date and the end of the Defects Correction periods shall be remedied by the Contractor at the Contractor's cost if the loss or damage arises from the Contractor's acts or omissions.

E. Finishing the Contract

58. Completion Certificate

58.1 The Contractor shall request the Contract Administrator to issue a certificate of Completion of the Works, and the Contract Administrator will do so upon deciding that the

work is completed.

59. Taking Over 59.1 The Procuring Entity shall take over the Site and the Works within seven days of the Contract Administrator’s issuing a certificate of Completion.

60. Final Account 60.1 The Contractor shall supply the Contract Administrator with a detailed account of the total amount that the Contractor considers payable under the Contract before the end of the Defects Liability Period. The Contract Administrator shall issue a Defects Liability Certificate and certify any final payment that is due to the Contractor within 56 days of receiving the Contractor’s account if it is correct and complete. If it is not, the Contract Administrator shall issue within 56 days a schedule that states the scope of the corrections or additions that are necessary. If the Final Account is still unsatisfactory after it has been resubmitted, the Contract Administrator shall decide on the amount payable to the Contractor and issue a payment certificate.

61. Operating and Maintenance Manuals 61.1 If “as built” Drawings and/or operating and maintenance manuals are required, the Contractor shall supply them by the dates stated in the **Contract Data Sheet**.

61.2 If the Contractor does not supply the Drawings and/or manuals by the dates stated in the **Contract Data Sheet**, or they do not receive the Contract Administrator’s approval, the Contract Administrator shall withhold the amount stated in the **Contract Data Sheet** from payments due to the Contractor.

62. Termination 62.1 The Procuring Entity or the Contractor may terminate the Contract if the other party causes a fundamental breach of the Contract.

62.2 Fundamental breaches of Contract shall include, but shall not be limited to, the following:

- (a) The Contractor stops work for 28 days when no stoppage of work is shown on the current Programme and the stoppage has not been authorized by the Contract Administrator;
- (b) The Contract Administrator instructs the Contractor to delays the progress of the Works, and the instruction is not withdrawn within 28 days;
- (c) The Procuring Entity or the Contractor is made bankrupt or goes into liquidation other than for a

reconstruction or amalgamation;

- (d) A payment certified by the Contract Administrator is not paid by the Procuring Entity to the Contractor within 84 days of the date of the Contract Administrator's certificate;
- (e) The Contract Administrator gives Notice that failure to correct a particular Defect is a fundamental breach of Contract and the Contractor fails to correct it within a reasonable period of time determined by the Contract Administrator;
- (f) The Contractor does not maintain a Security, which is required; and
- (g) The Contractor has delayed the completion of the Works by the number of days for which the maximum amount of liquidated damages can be paid, as defined in the **Contract Data Sheet**.
- (h) If the Contractor, in the judgment of the Procuring Entity has engaged in corrupt or fraudulent practices in competing for or in executing the Contract.

For the purpose of this paragraph:

“corrupt practice” means the offering, giving, receiving or soliciting of anything of value to influence the action of a public official in the procurement process or in contract execution and includes inter alia, bribery and extortion or coercion which involves threats of injury to person, property or reputation, and.

“fraudulent practice” means a misrepresentation of facts in order to influence a procurement process or the execution of a contract to the detriment of the Procuring Entity, and includes collusive practice among Tenderers (prior to or after Tender submission) designed to establish Tender prices at artificial non-competitive levels and to deprive the Procuring Entity of the benefits of free and open competition.

62.3 When either party to the Contract gives notice of a breach of Contract to the Contract Administrator for a cause other than those listed under Sub-Clause 62.2 above, the Contract Administrator shall decide whether the breach is fundamental or not.

62.4 Notwithstanding the above, the Procuring Entity may

terminate the Contract for convenience.

62.5 If the Contract is terminated, the Contractor shall stop work immediately, make the Site safe and secure, and leave the Site as soon as reasonably possible.

63. Payment upon Termination

63.1 If the Contract is terminated because of a fundamental breach of Contract by the Contractor, the Contract Administrator shall issue a certificate for the value of the work done and Materials ordered less advance payments received up to the date of the issue of the certificate and less the percentage to apply to the value of the work not completed, as indicated in the **Contract Data Sheet**. Additional Liquidated Damages shall not apply. If the total amount due to the Procuring Entity exceeds any payment due to the Contractor, the difference shall be a debt payable to the Procuring Entity.

63.2 If the Contract is terminated for the Procuring Entity's convenience or because of a fundamental breach of Contract by the Procuring Entity, the Contract Administrator shall issue a certificate for the value of the work done, Materials ordered, the reasonable cost of removal of Equipment, repatriation of the Contractor's personnel employed solely on the Works, and the Contractor's costs of protecting and securing the Works, and less advance payments received up to the date of the certificate.

64. Property

64.1 All Materials on the Site, Plant, Equipment, Temporary Works, and Works shall be deemed to be the property of the Procuring Entity if the Contract is terminated because of the Contractor's default.

65. Release from Performance

65.1 If the Contract is frustrated by the outbreak of war or by any other event entirely outside the control of either the Procuring Entity or the Contractor, the Contract Administrator shall certify that the Contract has been frustrated. The Contractor shall make the Site safe and stop work as quickly as possible after receiving this certificate and shall be paid for all work carried out before receiving it and for any work carried out afterwards to which a commitment was made.

66. Suspension of Financing

66.1 In the event that the source of financing is suspended to the Procuring Entity, from which part of the payments to the Contractor are being made:

(a) The Procuring Entity is obligated to notify the Contractor of such suspension within 7 days of having received the

financing agency's suspension notice.

- (b) If the Contractor has not received sums due it within the 28 days for payment provided for in Sub-Clause 46.1, the Contractor may immediately issue a 14-day termination notice.

SECTION V: CONTRACT DATA SHEET (CDS)

Contract Data Sheet

Instructions for completing the Contract Data Sheet

CDS Clause	GCC Clause	Description
1	1.1	<p style="text-align: center;">A. General</p> <p>(Itemise Definitions to take the same numbering as per the General Conditions)</p> <p>The Procuring Entity is Ministry of County Government of Isiolo</p> <p>The Adjudicator is <i>The Institution of Engineers of Kenya (IEK)</i></p> <p>The Defects Liability Period is 180 days.</p> <p>The Contract Administrator is Chief Officer - Water and Sanitation-Isiolo County</p> <p>The name and identification number of the Contract is Construction/Augmentation of Modogashe water supply in isiolo south constituency Tender No ICG/WATER/001W/2024-2025</p> <p>The Works consist of: - The works involves but is not limited to the following: -</p> <ul style="list-style-type: none"> o) Drilling and Equipping 1No Borehole p) Rehabilitation and equipping of 2No. Infiltration gallery q) Construction of Generator house r) Piping -HDPE PN12.5 - Rising Main -1.2Km and 3Km dItribution line s) Construction of 15m high 100m³ Elevated Steel Tank t) Fencing u) Construction of 2No. Water Kiosks <p style="text-align: center;"><i>The objectives of the contract are to provide portable domestic water to the people of Modogashe in Sericho ward - Isiolo County.</i></p> <p>The Start Date shall be <i>Notified by the Contract Administrator.</i></p> <p>The Intended Completion Date for the whole of the Works shall</p>

SPECIFICATIONS

be **the end of 4 months after signing the contract**

		<p>The following documents also form part of the Contract:</p> <ol style="list-style-type: none"> 1. The Bills of quantities 2. The Specifications 3. Drawings <p>The Site is located <i>in as indicated in the invitation to bid</i></p>
2.	2.2	<p>Indicate whether there is sectional completion [<i>specified/not specified</i>]. <i>Not applicable</i></p>
3.	2.3(9)	<p>List other documents that form part of the contract if any:</p> <ol style="list-style-type: none"> a) Minutes of Negotiation
4.	3.1	<p>The language of the Contract documents is <i>English</i>. The law that applies to the Contract is the Kenyan Law.</p>
5.	9.1	<p>Include the Schedule of Other Contractors, if any. <i>Not Applicable</i></p>
6.	10.1	<p>Include the Schedule of Key Personnel.</p> <ol style="list-style-type: none"> 1. Site Agent 2. General Foremen 3. Electrician (Licensed at minimum of class c) 4. Power Plant Mechanic 5. Surveyor Asst. 6. Plumber 7. Mason
7.	14.1	<p>The minimum insurance covers shall be:</p> <ol style="list-style-type: none"> (a) loss of or damage to the Works, Plant, and Materials <i>Kshs 1,000,000</i> <i>Loss of or damage to Equipment</i> <i>Kshs 5,000,000</i> (b) Loss of or damage to property (except the Works, Plant, Materials, and Equipment) in connection with the Contract <i>Kshs 5,000,000</i> and (c) personal injury or death <i>Kshs 3,000,000</i>
8.	15.1	<p>Site Investigation Reports available to the Tenderers are:</p> <ol style="list-style-type: none"> a) None

SPECIFICATIONS

9.	22.4	<p>The other measures include:</p> <p>a. Minimising the number of migrant workers employed on the project and household in the site camp</p> <p>b. Providing access to voluntary counselling and testing (VCT)</p> <p>c. Providing psychological support and health care including prevention and treatment of opportunistic infections for workers infected and affected, as well as their families</p> <p>d. Providing condoms (male and female) to workers</p>
10.	24.1 & 47.1	The Site Possession Date shall be notified by the Contract Administrator

11.	28.2	<p>Hourly rate of Fees payable to the Adjudicator is: Kshs 3,000...</p> <p>Types of reimbursable expenses to be paid to the Adjudicator include:</p> <p>a) ...Transport.....</p> <p>b) ...Reports Production.....</p> <p>c) ...Accommodation</p>
12.	28.3	Arbitration will take place at <i>Isiolo county Government offices</i> in accordance with rules and regulations published by The Kenya Government as contained in the Arbitration act
13.	29.1	Appointing Authority for the Adjudicator: <i>The Institution of Engineers of Kenya</i>

B. Time Control

14.	30.1	The Contractor shall Submit a Programme for the Works immediately on delivery of the Letter of Acceptance.
15.	30.3	The period between Programme updates is <i>Monthly</i>
16.	30.3	The amount to be withheld by the Contract Administrator in the case the contractor does not submit an updated programme is: KES 150,000

C. Quality Control

17.	38.1	
-----	------	--

		The Defects Liability Period is 6 Months .
D. Cost Control		
18.	45.7	Minimum Amount of Interim Payment Certificate will be 20% of the contract price
19.	46.1	Final payments will be made after all works are complete and defects rectified to the satisfaction of the supervisor.
20.	47.1(a)	The Site Possession Date shall be notified by the Contract Administrator
21.	50	The contract <i>is not</i> subject to price adjustment in accordance with Clause 50 of the General Conditions of Contract.
22.	51.1	The amount of retention is 10% of value of works of Interim Payment Certificate’.
		Limit of retention will be 10% of contract price.
23.	52.1	The rate of liquidated damages is 0.1 percent of contract price per day
	52.1 62.2 (g)	The maximum amount of liquidated damages is 5% of Contract Price]
24.	53.1	The bonus for early completion is ... Not applicable
25.	54.1	The amount of advance payment shall be 20% of the contract sum payable within 30 days after provision of the Advance payment guarantee
		Recovery of Advance Payment shall be 20% of amount of Interim Payment Certificate.
26.	55.1	The Performance Security shall be 10% of the contract price
E. Finishing the Contract		
27.	61.1	As built drawings for new works shall be supplied by the contractor: Prior to the issuance of the project completion Operating manual for plant and equipment supplied by the contractor shall be supplied by the contractor
28.	61.2	The amount to be withheld by the Contract Administrator in the case the contractor does not submit as built drawings is: .05% of the contract amount The amount to be withheld by the Contract Administrator in the case the contractor does not submit operating manual is KES 150,000
29.	63.1	The percentage to apply to the value of the work not completed, representing the Procuring Entity's additional cost for

SPECIFICATIONS

		completing the Works, is <i>10%</i>
--	--	-------------------------------------

SPECIFICATIONS

INDEX

67. SECTION 1: General...	3
SECTION 2: Earthworks...	20
SECTION 3: Concrete...	33
SECTION 4: Pipe work...	84
SECTION 5: Builders Work...	113
SECTION 6: Boreholes...	129
SECTION 7: Fencing...	139
SECTION 8: Drainage	144
SECTION 9: Steelwork & Miscellaneous...	149
SECTION 10: Painting...	157
SECTION 11: Electrical Installation.....	166
SECTION 12: Diesel Generator.....	172

F.

G. SECTION 1: GENERAL

101	Tender Drawings, Bills of Quantities and Specifications...	5
102	Setting out of the works.....	5
103	Contractor's Working Area/Boundaries of Works.....	6
104	Flagging, Lighting, Watching and Traffic Control... ..	6
105	Restrictions on Use of Roads... ..	6
106	Offices for Contract Administrator's Representative... ..	7
107	Contractor's Offices, Yard, Stores, etc.....	7
108	Accommodation for Workmen... ..	7
109	First Aid Outfits, Medical Treatment and Transport.....	7
110	Water and Electricity Supplies... ..	7
111	Precautions against contamination of the works.....	8
112	Level Datum	8
113	Levels and Dimensions.....	8
114	Survey Equipment and Labour.....	8
115	Order of Construction of Works... ..	8
116	Quality of Materials and Workmanship.....	9
117	Submission of Samples.....	9
118	Responsibility for Ordering Materials and Manufactured Articles and Samples for Testing...9	
119	Testing of Materials.....	9
120	Rejected Materials... ..	10
121	Cutting out existing work... ..	10
122	Existing services.....	10
123	Temporary Removal of Existing services.....	11
124	Permanent Diversion of Existing services... ..	11
125	Permanent Support for Existing Services, etc.....	11
126	Attendance upon other contractor... ..	11
127	Supports to excavations... ..	11
128	Ownership of Excavated and other material... ..	12
129	Care of Boundary Hedges, Walls, Fences and Trees... ..	12
130	Work through private property and serving notices.....	13
131	Compensation for loss of crops etc. in private property... ..	13.
132	Provision of facilities for Contract Administrator's inspection... ..	13
133	Inspections by Contract Administrators During period of Maintenance.....	13
134	Clearing up site	13
135	The lands under the control of the contractor... ..	14
136	Fencing the works... ..	14
137	Correspondence and records to be in English Language.....	14
138	Materials ordered and paid for by the Employer.....	15
139	Testing of Water-Retaining Structures... ..	16
140	Clearing and Sterilizing Water-retaining structure	16
	Water etc. for testing water-retaining structure.....	17
141	Contractor to use special plant if required... ..	17

Use of parts of the works on their completion	17
142 Duty staff.....	17
143 Regulations and site Discipline.....	17
144 Removal of Employees.....	17
145 Record of names and Permanent Address of Employer... ..	18
146 Fire precautions... ..	18
147 Tests on completion.....	18
148 Connection of Existing main	18
149 Responsibility for damage	18
150 Safety precautions to be observed.....	19
151 Opening and reinstatement of surfaces.....	19

GENERAL

101. TENDER DRAWINGS, BILLS OF QUANTITIES AND SPECIFICATION

- 101.1 The Tender Drawings are as listed in Section VI of Volume I and these may be supplemented from time to time by the Contract Administrator during the period of the contract.
- 101.2 The Specifications, Bills of Quantities, and the Tender Drawings are intended to describe and provide for a complete and finished project. They are intended to be co-operative, e.g. all items of work called for by any shall be as binding as if called for by all. The Contractor is to understand that the work herein described shall be complete in every detail, notwithstanding the fact that every item necessarily involved is not particularly mentioned or shown. The Contractor will be held to provide all labour and materials necessary for the completion of the works described and shall not avail himself of any errors or omissions which are manifestly unintentional.
- 101.3 Before commencing any work, the Contractor shall check all drawings, Bills of Quantities and Specifications and report to the Contract Administrator any errors or inconsistencies and shall verify all dimensions given on the drawings
- 101.4 The Specifications are divided into trades and divisions for the distinct purpose of facilitating the work. However, the Contractor will become responsible for furnishing all labour and materials necessary to provide the complete project as contemplated by the drawings and specifications. Any item mentioned under any heading of the Specifications must be supplied even though it is not called for again under the heading for the respective work.
- 101.5 At the award of contract the contractor shall sign one set of drawings and specifications and such signed set of contract documents shall be deposited with the Contract Administrator as an additional evidence of the Contractor’s understanding of the work required.

102 SETTING OUT OF THE WORKS

- 102.1 The Contract Administrator's Representative will if necessary provide the Contractor with basic information supplementary to that shown on the Drawings such as the position of centre-lines and base-lines etc. Such supplementary information may be provided on drawings sketches in writing or indicated on the site.
- 102.2 The contractor shall prepare detailed setting out drawings and data sheets as necessary and submit them to the Contract Administrator's Representative in triplicate for approval. Any modification to the setting out drawings or data sheets required by the Contract Administrator's Representative shall be made by the Contractor and re-submitted for final approval. Approval by the Contract Administrator's Representative shall be signified by the return to the Contractor of one copy duly signed by the former or an authorized member of his staff.
- 102.3 Should it be necessary during setting out or during construction for agreed setting out details to be amended to contractor shall amend the drawings or data sheets or make new ones for approval as required by the Contract Administrator's Representative.
- 102.4 Copies of setting out drawings and data sheets shall be preserved for use by the Contractor in preparing final records and drawings in accordance with the requirements set out elsewhere.
- 102.5 The Contractor shall be before commencing work establish steel datum pegs at all sites which shall be securely concreted in and shall agree with the Contract Administrator the level and co-ordinates of each peg.

103 CONTRACTOR'S WORKING AREA/BOUNDARIES OF WORKS.

- 103.1 The contractor shall make his own arrangements for and pay all costs incurred in the use of such areas of land as he may require for storage and working space for the purpose of the contract.
- 103.2 The employer will provide the land and rights of way for works specified in the contract.
- 103.3 The contractor shall not enter upon or occupy with men tools equipment and materials any land other than land or rights of way provided by the Employer without the written consent of the owner of such additional land or rights of way as he may require in accordance with conditions of contract.

104 FLAGGING LIGHTING WATCHING AND TRAFFIC CONTROL

- 104.1 The Contractor shall be responsible for watching and lighting the works and for the flagging and control of traffic and he shall comply with the requirements of the Employer and police and the competent Authority in these matters.

105 REGISTRATIONS ON USE OF ROADS.

- 105.1 The Contractor shall not run tracked vehicles or tracked plant on any existing works of the Employer or on any public or private road being a metallic or sealed road or on any public or private road being a metallic or sealed road or on any other public or private road without the written approval of the Contract Administrator and the responsible Authority or Owner and subject to such conditions as each may require.
- 105.2 The Contractor shall observe all weight restrictions which apply automatically to the majority of minor roads and tracks in Kenya when such road and tracks are wet and with all other reasonable restrictions which may from time to time be imposed by the Contract Administrator and the responsible Authority or Owner.
- 105.3 Contractor shall not be entitled to additional payment for any additional cost he may incur on account of adverse weather and road conditions, restrictions on the use of the roads delays detours or any other thing which may increase the average haulage distance or journey time or otherwise adversely affect his operations.

106. OFFICE FOR CONTRACT ADMINISTRATOR'S REPRESENTATIVE

- 106.1 The Contractor shall be responsible for the provision of the Contract Administrator's Representative furnished office accommodation for the entire duration of his supervision contract. (A bill item has been included for the costs)

107 CONTRACTOR'S OFFICES, YARDS, STORES, ETC.

- 107.1 The contractor shall provide and maintain at a place to be agreed with the Contract Administrator's Representative an office for the use of his Agent and to which written instructions by the Contract Administrator's Representative can be delivered. Any instructions delivered to such office shall be deemed to have been delivered to the Contractor. This office will be erected before any construction work commences and will be open and attended at all hours when work is in progress.
- 107.2 The Contractor shall make his own arrangements for all yards stores etc. and for all services in connection therewith for the efficient execution of the Contract.
- 107.3 The location of all offices and stores shall be agreed beforehand with the Contract Administrator and shall be such as to avoid obstruction and nuisance to the public and interference with the proper operation of the existing services.

108 ACCOMMODATION FOR WORKMEN

- 108.1 The contractor shall provide at each site sufficient closets or latrines to the satisfaction of the Government Medical Officer. They shall be properly screened and maintained in a clean and sanitary state at all times.

109 FIRST AID OUTFITS MEDICAL TREATMENT AND TRANSPORT

109.1 During the progress of the works the Contractor shall provide and maintain to the satisfaction of the Medical Officer of Health in easily accessible positions on the Site adequate First Aid Outfits to the approval of the Medical Officer of Health and of the Contract Administrator, such outfits to be in charge of an experienced dresser who shall be on duty at the Site during working hours.

110 WATER AND ELECTRICITY SUPPLIES

110.1 The Contractor shall make his own arrangements for water and electricity supplies and shall pay all constructional costs, fees and expenses incurred and for all the water and electricity used.

111. PRECAUTIONS AGAINST CONTAMINATION OF THE WORKS

111.1 The Contractor shall ensure that all his personnel working on the site are medically suitable to be in contact with a public water supply and his personnel shall undergo any necessary medical test at the Contractor's expense to show that they are free from infectious diseases and are not carriers of any such diseases.

111.2 The Contractor shall at all times take every possible precaution against contamination of the works and existing Water Mains. The Contractor shall give strict instructions to all persons employed by him to use the sanitary accommodation provided. Clause 16 of the Conditions of Contract will be rigidly enforced in any case where these instructions are disobeyed.

111.3 Throughout the Contract the Site and all permanent and temporary works shall be kept in a clean tidy and sanitary condition.

112 LEVEL DATUM

112.1 All levels are referred to survey of Kenya datum and the Contractor shall obtain in writing from the Contract Administrator's Representative the location and value of the permanent bench marks to be used.

113. LEVELS AND DIMENSIONS

113.1 The reduced levels shown on the Drawings are believed but not guaranteed to be correct. In the event of any discrepancies between the Drawings and Specification, the Specification shall have precedence over the Drawings. In the event of any discrepancies between Drawings the Contractor shall notify the Contract Administrator in writing who will issue corrections, forthwith.

114. SURVEY EQUIPMENT AND LABOUR

114.1 The Contractor shall maintain the Contract Administrator's Representative survey instruments and other equipment necessary for inspection/checking of Works for the entire duration of the contract (A bill item has been included for the procurement)

114.2 The Contractor shall provide all labour and materials as may be required by the Contract Administrator's Representative for survey work in connection with the works.

115. ORDER OF CONSTRUCTION OF WORKS

115.1 Construction of the Works shall be carried out as directed by the Contract Administrator.

115.2 Following detailed discussions with the Contract Administrator, and before he begins the work, the Contractor shall submit to the Contract Administrator a programme which shall be reviewed and brought up to date at frequent intervals as the work proceeds. The programme shall be adhered to and only varied by permission of the Contract Administrator.

116. QUALITY OF MATERIALS AND WORKMANSHIP

116.1 All materials and workmanship shall be to the approval of the Contract Administrator. In the reading of this Specification the words "to the approval of the Contract Administrator" shall be deemed to be included in the description of all materials or articles incorporated in the Works and in the descriptions of the operation for the due execution of the works.

116.2 Specifications of the British Standards Institution current at the date of tender shall apply for all materials and workmanship unless otherwise directed by the Contract Administrator.

116.3 The words "British Standards Specifications" are hereinafter abbreviated to B.S.

117. SUBMISSION OF SAMPLES

117.1 Before incorporating in the finished work any material or articles which he supplies under the terms of the Contract the Contractor shall submit to the Contract Administrator's Representative for his approval a sample of each respective material or article and such samples shall be delivered to and be kept at his office for reference. All the respective kinds of material and articles used in and upon the Works shall be at least equal in quality to the approved samples. Each and every sample shall be a fair average of the bulk material or of the article which it represents. The Contract Administrators Representative may decide the method by which each sample to be taken from the bulk shall be obtained.

118. RESPONSIBILITY FOR ORDERING MATERIALS AND MANUFACTURED ARTICLES AND SAMPLES FOR TESTING.

118.1 The responsibility for so ordering and delivering materials and manufactured articles and samples that they may be tested sufficiently far in advance of the work as not to delay it shall rest upon the Contractor and he shall not be entitled to any time credit for delays occasioned by his neglect to order sufficiently well in advance or to payment of any costs he may incur as the result thereof.

119 TESTING OF MATERIALS

- 119.1 Tests and inspections will be carried out by the Contract Administrator or by an Inspector to be appointed by him. In such circumstances where the Contract Administrator does not require witnessed tests to be carried out, the Contractor shall furnish test certificates.
- 119.2 The contractor shall provide facilities for the Contract Administrator or his Agent to inspect examine and test all materials and workmanship. If the materials are manufactured on premises other than those of the Contractor, he shall obtain from the manufacturer similar facilities.
- 119.3 The Contractor shall give two weeks' notice to the Contract Administrator of the place or places at which the materials are to be manufactured and as to when testing will be in progress and shall ascertain before manufacture commences whether the Contract Administrator wishes to attend or send his Agent for the purposes of witnessing manufacture, inspecting, examining, or testing.

120 REJECTED MATERIALS

- 120.1 Should any materials or manufactured articles be brought on to the Site of the Works which are in the judgment of the Contract Administrator unsound or of inferior quality or in any way unsuited for the work in which it is proposed to employ them, such materials or manufactured articles shall not be used upon the Works but shall forthwith be removed from the Site of the Works all at the Contractor's expense and in each case as the Contract Administrator and/or Contract Administrator's Representative shall decide and direct.

121 CUTTING OUT EXISTING WORK

- 121.1 Where existing work is to be cut, the Contractor shall ensure that the cutting out is done in such manner as not to cause permanent damage to the surrounding structure. Before commencing to cut out any work, the Contractor shall submit to the Contract Administrator the method he proposes to use and no such work will be permitted until the Contract Administrator's written approval has been obtained.
- 121.2 Notwithstanding the giving of the Contract Administrator's approval, the Contractor shall be liable for making good at his own expense any damage arising from such work of cutting out.

122 EXISTING SERVICES

- 122.1 The Contractor shall take every precaution to ensure that all existing services pipes cables drainage and irrigation ditches and the like are located supported and safeguarded from damage even though they may not be in the line of excavation but near to it. Any damage caused to any such services pipes culverts cables drainage and irrigation ditches and the like attributable to the Contractor's operations or to his negligence shall be made good by or for

the Contractor at his own expense or the satisfaction of the Contract Administrator and of the owner or responsible Authority.

- 122.2 In the event of the owner or responsible Authority electing to repair such damage the Contractor shall pay the cost of his or their so doing the work. Should the Contractor fail to pay the cost of the said work within a reasonable period of the account being presented the Employer reserves the right to settle the account and deduct the sum paid by him from moneys due or which may become due to the Contractor.

123 TEMPORARY REMOVAL OF EXISTING SERVICES

- 123.1 If it should become necessary for the proper execution of the work temporarily to remove or divert any existing pipe sewer field-drain cable drainage or irrigation ditch or other service the Contractor shall obtain permission from the competent

Authority or Owner and shall carry out the work at his own expense in a manner and at times to be approved by such Authority or owner and shall subsequently reinstate the work to the satisfaction of such Authority or Owner. In the event of the Owner of responsible Authority electing to arrange for the temporary removal of an existing service the Contractor shall pay the cost of his or their doing the work. Should the Contractor fail to pay the cost of the said work within a reasonable period of the account being presented the Employer reserves the right to settle the account and deduct the sum paid by him from moneys due or which may become due to the Contractor.

- 123.2 The Contractor's attention is particularly drawn to the requirement to maintain drainage and irrigation ditches in order to avoid any interruption of flow of water therein to the satisfaction of the Contract Administrator Owner or competent Authority and the Contractor shall be deemed to have included in his rates and prices for all temporary works so required.

124 PERMANENT DIVERSION OF EXISTING SERVICES

- 124.1 If in the opinion of the Contract Administrator and/or of the competent Authority or owner it should become necessary permanently to remove or re-align any existing pipe sewer field-drain cable ditch or other service the Contractor shall obtain permission where necessary from the competent Authority or Owner and shall carry out and complete the work to the satisfaction of the Contract Administrator and such Authority or Owner. Payment for such additional work will be made in accordance with the tendered rates and/or the schedule for day work contained in the Bill of Quantities as the Contract Administrator will determine provided always that the necessity for such permanent diversion has not arisen due to the fault of the contractor.

- 124.2 In the event of the Owner or responsible Authority electing to arrange for the permanent diversion of an existing service due to the fault of the contractor doing the work. Should the Contractor fail to pay the cost of the said work within a reasonable period of the account being presented the Employer reserves the right to settle the account and deduct the sum paid by him from monies due or which may become due to the Contractor.

125 PERMANENT SUPPORT FOR EXISTING SERVICES, ETC.

- 125.1 If in the opinion of the Contract Administrator and/or the competent Authority or owner it should become necessary to provide permanent support for any existing pipe sewer cable structure or other thing disturbed exposed or injured during or after the execution of the works the Contractor shall carry out promptly such additional works as the Contract Administrator may require to provide such permanent support. Payment for such additional work will be made in accordance with the tendered rates and/or the schedule for Day work contained in the Bill of Quantities as the Contract Administrator will determine provided always that the necessity for such permanent support has not arisen due to the fault of the Contractor.

126 ATTENDANCE UPON OTHER CONTRACTORS

- 126.1 When an item is included in the Bill of Quantities for attendance, such attendance shall in addition to the requirements of the conditions of contract include all reasonable and customary conveniences apparatus plant and labour in attendance.

127 SUPPORT TO EXCAVATIONS

- 127.1 Payment for timber and other supports left in excavations will be made only for those supports ordered to be left in for any purpose by the Contract Administrator. Supports so left in will be paid for at the rates entered in the Bill of Quantities.

128 OWNERSHIP OF EXCAVATED AND OTHER MATERIAL

- 128.1 All material of any kind whatsoever including growing matter removed or cut down as part of the works shall remain the property of the Employer or the owner of the land through under or over which the works are carried out. The disposal of such material belonging to the Employer shall be at the discretion of the Contract Administrator who will instruct the Contractor in all matters of its use and/or removal from the site.

129 CARE OF BOUNDARY HEDGES, WALLS, FENCES AND TREES

- 129.1 The Contractor shall not cut through or remove any section of any boundary, hedge, wall, or fence without the prior approval of the Contract Administrator's Representative who will determine the limits of such cutting or removal.
- 129.2 Approval for the cutting or removal of boundary hedges walls and fences will normally be limited to those crossing the route of mains and pipelines and the contractor shall so conduct his operations as to minimize the extent of such cutting through or removal.

129.3 In the case of boundary hedges walls and fences being part of enclosed paddocks or grazing areas the Contractor shall provide erect maintain and remove on completion of all work adequate temporary fencing or shall by other means ensure that animals and other livestock cannot stray from the previously enclosed paddocks or grazing areas.

129.4 The Contractor shall repair and reinstate in a manner similar to the original or by other approved means any hedging wall or fence which he may have cut through or remove with or without the approval of the Contract Administrator's Representative or damaged during his operations and all such repairs and reinstatement shall be the contractor's sole liability and shall be carried out to the satisfaction of the Contract Administrator and the responsible Authority or owner.

129.5 The Contractor shall not cut down grub up or remove any tree without the prior permission of the Contract Administrator.

130 WORK THROUGH PRIVATE PROPERTY AND SERVING OF NOTICES

130.1 Where the work is to be executed in private land the Employer will be responsible for negotiating and obtaining rights of way and the serving of all notices as may be required upon the Owners and/or Occupiers of the land and it shall be the obligation of the Contractor to keep the Employer and the Contract Administrator fully informed concerning the rate of contract progress and of his intention to enter and begin work within any way leave as required by Clause 201 and 202 of this Specification.

131 COMPENSATION FOR LOSS OF CROPS ETC. IN PRIVATE PROPERTY

131.1 The attention of the Contractor is drawn to Clause 11 of the conditions of contract and with reference to sub-clause 11(1) of the clause the description "loss of or damage to property" shall mean crops including trees, shrubs and hedges within the boundaries of the lands and rights of way defined in this Specification except such individual trees shrubs and hedges which the Contract Administrator may require to be preserved in accordance with Clause 292 of this Specification.

132 PROVISION OF FACILITIES FOR CONTRACT ADMINISTRATOR'S INSPECTIONS

132.1 The Contractor shall provide the necessary equipment access and labour to enable the Contract Administrator and/or the Contract Administrator's Representative to conveniently carry out such inspections as they may deem necessary at all times during the currency of the contract.

INSPECTIONS BY CONTRACT ADMINISTRATOR DURING PERIOD OF MAINTENANCE

132.2 The Contract Administrator will give the Contractor due notice of his intention to carry out any inspections during the period of Maintenance and the Contractor shall thereupon arrange

for a responsible Representative to be present at the times and dates named by the Contract Administrator. This Representative shall render all necessary assistance and take note of all matters and things to which his attention is directed by the Contract Administrator.

134 CLEARING UP SITE

- 134.1 During the progress of the works the contractor shall at reasonable intervals or when required by the Contract Administrator's Representative gather and remove rubbish and surplus materials from the site.
- 134.2 On completion of the works the site of all permanent and temporary works in connection with the contract shall be carefully cleared up and everything shall be handed over to the Employer in a neat and clean condition.
- 134.3 All rubbish roots undergrowth and the like cleared from the works must be burnt or removed completely from the site and disposed of by other means to the satisfaction of the Contract Administrator and the Contractor shall make his own arrangements for all such disposal.
- 134.4 All surplus materials and manufactured articles supplied by the contractor shall if not accepted or purchased by the Employer be removed from the site and disposed of by the contractor.

135 THE LANDS UNDER THE CONTROL OF THE CONTRACTOR

- 135.1 The Contractor shall attend to all operations carried out on the lands under his control and utilize them only for the purpose of construction of the works and to the lands responsible for any damage to the lands responsible for any damage to the lands and to the lands adjacent. Before starting any work the Contractor shall ascertain the boundaries of the lands coming under his control.

136 FENCING THE WORKS

- 136.1 The Contractor shall fence the works in a manner sufficient for the protection of the public and of livestock and property to whomsoever it may belong during the progress of the works and shall satisfy the Employer and the Contract Administrator or his Representative in this respect.
- 136.2 Temporary fencing shall prevent the straying of livestock and reasonable access to lands and premises must be provided.
- 136.3 The Contractor shall erect and maintain guard-rails around all trenches and other open excavations in a manner sufficient to provide safety for pedestrians and vehicles at all time.
- 136.4 Temporary bridges shall be provided across trenches to maintain reasonable access for pedestrians and vehicles to land and property on either side of the trench.

137 CORRESPONDENCE AND RECORDS TO BE IN THE ENGLISH LANGUAGE

- 137.1 All correspondence between the contractor and the Contract Administrator or the Contract Administrator's staff shall be in the English language.
- 137.2 All books, time sheet records, notes, drawings, documents shall be in the English Language, or, if the original documents are in another language, a certified translation in English shall be submitted to the Contract Administrator or Contract Administrator's Representative.

138 MATERIALS ORDERED AND PAID FOR BY THE EMPLOYER

- 138.1 The Employer will deliver to the Contractor at the specified places the materials detailed (but not by way of limitation) in the Appendix to the Bill of Quantities and any other materials of which the Contract Administrator may from time to time give particulars to the contractor. Payment for all such materials delivered to those places and store areas has been or will be made by the Employer to the several manufacturers forwarding agents and shipping companies and the Contractor will not be allowed commission on any such payments.
- 138.2 The Contractor shall take delivery of all materials without delay upon receipt of instructions from the Contract Administrator's Representative giving details of the materials and the places at which delivery is to be taken.
- 138.3 The Employer will make every endeavor promptly to supply any materials which he may undertake to supply in accordance with the Conditions but he will accept no responsibility for loss delay or inconvenience suffered by the Contractor should such materials not be available and/or delay occur in the supply of such materials and plant.
- 138.4 The Contractor shall examine the materials before taking delivery and shall report any damage defect or deficiency to the Contract Administrator's Representative immediately.

Any damage defect or deficiency so reported or which arises after the contractor has taken delivery and could not reasonably have been detected by normal methods of inspection shall be repaired or made good at the expense of the Employer provided always the Contract Administrator is satisfied that such damage defect or deficiency has not been caused by negligence on the part of the contractor.

- 138.5 Subject to the above provisions whilst taking delivery of and after taking delivery of all materials by the Employer and Contractor shall be solely responsible for any loss, damage, defect or deficiency however arising in connection therewith and he shall forthwith make good such loss, damage, defect or deficiency at his own expense.
- 138.6 After taking delivery of the materials the Contractor shall transport them without delay to his own store on the site of the works or elsewhere. The contractor will be held solely responsible for any claim against the Employer and any delay brought about by the Contractor's failure to take delivery immediately he is instructed to do so and the settlement of any such claims shall be at the Contractor's sole expense.
- 138.7 In pricing the items in the Bill of Quantities for "Take delivery" the Contractor shall include (but not by way of limitation) for the following services and supplies:-

- (a) Accept, unpack, physically inspect, and test as may be necessary, re-pack as required report discrepancies and breakages, cart to storage compound and/or stores building and conduct all insurances claims.
- (b) Store the materials and plant and maintain a Stores Ledger recording in full detail both the receipt and disposal of all items.
- (c) Guard and insure all such material and plant against all loss or damage.

138.8 Where materials are supplied by the Employer the quantity incorporated in the Works will be checked against the quantity supplied. The Contractor shall at his own expense return all surplus material to the Employer's store and make good any deficiencies. In checking pipes an allowance of not more than one per cent of the measured quantity used will be made to cover cutting to waste except in special circumstances which shall be decided by the Contract Administrator.

139 TESTING OF WATER-RETAINING STRUCTURES

139.1 All water-retaining structures shall be tested for water tightness on completion in the following manner. The structure shall be filled with clean water in stages and held at each water level for such time as the Contract Administrator may require. Should any dampness or leakage occur at any stage the water shall be drawn off and the defects remedied to the satisfaction of the Contract Administrator. The procedure shall be continued and finally the structure shall be allowed to remain full for seven days. Should any damages or leakages or other defects occur they shall be made good to the satisfaction of the Contract Administrator and the structure re-tested until the water tightness is approved by the Contract Administrator.

139.2 The Contractor shall provide a hook gauge to measure variations in water level during the tests.

139.3 The testing shall be carried out before excavations are backfilled and embankments placed.

140. CLEANSING AND STERILIZING WATER-RETAINING STRUCTURE

140.1 The inside of all potable water-retaining structure and all interior pipe work and fittings shall be thoroughly cleaned and washed after the water tightness test has been approved by the Contract Administrator to remove all contamination and the water from these operations shall be removed by squeegees and drained away.

140.2 The structure shall then be filled to overflow level with clean water clean water containing 20 parts per million of chlorine and left for a period of at least 24 hours. The chlorinated water shall then be drained away and the structure refilled with clean water from which samples shall be taken for analysis to the instruction of the Contract Administrator. If any of the results of the analyses are unsatisfactory when compared with those of the control sample of the supply water the sterilizing process shall be repeated until the results of the test are satisfactory.

140.3 The costs of the initial sampling analysis and preparing reports on the bacteriological quality of the water shall be borne by the Employer but should the initial reports be unsatisfactory the costs of any subsequent sampling analyses preparing reports shall be borne by the Contractor.

141 WATER ETC. FOR TESTING WATER-RETAINING STRUCTURES

141.1 The Contractor shall make available all water required for the testing of water-retaining structures. The Employer may allow the Contractor to draw water for testing from the existing water supply at the price pertaining at the time.

141.2 The Contractor shall be solely responsible for the provision of all labour materials and other things necessary for testing water-retaining structures.

141.3 The Contractor shall be responsible for making all arrangements necessary for obtaining all water required for testing water-retaining structures.

142 CONTRACTOR TO USE SPECIAL PLANT IF REQUIRED

142.1 The Contractor shall if the Contract Administrator so requires supply and use such special plant and tools in executing the work as the Contract Administrator may direct.

143 USE OF PARTS OF THE WORKS ON THEIR COMPLETION

143.1 Should the Employer so desire he shall have full power to use and put into active operation any or all sections or parts of the works directly they are finished. Such action shall not however relieve the Contractor of his obligations with regard to maintenance.

144 DUTY STAFF

144.1 At least one responsible senior representative shall be on the site and immediately available at all times during normal working hours. To such representative shall be delegated full authority to confer with the Contract Administrator's Representative or his staff and to take all steps and to issue all those instructions which may be required in an emergency to ensure the safety of all personnel of the works and of all the Employer's and other property on the Site and in the immediate vicinity thereof. The Contract Administrator's Representative may from time to time at his discretion after taking into consideration all the prevailing conditions allow some relaxation of this clause but such relaxation shall be made only with his written permission and subject to any special conditions which he may then require.

145 REGULATIONS AND SITE DISCIPLINE

145.1 The Contractor shall obey all police health and municipal regulations all other regulation which may from time to time require his observance and he shall instruct his agents servants and other employees to obey such regulations. The Contractor shall be responsible for keeping discipline on the Site and shall permanently remove from site within 24 hours from receipt of written instructions by the Contract Administrator to that affect any servant laborer or other employee who neglects to observe the regulations or who refuses to carry out

instructions given to him by the Contractor on the representation of any responsible representative of the Employer.

146 REMOVAL OF EMPLOYEES

146.1 The contractor shall permanently remove from site any person guilty of attempted dishonesty to the Employer or of disobedience of the regulations aforesaid or of bad behavior of who causes or attempts to cause trouble and unrest among the labour force.

147 RECORD OF NAMES AND PERMANENT ADDRESSES OF EMPLOYEES

147.1 The Contractor shall keep a full record giving the names and permanent addresses of all his employees and holds this record for the inspection of the Contract Administrator.

148 FIRE PRECAUTIONS

148.1 The Contractor shall provide at the Site adequate audible means of giving the alarm in the event of an outbreak of fire and shall make arrangements which may be necessary for the sounding of such an alarm. The Contractor shall take all precautions against fire and he shall provide firefighting appliances labour, pangas, beaters, axes etcetera as may be necessary for the isolation and extinguishing of fires with the utmost expediency.

149 TESTS ON COMPLETION

149.1 On commissioning of the works the contractor shall have on site personnel to ensure that all the plant is working satisfactorily. The personnel shall be on site for a minimum period of 7 days or for such time as is required to determine that the equipment is operating to the satisfaction of the Contract Administrator.

150 CONNECTION INTO EXISTING MAIN

150.1 Connection into existing mains will be carried out at times acceptable to the Employer such that any inconvenience to the public is kept to a minimum. This may require night or Sunday working and the contractor must allow for this in his rates. The contractor shall notify the Contract Administrator at least seven days before the day on which the particular connection is proposed. The Contract Administrator will make any necessary arrangement for the limited shut down of the mains, provided that times proposed are acceptable.

151 RESPONSIBILITY FOR DAMAGE

151.1 The Contractor shall be fully responsible for any damage which may be done by himself or his employees to site buildings, works services such as electricity, water, gas, pipelines, or apparatus. Such damage must be made good to the entire satisfaction of the Contract Administrator within a reasonable period of time specified in writing by the Contract Administrator.

151.2 The Contractor shall be fully responsible for and take every reasonable precaution to protect any section of the contract works against loss or damage from any cause.

152 SAFETY PRECAUTIONS TO BE OBSERVED

- 152.1 The Contractor shall be responsible for the safety of his own staff and his sub-contractors staff whilst employed on the site.
- 152.2 The Contractor shall see that only safe working practices are used, and that only proper and safe equipment such as step ladders, ladders, scaffolding, ropes, and lifting equipment are in use on the site. The Contractor shall ensure that his staff are suitably instructed to use only safe working methods and safe appliances during the receipt, unloading, handling into store and transmission to site, erection and installation, testing and commissioning, the equipment, materials and installation forming the requirements of this contract.
- 152.3 The Contract Administrator will require cessation of any working practice which in the Contract Administrator's opinion is not safe and the removal of any equipment which has not been certified as safe by an appropriate authority.

153 OPENING AND REINSTATEMENT OF SURFACES

- 153.1 The Contractor shall ascertain and observe the current regulations of the Highway Authority and the requirements of any other body public or private person in, on, under, over or through whose land the works are to be carried out for the opening and reinstatement of surfaces and it will be deemed that he has ascertained all charges and requirements connected therewith and has made full allowance in his prices therefore.
- 153.2 All surfaces of roads fields open spaces paths courtyards gardens verges and other places whether public or private which are affected by the operations of the contractor are to be reinstated by him both temporarily and permanently unless in the case of surfaces in the control of the Highway Authority or a public body such Authority or body shall elect to do the permanent reinstatement themselves when the Contractor shall do the Temporary reinstatement only.

SECTION 2

H. EARTHWORKS

201	Conditions of Site.....	21
202	Site Clearance.....	21
203	Ground Levels... ..	22
204	Trial Hole	22
205	Excavation Generally.....	22
206	Excavation in Excess... ..	23
207	Mechanical Excavation... ..	23
208	Restoration of Borrow Areas Spoil Tips and Quarries... ..	24
209	Headings	24
210	Excavation for Foundations, Thrust and Anchor Blocks.....	24
211	Excavation in Rock.....	25
212	Keeping Rock Faces Dry	25
213	Cleaning Rock Surfaces... ..	25
214	Explosives... ..	26
215	Excavated Materials suitable for re-use.....	26
216	Refilling of excavations	26
217	Hard Filling... ..	27
218	Refilling of Pipe Trenches... ..	27
219	Making good subsidence after re-filling... ..	27
220	Removal of Timber from Excavations.....	28
221	Reinstatement of Surfaces.....	28
222	Forming Banks and Filled Areas... ..	28
223	Planting	29
224	Disposal of Surplus Excavated Material... ..	29
225	Free Draining Fill... ..	30
226	Graded Gravel for Drains.....	30
227	Rock Pitching... ..	31
228	Formation of Footpaths.....	31
229	Concrete Paving Slab Lining to Ponds... ..	31
230	Reinstatement of Trench Surfaces in Roads... ..	31

201 CONDITION OF SITE

- 201.1 Before carrying out any work on any site the site shall be inspected in conjunction with the Contract Administrator's Representative to establish its general condition which shall be agreed and recorded in writing.
- 201.2 Details recorded shall include the location of all boundary and survey beacons the condition of buildings surfaces terracing (if any) ditches watercourses roads tracks fences and other information relating to the site and elsewhere which may be affected by the Contractor's operations.
- 201.3 In the case of way leaves for mains and pipelines the boundaries of the way leaves will be defined by the Employer and the contractor shall provide erect and maintain in position from commencement to final completion of all work and all reinstatement in every section substantial timber stakes or similar approved markers not less than 1.5m high indicating the position of every beacon at 100m or such other intervals as the Contract Administrator's Representative may require. Payment for this work will be made at the tendered rate.
- 201.4 In the event of any boundary or survey beacon being disturbed or displaced as a result of the Contractor's operations the Contractor shall forthwith at his own expense replace the beacon and shall employ the services of an approved licensed survey for this purpose.

202 SITE CLEARANCE

- 202.1 Before beginning excavation or other work on any site the areas to be occupied by the permanent works shall be cleared of all trees stumps bushes and other vegetation and all roots shall be grubbed out. The felling and disposal of trees other than coffee trees exceeding 1000mm. girth at a height of 1.0m above ground level shall be measured separately and paid for in accordance with the tendered rates.
- 202.2 All debris shall be burnt or removed and disposed of by other means to the satisfaction of the Contract Administrator.
- 202.3 The limits of the areas to be cleared shall be as indicated on the drawings or as will be defined by the Contract Administrator.
- 202.4 In the case of way leaves for cables, mains, pipelines and the like the area to be cleared shall extend over the full width of the way leaves but the Contractor shall preserve as far as practicable all grass and other vegetation outside the limits of trenches and permanent works within the way leaves and shall not unnecessarily destroy crops, coffee trees and the like the removal of which is not essential to his operations.

- 202.5 The Contract Administrator may require that individual trees shrubs and hedges are to be preserved and the Contractor shall take all necessary precautions to prevent their damage. In the case of trees etc. which the Contract Administrator requires to be preserved the cutting or grubbing out and disposal of roots encountered within the net dimensions of any excavation or the minimum required width of any trench shall be paid for in accordance with the Schedule for day work contained in the Bill of quantities.
- 202.6 Before beginning clearance within any way leaves the Contractor shall give seven days written notice of his intention to the Contract Administrator who will determine the extent and limits of such clearance having regard to the Contractor's requirements the rate of Contract progress the reasonable wishes of owners and occupiers weather conditions and other factors which in the opinion of the Contract Administrator may affect or be affected by the Contractor's proposals.
- 202.7 The Contractor shall take particular care at all times to prevent erosion on every site and elsewhere on land which may be affected by his operations and the Contract Administrator may impose such reasonable limitations and restrictions upon the method of clearance and upon the timing and season of the year when clearance is carried out as the circumstances seem to him to warrant.

203 GROUND LEVELS

- 203.1 Following the completion of site clearance and before the commencement of any earthworks the sites shall be surveyed in conjunction with the Contract Administrator's Representative to establish existing ground levels and these agreed ground levels shall form the basis for the calculation of quantities of any subsequent excavation and filling.

204 TRIAL HOLES

- 204.1 The contractor shall excavate refill and restore in advance of his programme all such trial holes as he may require for the location of water and other mains cables rock etc. The cost of these trial holes shall be included in his excavation rates.

205 EXCAVATION GENERALLY

- 205.1 Excavation shall be made in open cutting unless tunneling or heading is specified or approved by the Contract Administrator and shall be taken out as nearly as possible to exact dimensions and levels so that the minimum of infilling will afterwards be necessary.
- 205.2 It shall be the Contractor's responsibility at all times to ensure the stability and safety of excavations and the Contractor shall take all measures necessary to ensure that no collapse or subsidence occurs.
- 205.3 The sides of all excavations shall be kept true and shall where necessary be adequately supported by means of timber, steel or other type struts wallings poling

boards sheeting bracing and the like. All supports shall be of sound design and construction and shall be sufficiently watertight to permit excavation concreting and other work to be completed satisfactorily.

- 205.4 Excavations shall be kept free from water and it shall be the Contractor's responsibility to construct and maintain temporary diversions and drainage works and to carry out pumping and to take all measures necessary to comply with this requirement.
- 205.5 In the event of soft or otherwise unsuitable ground being encountered at formation level in any excavation the Contractor shall forthwith inform the Contract Administrator's Representative and shall excavate to such extra depth and refill with compacted granular or other approved fill or Class '10' concrete as the Contract Administrator may require. Payment for such additional excavation and additional refilling will be made at the tendered rates provided always that the formation has not become soft or otherwise unsuitable due to the fault of the Contractor. The requirements of this paragraph shall apply also to the side face of any excavation with which concrete or other work will be in contact except that in the case of a side face the Contract Administrator may alternatively require that the net dimensions of the concrete or work shall be increased.

206 EXCAVATION IN EXCESS

- 206.1 If any part of any excavation is in error excavated deeper and/or wider than is required the extra depth and/or width shall be filled with Class 10 concrete or compacted granular or other approved fill to the original formation level and/or dimensions at the Contractor's expense as the Contract Administrator may require.

207 MECHANICAL EXCAVATION

- 207.1 A mechanical excavator shall be employed by the Contractor only if the subsoil is suitable and will allow the timbering of the trenches or other excavations to be kept sufficiently close up to ensure that no slips falls or disturbance of the ground take place or there are no pipes cables mains or other services or property which may be disturbed or damaged by its use.
- 207.2 When mechanical excavations are used a sufficient depth of materials shall be left over the bottom of the excavations to ensure that the ground at formation level is not damaged or disturbed in any way. The excavation shall then be completed to formation level by hand.

208 RESTORATION OF BORROW AREAS SPOIL TIPS AND QUARRIES

- 208.1 Any quarries or other borrow areas developed by the Contractor for the soil purpose of the works shall be finished to safe and fair slopes to the approval of the Contract Administrator. Where directed by the Contract Administrator areas shall be re-soiled with at least 100 mm of topsoil and grassed. The cost of such work shall be included in the Contractor's prices.

209 HEADINGS

- 209.1 The excavations for all pipelines pumping mains and works mains are to be made in open-cutting unless the permission of the Contract Administrator for the ground to be tunneled is given in writing or a heading is shown on the Drawings. If the Contractor applies to the Contract Administrator for permission to use headings and if this is given there shall be no additional cost whatsoever to the Employer.
- 209.2 Where a heading is specified or shown on the drawings or permitted to be used it shall be constructed to the approval of the Contract Administrator and to dimensions which will permit a proper inspection to be made. The heading shall be properly and securely timbered. The pipe shall be laid on a minimum thickness of 150mm of Class '15' concrete.

After the pipe has been laid, jointed and tested the heading shall be filled in short lengths not exceeding 1 metre with Class '15' or '10' displacer concrete as directed. Great care shall be taken to ensure that the heading is completely filled with concrete and hard filling shall be rammed into the concrete at the crown of the heading. Special precautions shall be taken to prevent a slump in the concrete and to ensure that no slips or falls of the heading or in the ground above or in the shafts can take place. The Contractor shall allow for leaving in all timbering. The Contractor shall be responsible for the proper restoration of any road surfaces, pipes, cables or other things or property that may be damaged.

210 EXCAVATION FOR FOUNDATIONS THRUST AND ANCHOR BLOCKS

- 210.1 Excavations for foundations and for thrust and anchor blocks shall be to such depths as the Contract Administrator may direct and no concrete or other material shall be placed until the formation has been examined and approved. Due notice shall be given to the Contract Administrator's Representative to enable him to examine the formation well in advance.
- 210.2 The Contract Administrator may direct that a layer of excavation of not less than 75mm thickness shall be left undisturbed and subsequently taken out by hand immediately before concrete or other material is placed. Similarly where concrete or other material is to be placed in contact with the side face of an excavation the Contract Administrator may direct that the final 75mm thickness of the excavation to that face shall be left undisturbed and subsequently taken out neatly to profile by hand.
- 210.3 Areas of excavation which are to receive a layer of site concrete as a screed under the structural concrete shall be covered with the screed immediately the excavation has been completed.
- 210.4 If in the opinion of the Contract Administrator due to the fault of the Contractor the ground becomes weathered prior to the placing of concrete or other material the

Contractor shall excavate the weathered soil and replace it with Class '10' concrete to the original formation level at his own expense.

211 EXCAVATION IN ROCK

211.1 Rock will be defined as follows for the purposes of payment:-

Solid ledge or bed rock which cannot be removed without systematic drilling and blasting or barring and wedging, conglomerate deposits which are firmly cemented that they possess the characteristics of solid rock and which cannot be removed without systematic drilling and blasting or barring and wedging; boulders exceeding 0.3 cubic metres in volume.

211.2 No excavation in materials which can be excavated by the use of pick and shovel will be considered or paid for as rock excavation

211.3 The breaking of concrete or road surface or road base will not be considered or paid for as rock excavation.

211.4 The Contract Administrator's decision as to the necessity or otherwise of rock excavating methods or appliances shall be final.

212 KEEPING ROCK FACES DRY

212.1 The contractor shall keep free of running water pools the surfaces of rock upon or against which concrete is to be deposited and no concrete shall be placed until surfaces of the rock are properly drained. Special precautions are to be taken to prevent running water from washing out cement or concrete while it is setting or in any other way from injuring the Works. Drains and pipes shall be provided in or behind concrete as may be necessary for the temporary conveyance of water and shall afterwards be grouted up and such laying and grouting shall be at the Contractor's cost.

213 CLEANING ROCK SURFACES

213.1 The faces and surfaces of all rock against which concrete is to be placed shall after being excavated to the required limits be properly cleaned and left free from all dust loose pieces of rock mud dirt and other loose material and they shall be perfectly clean when the concrete is deposited.

214 EXPLOSIVES

214.1 Should the Contractor wish to transport or use explosives on or in connection with the Works he shall comply with the Explosives Laws of Kenya. The Contractor shall provide a special proper store for explosives in accordance with local regulations and shall provide experienced men for handling explosives to the satisfaction of the Contract Administrator and the Authorities concerned.

214.2 Blasting shall only be carried out on these sections of the Works for which permission in writing shall have been given by the Contract Administrator's Representative and shall be restricted to such hours and conditions as he may prescribe. Such permission shall not be withheld nor such hours and conditions imposed unreasonably.

214.3 The greatest care shall be taken in the use of explosives the charges being so placed and of such amount as in no way to weaken existing structures or the foundations or ground adjacent to the existing and proposed works. The Contractor shall take all necessary precautions to prevent loss injury or accident to persons or property and shall be entirely liable for any accident or damage that may result from the use of explosive.

215 EXCAVATED MATERIALS SUITABLE FOR RE-USE

215.1 In so far as they may be suitable and comply with the specification materials arising from excavations may be used in the works.

215.2 The Contractor in excavating shall ensure that all materials suitable for re-use are kept separate and set aside and protected as necessary to prevent loss or deterioration.

215.3 The materials forming the surface and foundations of roads tracks and footways shall when excavated and if required for further use be carefully separated all hard materials being kept free from soil or other excavated materials.

215.4 Paving slabs bricks and similar surfaces shall be carefully removed and stacked. Prior to the commencement of excavation the number of badly broken and unusable paving slabs bricks etc. on the line or the excavation shall be agreed with the Contract Administrator's Representative and only the cost of replacing these shall be paid as an extra to the Contractor.

215.5 In verges and other grass surfaces the grass and top soil shall be stripped and separately stacked.

215.6 In particular the Contractor in excavating shall ensure that all granular or other approved material suitable for filling around and over pipes shall be kept separate and re-used for this purpose and the Contractor shall not be entitled to payment for screening or transport as provided for in Clause 218 of this specification if this requirement is not complied with

216 REFILLING OF EXCAVATIONS

216.1 All refilling of excavations and trenches shall be thoroughly compacted in layers not exceeding 150mm. compacted thickness and by means which will not damage the works.

217 HARD FILLING

- 217.1 Hard filling shall consist of approved clean mixed ballast, broken stone, and/or concrete. All the materials shall be broken so as to pass through 75 mm. internal diameter rings and be evenly graded between that size and 3 mm. mesh size thereby enabling them when thoroughly compacted to form a hard solid mass. Filling shall be free from all earth clay vegetable or other organic matter shall contain no broken plaster lime mortar or other rubbish. It shall be laid in 300mm. layers each layer being properly spread and thoroughly compacted with rollers and/or rammers.

218 REFILLING OF PIPE TRENCHES

- 218.1 Filling around and for 300mm over the top of the pipe shall be completed by hand using approved hand rammers and suitable material obtained from excavations. Materials for such refilling shall be free from stones greater than 25mm. and to the approval of the Contract Administrator.
- 218.2 If the quantity of suitable material is insufficient the Contractor shall either screen the excavated soil to exclude stones and other materials likely to damage the pipes or transport suitable material from other excavations or borrow pits as the Contract Administrator may require. The cost of such work shall be paid for at tendered rates provided always that the Contractor has complied with the requirements of Clause 215 of this specification
- 218.3 Filling around and for 300 mm over the top of pipes shall be carried out with the utmost care special attention being paid to joint holes so as to obtain the greatest possible compactness and solidity.
- 218.4 The remainder of the trench may be filled in with selected approved filling by hand or alternatively mechanical equipment if approved by the Contract Administrator. Hand rammers and mechanical equipment shall be to the approval of the Contract Administrator.

219 MAKING GOOD SUBSIDENCES AFTER REFILLING

- 219.1 All refilling whether over foundations or in pipe trenches shall be thoroughly compacted by ramming and any subsidence due to consolidation shall be made up by the Contractor at his own expense with extra compacted material. Should subsidence occur after any temporary or permanent surface reinstatement has been completed the surface reinstatement shall first be removed the hollows made up and then the surface reinstatement re-laid.

220 REMOVAL OF TIMBER FROM EXCAVATIONS

- 220.1 Timbering shall be removed from the excavations before or during the process of refilling except in so far as this removal of timber would be likely to cause damage to adjacent property structures or structure foundations in which event the Contractor shall leave in the excavations which event the Contractor shall leave in the excavations such timber as he considers necessary to prevent damage the proper

repair or which the Contractor shall be solely responsible for in the event of any such damage occurring.

- 220.2 Except as provided for below no extra payment will be made for timber left in excavations and the Contractor will be deemed to have allowed for this contingency in pricing his Tender. The Contract Administrator will however certify for payment in respect of such timber does not arise from any negligence of the Contractor.

221 REINSTATEMENT OF SURFACES

- 221.1 All surfaces whether public or private who are affected by the works shall be reinstated temporarily by the Contractor in the first instance and in due course when the ground has consolidated fully he shall reinstate the surfaces permanently.
- 221.2 The temporary reinstatement and maintenance and permanent reinstatement and maintenance of all surfaces of roads streets paths fields, verges gardens and any other surfaces which have been affected by the operations of the Contractor shall be his sole liability and shall be carried out to the satisfaction of the Contract Administrator and of the responsible authority.
- 221.3 Temporary reinstatement shall be carried out immediately the trenches are refilled.
- 221.4 Permanent reinstatement shall not be carried out until the ground has consolidated completely and the Contractor shall apply to the Contract Administrator for permission to carry out this work in the event of further settlement occurring after the completion of the permanent reinstatement and during the currency of the Contract the Contractor shall forthwith make good the reinstatement to the approval of the Contract Administrator or responsible authority.
- 221.5 For the purposes of temporary and permanent reinstatement roads tracks and footpaths the surface width of trenches shall be increased by 150mm on each side of the trench for a depth of 75mm to provide a solid abutment for the surfacing material.
- 221.6 Materials forming the surface and foundations of roads, tracks and footways (Clause 215) may if they are approved by the Contract Administrator be used by the Contractor in the temporary reinstatement of surfaces. The contractor shall provide additional materials necessary for the reinstatement.
- 221.7 In verges and other grass surfaces and after the refilling has been thoroughly consolidated the topsoil shall be re-laid rolled planted with grass as may be necessary watered and attended until the grass has become well established. Should the grass fail it shall be replanted as required until a satisfactory growth is obtained.
- 221.8 Trenches in fields and gardens shall be reinstated to the condition in which the field or garden was before excavation was commenced. The final surface of the trench shall be flush with the surrounding ground.

- 221.9 The Contractor shall take all necessary precautions to ensure that no toxic materials which may cause damage to vegetation or livestock or pollute streams or watercourses are used in any temporary or permanent reinstatement and shall indemnify the Employer against any claims arising out of the use of such materials.
- 221.10 If at any time any trench becomes dangerous the Contract Administrator shall be at liberty to call on the Contractor to restore it to the proper condition at 3 hour's notice.
- 221.11 If the work of reinstatement as carried out by the Contractor is not to the satisfaction of the Contract Administrator and/or the responsible authority and should the Contractor not remedy the defect forthwith any remedial work considered necessary may be undertaken by the Employer and/or the responsible authority at the Contractor's expense.

222 FORMING BANKS AND FILLED AREAS

- 222.1 The Contract Administrator shall mark Banks and filled areas.
- 222.2 Before any filling is started the ground on which embankments are to be sited shall be stripped of all grass and topsoil and all roots vegetable matter and other unsuitable substance removed.
- 222.3 The filling to be used in the embankments and filled areas shall be selected material approved by the Contract Administrator's Representative from that arising surplus from excavation, the material being placed according to its nature as shall be directed, that is, coarse hard material may be placed at the bottom with the fine material and/or soil placed at the top or at the surface.
- 222.4 The filling shall be placed in layers not exceeding 150mm thick each layer being thoroughly compacted by an approved vibratory roller to the satisfaction of the Contract Administrator. Each layer of fill shall be compacted to an average of 95% of Proctor Maximum Dry Density.
- 222.5 Where water has to be added to achieve the optimum moisture content it shall be applied in an even manner. The rate of application shall be such that no transverse or longitudinal flow occurs. The previously compacted surface shall be prevented from drying out by watering prior to placing of next layer.
- 222.6 Where directed by the Contract Administrator that rock shall be used as filling to Embankments, the rock shall be placed in the bottom of the embankment or as directed by the Contract Administrator's Representative. The largest portions of the rock shall be placed in layers the maximum depth of which shall be 0.5m, the interstices filled with the finer material and the whole layer compacted by an approved method.

More fine material shall be added and the layer again compacted until the voids are completely filled.

222.7 All earth moving, placing of fill material, watering, borrowing, and compacting shall be carried out as separate operations to give a clear and controlled method of working.

223 SOILING

222.8 Where required surfaces shall be soiled with fine sifted soil or silt not less than 100 mm compacted thickness which shall be raked and brought to a fine filth. The Contractor shall supply approved material for this purpose.

224 PLANTING

224.1 Surface required to be grassed except verges and other grass surfaces for which the Contractor is responsible in accordance with Clause 221 shall be planted with approved local grass at a spacing of 200m x 200 mm. The grassed areas shall be replanted if the first or subsequent operation is unfruitful or if for any reason the grass is destroyed. Grassed areas shall be watered and attended until the grass has become well established.

224.2 The soiling and planting of the grass in sloped shall be carried out immediately the slope is formed and the grass shall be kept weeded and cut until the work is accepted at the time of the Certificate of Completion

225 DISPOSAL OF SURPLUS EXCAVATED MATERIAL

225.1 All surplus excavated material shall be disposed off to tips to the approval of the Contract Administrator.

225.2 The cost of disposing of surplus excavated material including any specified soiling and grassing shall be allowed for in the rates for excavation.

226 FREE DRAINAGE FILL

226.1 Free draining fill for use as backing to walls shall consist of sound hard stone or broken rock or concrete derived from demolition of structures. The particles shall be roughly cubic form and shall be between 75 mm and 25 mm in size. All smaller particles dust rubbish and organic matter shall be excluded.

227 GRADED GRAVEL FOR DRAINS

227.1 Graded gravel surround to drains shall be clean washed stone or crushed hard rock graded between 20 mm and 5 mm or as specified in the BoQs.

228 ROCK PITCHING

228.1 Rock pitching shall consist of a free draining mixture of broken hard stone obtained from quarries approved by the Contract Administrator which shall have a maximum size of 3000 mm and which shall not contain more than 5% by weight of material which will pass a 10mm B.S. sieve. Between these limits the material shall be reasonably well graded so as to form a free draining blanket without large voids.

229 FORMATION OF FOOTPATHS

- 229.1 The ground footpaths shall be trimmed to formation level and 50 mm thick precast concrete slabs shall be bedded on 50mm thick layer of fine sand.

230 REINSTATEMENT OF TRENCH SURFACES IN ROADS

- 230.1 Materials for both temporary and permanent reinstatement of trenches in road verges, tracks and unmade roads shall be excavated material selected to form a surface similar to the adjoining surface. The surface shall be well compacted.
- 230.2 Temporary reinstatement of trenches in surfaced roads shall comprise a layer of compacted hardcore, of minimum thickness 150 mm, topped with a 75 mm layer of surface material taken from the original surface material taken from the original surface together with any additional material to form a satisfactory running surface. The surface shall be well rolled and sealed with a coat of approved cold applied bituminous emulsion, applied with an approved sprayer at the rate of about 2 litres/m². The emulsion shall be blinded immediately with quarry dust or sand approved by the Contract Administrator's Representative and then rolled with an 8 ton roller.
- 230.3 The quality and grade of bitumen shall be suitable for the climatic conditions of the area and shall otherwise conform to BS 434.
- 230.4 Permanent reinstatement of surfaced roads shall be carried out to the approval of the competent Authority but shall in no way be inferior to that specified elsewhere in the Specification for base of wearing courses to road works. In all cases, the top layer of the temporary reinstatement shall be removed to expose the compacted hardcore which shall be topped up and re-rolled as necessary.

SECTION 3

CONCRETE

INDEX

301	GENERAL	36
302	CONCRETE.....	37
302.1	Requirements.....	38
302.2	Strength.....	39
302.3	Mixes.....	41
302.4	Quality Control.....	42
302.5	Production.....	43
302.6	Cement.....	44
302.7	Aggregates.....	45
302.8	Water.....	47
302.9	Admixtures.....	47
303	REINFORCEMENT.....	47
303.1	Steel.....	47
303.2	Storage.....	48
303.3	Bending and Fixing.....	48
303.4	Couplers for Reinforcement.....	49
304	SHUTTERING.....	50
304.1	Requirements.....	50
304.2	Sawn.....	51
304.3	Wrought.....	52
304.4	Special Wrought.....	52
304.5	Tolerances.....	52
304.6	Striking and Removal.....	53
305	CONCRETING.....	54
305.1	Requirements.....	54
305.2	Transporting.....	54
305.3	Placing and Compaction.....	55

305.4	Cold Weather	58
305.5	Hot Weather... ..	59
305.6	Wet Weather.....	60
305.7	Holes, Cavities and Fixings.....	60
305.8	Protection and Curing... ..	61
305.9	Joints.....	64
305.10	Finishes... ..	68
305.11	Surface Finishes.....	68
305.12	Making good... ..	69
305.13	Removal and Replacement.....	69
306	TESTING...	69
306.1	Sampling and Testing... ..	69
306.2	Loading Tests.....	70
307	SPECIAL CONCRETE.....	71
307.1	No-Fines.....	71
307.2	Air-Entrained.....	71
307.3	Benching... ..	72
307.4	Ready Mix.....	72
307.5	Granolithic	72
307.6	Pneumatically Applied Mortar (Gunitite)... ..	72
307.7	Pumped Concrete.....	74
308	PRECAST CONCRETE	74
308.1	Requirements.....	74
308.2	Weir Blocks and Sills... ..	75
308.3	Coping Blocks and Weir Blade Holders... ..	75
308.4	Kerbs.....	75
308.5	Pavin Slabs... ..	76
308.6	Other Blocks.....	76
308.7	Wall Units	76
308.8	Other Items.....	76
309	SITE BOOKS AND STANDARDS	76
309.1	Instructions to be recorded... ..	76
309.2	Site Diary... ..	76
309.3	Copies of Standards and Codes... ..	77
310	WATER RETAINING STRUCTURES-SPECIAL CLAUSES.....	77
310.1	Making good... ..	77

310.2	Construction Joints in Water Retaining Structures.....	77
310.3	Water tightness of Structures.....	77
3A.1	TESTING OF WATER-RETAINING STRUCTURES.....	78
3A2	CLEANSING AND STERILIZING WATER-RETAINING STRUCTURES.....	78
<u>TABLES</u>.....		79

3.8	Sampling, Testing and Acceptance Standards... ..	80
-----	--	----

301 GENERAL

301.1 The standard of materials and of workmanship shall not be inferior to the recommendations of the current:

- (a) British Standard Code of Practice CP114-)
The Structural Use of Reinforced) whichever is
Concrete in Buildings and CP110 – The) applicable
Structural Use of Concrete.) to the
Or) particular
- (b) British Standard Code of Practice BS 5337) structures
The Structural Use of Concrete for)
Retaining Aqueous Liquids)
and
- (c) Appropriate British Standards
or
- (d) Approved Kenya Bureau of Standards or
Ministry of Works Standards, if any.
Or
- (e) Other equivalent and approved international
standards.

The requirements outlined in the above documents must be read with those of this Section of the Specification and where any conflict exists between the recommendations of the above and of this Specification, the requirements of this Specification shall prevail.

301.2 As and when required by the Contract Administrator the Contractor shall prepare and submit, before commencing the work, a time-chart (additional to the general programme) detailing the various operations for concrete work.

301.3 No material shall be used in the Works until prior approval for its use has been given by the Contract Administrator; neither shall any change in the nature, quality, kind, type, source of supply or manufacture be made without the Contract Administrator's permission.

- 301.4 Names of manufacturers and test certificates for materials not supplied by the Employer shall be supplied as soon as possible to the Contract Administrator.
- 301.5 The cost of providing samples and the cost of carrying out tests required by 306.1 (except as otherwise provided in the Conditions of Contract) together with the cost of supplying equipment for sampling and site testing indicated in columns 3 and 4 of Table 3.7 of this section of the Specification shall be borne by the Contractor (see also Clause 306.1)
- 301.6 During the progress of the Works, consignment notes for materials not supplied by the Employer shall be supplied to the Contract Administrator giving details of each consignment.
- 301.7 The use of the word “approved” in this Specification refers to the approval of the Contract Administrator.
- 301.8 Cross references between certain Clauses of this Specification have been shown in brackets following particular item.

302 CONCRETE

302.1 Requirements

- 302.1.1 The mix proportions shall be selected to ensure that the workability of the fresh concrete is suitable for the conditions of handling and placing, having regard to the structural element being constructed, the disposition of reinforcement, the climatic conditions prevailing and the limitations set by Table 3.1 of this Clause for the particular class of concrete specified.
- 302.1.2 Notwithstanding the strength requirements of this Specification, in order to ensure adequate durability of the finished concrete, while at the same time limiting its shrinkage characteristics, the limits shown in Table 3.1 shall not be exceeded.
- 302.1.3 In all cases of mix proportioning, the added water shall be included with due allowance for the moisture contained in the aggregates and shall be the minimum consistent with the workability requirements. Where difficulty is experienced in maintaining the correct workability for the water-cement ratio outlined in Table 3.1 the use of a water reducing additive may be permitted subject to Clause 302.9
- 302.1.4 Where aggregates do not conform to the moisture requirements of Clause 21.2 of BS 5337 but are permitted for use, in the case of liquid retaining structures the water content indicated in Table 3.1 shall be reduced by 2.5 litres per 50 kg of cement.

Type of Structures	Exposure (Cl.49 BS 5337)		Minimum Cement Content Kg/m ³ finished Concrete					
			OPC			Sulphate Resisting cement		
			Aggregate		W/C	Aggregate		W/C
			40 mm	20 mm		40 mm	20 mm	
Liquid Retaining Surface Structures	A		320	360	0.50	As for Ordinary Portland Cement (OPC)		
Liquid Retaining Substructures Building Foundations	B		260	290	0.55			
Protected Building Structures*	C		220	250	0.60			
Type of Structure	Exposure to Sulphate Condition		Minimum Cement Content Kg/m ³ finished concrete					
			O P C			Sulphate Resisting Cement		
			Total 50% 3	Parts per 100 000 in ground water	Aggregate		W/C	Aggregate
40 mm	20 mm	40 mm			20 mm			
Substructures And Foundations	<0.2	<30	240	280	0.55	-	-	-
	0.2-0.5	30-120	290	330	0.5	240	280	0.55
	0.5-2.0	250-500	-	-	-	290	330	0.5
	1.0-2.0	250-500	-	-	-	330	370	0.45
	>2.0	>500	-	-	-	Ditto with Protective coating		

*Not exposed to liquid or moist or corrosive conditions

302.2 Strength

302.2.1 The basis for assessing the strength of concrete shall be related to the characteristic strength, defined as the strength of the concrete at 28 days, as determined by the standard method of testing (Clause 306.1) below which not more than 5% of the test results shall fall.

302.2.2 The relationship between the class of the concrete and the characteristic strength shall accord with Table 3.2

TABLE 3.2 : Concrete Strength Requirements

Location	Coarse Aggregate Size (mm)	Class and Characteristic Strength N/mm ² 28 Days	Target Strength 7 days
Blinding Concrete	20 or 40	15	10
Blinding Concrete Sulphate Condition	20	25	
Substructures thickness less than 400m	20	25	
Substructures walls and slabs more than 400m	20 or 40	25	17
Superstructures normal concrete	20	20	14
or	20	25	
68. Fine Concrete	10	25	
Precast Concrete	10 or 20	30	20
Prestressed Concrete:	20	30	
Post-tensioned tendons	20	40	
Structural concrete in water towers – all components	20	30	

302.3 Mixes

302.3.1 If, in the opinion of the Contract Administrator, the Prescribed Mix method of proportioning will not produce concrete to satisfy the requirements of this Specification, the mix shall be designed.

(a) Designed Mixes

Proportions shall be determined in accordance with the “Design of Normal Concrete Mixes” published by the British Department of the Environment and obtainable from:-

The Government Bookshop,
P.O. Box 569,
London,
ENGLAND SE1 9NH

or other approved methods, for the requirements set out in Clause 302.1 and 302.2

For the purpose of determining the design mean strength of the concrete a margin shall be added to the characteristic strength (indicated in Table 3.2) for the particular class of concrete. This design margin shall be assessed on the degree of control reasonably to be expected in the manufacture of the concrete and shall not be less than 7.5 N/mm² nor less than 1.64 times the standard deviation. Until such time as the standard deviation has been assessed the margin shall not be less than 15 N/mm².

Details of the designed mixes shall be forwarded immediately to the Contract Administrator for his approval.

(b) Prescribed Mixes

Proportions for the several classes of concrete shall conform to the requirements of Table 50 of CP 110.

(c) Nominal Mixes

Nominal mix proportioning is applicable only to non-structural concrete Class 10 and Class 15 and in special cases when permitted by the Contract Administrator for the other classes of concrete. Proportions shall conform to the requirements of Table 3.2.1

(d) Chloride Content

The total chloride content of the concrete mix shall comply with the requirements of CP 110 Cl. 6.3.8 (as amended November 1980)

TABLE 3.2.1 : Nominal Mix Proportions

Class of Concrete	Nominal Mix
30 or 30(s)	
25 or 25(s)	1 : 1 : 2
20 or 20(s)	1 : 1.5 : 3
15 or 15(s)	1 : 2 : 4
10 or 10(s)	1 : 3 : 6
	1 : 4 : 8

302.4 QUALITY CONTROL

302.4.1 The principal basis of control shall be by comparison of the results of the compression cube tests at 28 days, except for small quantities of concrete whose strength can be otherwise derived and which is permitted for use by the Contract Administrator. 40 sample cubes shall be made initially in eight samples each day for five days of concreting and thereafter one sample in 25 mixes or not less than one for each day's concreting.

302.4.2 Where materials are of an unfamiliar grading or type, compression tests shall be carried out at 7 days and adjustments made in advance of the main control methods outlined above.

302.4.3 Cube test results will be examined individually in 10 consecutive sets of four and the standard deviation and mean strength of each set calculated. The concrete mix proportions will only be acceptable if all of the following requirements are complied with:-

- (i) not more than two results in 40 are less than the characteristic crushing strength
- (ii) no value of the average of any set of four results is less than the characteristic strength plus one-half of the design margin (Clause 302.3)
- (iii) when 40 results have been obtained and the mean strength and standard deviation are calculated, the mean strength minus 1.64 times the standard deviation shall be greater than the characteristic strength.

-
- 302.4.4 Where the results do not confirm to the requirements the following action shall be taken:-
- (a) Adjustments to the mix shall be made to obtain the strength required.
 - (b) In the case where any result is less than 80% of the characteristic strength - in accordance with Clause 305.1. For those prescribed mixes required to be tested, requirements (i) and (ii) only will be applicable.
- 302.5 **Production**
- 302.5.1 Aggregates and cement shall be proportioned by weigh-batching, and water shall be proportioned by volume. Subject to the prior approval of the Contract Administrator volume-batching of aggregates may be used for small sections of work, but volume batching of cement will in no case be accepted. The Contractor may, however, so proportion the mix that each batch shall use a whole bag or bags of cement, the weight of which is known precisely. Where permission has been given for volume batching of aggregates, all gauge boxes shall be accurate and due allowance shall be made for bulking of the aggregates in assessing the correct volume to be used. (Clause 602 of CP 114).
- 302.5.2 The aggregates and the cement shall be thoroughly mixed in a clean mechanical mixer for a period of time agreed with the Contract Administrator and the water added on the basis of the approved design.
- 302.5.3 The amount of water added shall conform to the requirement of Clause 302.1
- 302.5.4 Batch mixing machines shall comply with the requirements of BS 1305. They shall be provided in such numbers and of such capacity as to ensure a continuous supply of freshly mixed concrete at all times during construction.
- 302.5.5 Continuous mixing machines shall be used only with the written permission of the Contract Administrator.
- 302.6 **Cement**
- 302.6.1 Ordinary and Rapid-hardening Portland cement shall comply with BS 12.
- 302.6.2 Sulphate resisting cement shall comply with BS 4027

-
- 302.6.3 High Alumina, super sulphated, pozzolanic, low heat, blast-furnace or other cements shall only be used as directed by the Contract Administrator. They shall not be considered within the scope of this Specification but shall be subject to the requirements of a supplementary specification when required to be used.
- 302.6.4 No extra payment will be made to the Contractor if on his own initiative he used Rapid-hardening Portland cement.
- 302.6.5 Cement shall be fresh when delivered to Site and the consignments shall be used in the order of their delivery. The Contractor shall mark the date of delivery on each consignment and each consignment shall be stored separately and in such manner as to be easily accessible and identified.
- 302.6.6 No cement in bags or other containers shall be used unless these and the manufacturer's seals are intact at the time of mixing.
- 302.6.7 If the cement is delivered in bags it shall be stored in a waterproof shed or building at a temperature of not less than 8⁰C and the bags shall be placed on dry boards above the floor to prevent deterioration or contamination from any cause.
- 302.6.8 Bulk cement may be used provided it is stored in an approved container.
- 302.6.9 The Contractor shall not use cement which has hardened into lumps, but subject to removal of the lumps by screening, the Contract Administrator may allow such cement to be used in non-structural concrete mixes.
- 302.6.10 Cement of different types shall be kept separate in storage and shall not be mixed together in the production of concrete.
- 302.7 **Aggregates**
- 302.7.1 Fine and coarse aggregates shall be as defined by and be of the quality and nature required by BS 882 and BS 1201 whichever is applicable. In addition they shall be chemically inert to alkali reaction.
- 302.7.2 Aggregates shall conform to the requirements of the "Accepted Standards" of Table 3.8.
- 302.7.3 Aggregates of rounded shape or otherwise capable of producing a concrete of good workability with the minimum addition of water shall be preferred.
- 302.7.4 The Contractor shall ensure that the nature and gradings of aggregates remain reasonably consistent, and shall, if necessary,

stockpile and include different gradings to ensure that the overall grading remains constant for each section of the works.

- 302.7.5 Dust or flour resulting from crushing the aggregate shall not be allowed to contaminate the stockpiles. When, in the opinion of the Contract Administrator such contamination has taken place it shall be removed by an approved means or otherwise the aggregate shall be rejected.
- 302.7.6 For mass concrete, in order to improve the consistency of the mix, dust or flour resulting from crushing the aggregate, may, subject to test, be included in controlled quantities to supplement the fine aggregate.
- 302.7.7 The aggregates of various sizes shall be kept separate and away from all possible contamination and shall be stored on a hard-standing area or in bins, provided with proper drainage at the base of the stockpiles.
- 302.7.8 Except where aggregates have been otherwise specified on the Drawings the grading of aggregates shall be as follows:

Coarse Aggregate:

- (a) 10mm max. size, graded, for all “fine” concrete
- (b) 20mm max. size, graded for all reinforced concrete in beams and for walls and slabs not greater than 400mm thick.
- (c) 40mm max. size, graded, for all reinforced concrete walls and slabs in excess of 400mm thick.

Fine Aggregate:

- (a) Where aggregates conforming to zones 2 or 3 of BS 882 are available they shall be used.
- (b) For prescribed mixes, zones 1,2, or 3 aggregates only shall be used.

302.7.9 Sea-dredged Aggregates

Where sound land deposits are readily available locally they shall be used in preference to sea-dredged aggregates. Where however this situation does not exist, the following requirements for the use of sea-dredged aggregates shall apply in addition to those of Clause 302.7 foregoing.

TABLE 3.3 : Shell Content

The shell content shall not exceed the following values:-

Nominal Size of Aggregate mm	% by weight of dry aggregate of shell as calcium carbonate		
	Normal Reinforced Concrete Work	Liquid Retaining Structures	Main Concrete Work
75	Nil	Nil	Nil
40	5	2	5
20	10	5	10
10	15	15	15
Fine Aggregate	40	30	40

Hollow shell shall not exceed one half of the total shell content by weight of 20mm and 40mm sizes.

TABLE 3.4 : Sodium Chloride Content

The sodium chloride content shall not exceed the following values:-

	% Sodium Chloride content by weight			
	Of Dry Aggregate		Of Cement	
	Normal Reinforced Concrete Work	Liquid Retaining Structure	Normal Reinforced Concrete Work	Liquid Retaining Structure
Coarse Aggregate	0.05	0.03	0.50	0.32
Fine Aggregate	0.15	0.10		

Calcium chloride or calcium chloride-containing cements shall not be used with sea-dredged aggregates (C1.302.9)

Cements other than ordinary or rapid-hardening Portland complying with BS 12 and sulphate-resisting complying with BS 4027 shall not be used with sea dredged aggregates.

Where the use of sea dredged aggregates is shown materially to affect the rate of setting of the concrete, the Contract Administrator may require the Contractor to include an approved admixture in the mix at no extra cost (C1.302/9)/

302.8 Water

302.8.1 The Contractor shall supply all water, make all arrangements, and pay all charges in respect of such supply. Where water can be obtained from a public water supply it shall be used.

302.8.2 Where water cannot be obtained from the public supply it shall be tested in accordance with BS 3148 and if necessary shall be treated to assure compliance therewith.

302.8.3 Water for washing and curing shall be such that it will impair neither the strength of the finished concrete nor its appearance.

302.9 Concrete Admixtures

302.9.1 Before approval for the use of a proprietary admixture is given the Contractor will be required to satisfy the Contract Administrator as to its suitability for the work and its compatibility with the cement it is intended to complement.

302.9.2 Preference will be given to the use of admixtures which can be administered in fixed calibrated amounts through a mechanical dispenser or cachet, and which are added directly to the mixing water.

302.9.3 Where approval is given for the use of more than one type of admixture for the same concrete mix they shall be dispensed separately.

302.9.4 In all cases the Contractor shall ensure that careful control is exercised in maintaining correct proportions as laid down by the formulators. Where incorrect proportioning has been carried out, or where the admixture can be shown to have adversely affected the finished concrete, the work shall be treated in accordance with C1.305.13.

- (a) Water-reducing admixtures - The Contractor shall include an approved water-reducing admixture (plasticiser) where, in the opinion of the Contract Administrator, the workability of the mix is otherwise inadequate to achieve an acceptable compaction and/or surface finish, or where excessive bleeding of the concrete is in evidence.
- (b) Air-entraining admixtures - Refer to Clause 307.2
- (c) Set-retarding admixtures - Where large quantities of concrete are to be placed at any one time or where concreting is undertaken under hot conditions, the Contractor may include an approved set-

retarding admixture to reduce the heat of hydration and to enable work to be properly finished before premature setting has taken place.

Where sea-dredged aggregates are used the Contract Administrator may require an approved set-retarding admixture to be included in the mix (C1.302.7.9)

- (d) Set-accelerating admixtures - The Contractor shall not use set-accelerating admixtures in in-situ concrete construction except for cold weather concreting (C1.305.4) or where expressly permitted by the Contract Administrator for a specified purpose.
- (e) Calcium chloride admixtures or ingredients included in propriety type cements shall not be used in reinforced concrete or pre-stressed concrete work.

303 REINFORCEMENT

303.1 Steel

303.1.1 Reinforcement shall be:

- (a) Plain round mild steel or High Yield steel bars conforming to BS 4449.
- (b) Cold worked steel bars conforming to BS 4461 or
- (c) Fabric reinforcement made of cold drawn high tensile bars conforming to BS 4483.

303.1.2 The Contractor shall obtain from his supplies certificates of the mechanical and physical properties of the reinforcement and shall submit them to the Contract Administrator for approval, except where reinforcement has been supplied by the Employer. The frequency of sampling and the method of quality control shall be in accordance with Table 4 and Clause 20 respectively of these British Standards. All high yield and cold worked bars (except in welded fabric reinforcement) shall be deformed bars complying with classification Type 2 for bond strength in accordance with Classification Type 2 for bond strength in accordance with BS 4449 and BS 4461. Where galvanised reinforcement is specified, galvanizing shall comply with the requirements of BS 729, Part 1.

303.2 Storage

Reinforcement shall be stored on Site under cover and supported clear of the ground and in such manner as to make identification easy. Supports shall be such that distorting of the steel is avoided and contamination and corrosion prevented.

303.3 Bending and Fixing of Reinforcement

303.3.1 The Contractor shall provide on site facilities for cutting and bending reinforcement whether he is ordering his reinforcement bent or not and shall ensure that a token amount of straight bar is available on Site for bending as and when directed by the Contract Administrator.

303.3.2 Reinforcement shall be wire brushed and cleaned at the Contractor's expense, before and/or after it is placed in position, if required by the Contract Administrator.

303.3.3 The bars shall be cold bent in strict accordance with the drawings and the Contractor shall be responsible for the accuracy of the bending. Bending dimensions shall be worked to the tolerances indicated in BS 4466 and CP 110 Table 20. Bars in which any errors in bending are beyond the limits of the foregoing tolerances shall be replaced at the Contractor's cost by correctly bent new bars, or, may be straightened and rebent cold subject to the Contract Administrator's prior approval. Any discrepancy or inaccuracy found in the drawings shall be notified to the Contract Administrator immediately.

303.3.3 After assembling, reinforcement shall be securely bundled and labelled with weather-proof tags or shall be marked with other approved signs by which it can readily be identified.

303.3.4 After bending, reinforcement shall be securely bundled and labelled with weather-proof tags or shall be marked with other approved signs by which it can readily be identified.

303.3.5 Before assembling or fixing the reinforcement the dimensions to which it has been bent shall be checked by the Contractor against the drawings

303.3.6 The reinforcement shall be fixed in strict accordance with the Drawings as regards cover, spacing and position, and suitable precautions shall be taken by the Contractor to prevent the displacement of reinforcement during the placing and compaction of concrete.

303.3.7 Where required to support and retain the reinforcement in its correct position the Contractor shall provide templates stools or other supports at his own cost. He shall allow for cutting to correct length all corner lacer bars included in the bar schedules as standard lengths.

303.3.8 Precast concrete support blocks for reinforcement shall be manufactured from Class 30 "fine" concrete to ensure the correct cover thickness. They

shall be well cured before use and carefully stored on Site to avoid contamination. Plastic and metal supports, chairs, etc. may be used subject to the Contract Administrator's prior approval.

- 303.3.9 In the case of mild steel, a lap of not less than 40 diameters of the smaller bar shall be provided at the junction of two bars for which the lap is not specifically detailed on the drawings and, in the case of High Yield steel, a lap of not less than 50 diameters.
- 303.3.10 All intersections of bars in walls and slabs and all connections between binders or links and main bars in columns or beams shall be tied with soft iron wire ties or with fixing clips which shall not be allowed to make contact with the shuttering or to project materially into the specified cover.
- 303.3.11 Unless permitted by the Contract Administrator, welding of bar reinforcement at intersections or for the joining of bars is prohibited. Where permission is granted, welding shall be carried out in accordance with the recommendations of the Institute of Welding for the welding of reinforcing bars for reinforced concrete construction.
- 303.3.12 When fixed reinforcement is to be left exposed for a delayed period of time, it shall be thoroughly cleaned and painted with neat cement grout.
- 303.3.13 Where galvanised reinforcement is used any damage suffered by galvanising shall be made good by the application of an approved galvanising formulation, before concrete placing is commenced.

303.4 **Couplers for Reinforcement**

Couplers for reinforcement shall be either Standard Swaged Splices or Type II Alpha Couplers manufactured by CCL Systems Limited, Cabco House, Ewell Road, Surbiton, Surrey, KT9 7AH, UK., or similar approved. Where bars of different diameters are to be joined a CCL Reducer Sleeve or similar shall be used.

Couplers shall be suitable for the type and size of reinforcing bars and shall be capable of developing 15% of the characteristic strength of the smaller of the compression. Couplers shall be installed in accordance with the manufacturer's recommendations. Square twisted reinforcing bars shall not be used with couplers.

304 **SHUTTERING**

304.1 **Requirements**

- 304.1.1 The term "shuttering" shall be taken to include centering, formwork, strutting, bracing and the like.

-
- 304.1.2 When called upon to do so by the Contract Administrator's Representative the Contractor shall submit his shuttering proposals for checking and approval by the Contract Administrator in advance of the concreting.
- 304.1.3 Shuttering shall be of such accuracy, strength and rigidity as to carry the weight and pressure from the concrete to be placed on or against it, together with all constructional, wind or other loads likely to be imparted to it, without producing deformation of the finished concrete in excess of the tolerances outlined in Clause 304.5 and Table 3.5.
- 304.1.4 All shuttering shall be sufficiently tight, without plugging, to prevent loss of grout during the vibration of the concrete. When required by the Contract Administrator joints between shutter facing boards shall be sealed with foam rubber, sealing strips or other approved material.
- 304.1.5 Faces of shuttering shall be clean, Faces of shuttering shall be clean, free from projecting nails, adhering grout and other imperfections or defects which would prevent the specified surface finish from being attained. They shall be treated with approved mould oil before positioning. Great care shall be exercised to prevent reinforcement or steelwork from being contaminated by the oil during erection of the shuttering.
- 304.1.6 Shuttering, which as a result of prolonged use of general deterioration does not, in the opinion of the Contract Administrator, conform to the particular requirements set out in this clause, shall not be used.
- 304.1.7 Through-bolts or ties will not be permitted in liquid-retaining structures. The Contractor shall use only such bolts or ties as are capable of being removed in whole or in part so that no part remaining embedded in the concrete shall be nearer the surface of the concrete than the specified thickness of cover to the reinforcement.
- 304.1.8 Beam soffits shall be erected with an upward camber of 5mm for each 3 metres of span.
- 304.1.9 Top shuttering shall be counterweighted or otherwise anchored against flotation.
- 304.1.10 Boxes for forming holes shall be constructed so as to be easily removable without damaging the concrete during removal. They shall be properly vented to permit the escape of entrapped air, and shall be capable of being sealed, subsequently to prevent the loss of grout. The use of polystyrene blocks for the forming of holes, sinking, etc. will not be allowed except by express permission of the Contract Administrator.
- 304.1.11 Openings for inspection of the inside of beam, wall, column, and similar shuttering and for cleaning-out purposes shall be formed so that they can conveniently be closed before the placing of concrete.
- 304.1.12 All props shall be supported on adequate sole plates and shall not bear directly on or against concrete. They shall be capable of being released gently and without shock from the supported shuttering. No appliance for

supporting the shuttering shall be built into the permanent structure without the Contract Administrator's prior approval. Props for upper level support shall be placed directly over those at lower levels, and the lowermost props shall bear upon work sufficiently mature to carry the load.

304.1.13 Shuttering shall be such as to allow for its removal without damaging the concrete, and in the case of suspended floors, for the removal of the beam sides and slab soffits without disturbing the beam sides and slab soffits without disturbing the beam bottom boards and their props.

304.1.14 Before concreting, the areas which are intended to receive the concrete shall be cleaned by jetting with compressed air, and all water and extraneous material removed.

304.1.15 Where timber is used for shuttering it shall be properly cured, free from warp, straight, clean, and free from loose knots.

304.1.16 Where metal forms are used for shuttering they shall be of the type strengthened by intermediate ribs or cross bracing.

304.1.17 Moving shuttering may be used where in the opinion of the Contract Administrator it is appropriate.

304.2 **Sawn Shuttering**

Rough finish shuttering shall produce an ordinary standard of finish consistent with normal good practice for use where the face of the finished concrete will not be exposed. The face in contact with the concrete shall consist of sawn timber boards, sheet metal or other approved material.

304.3 **Wrought Shuttering**

Wrought shuttering for use on internal exposed faces and water retaining faces shall produce a high standard of finish consistent with the best practice. The face in contact with the concrete shall consist of wrought and thickened boards tongued and grooved of not less than 30mm finished thickness, framed plywood or metal panels or other approved material. Joints between boards and/or panels shall be arranged in a uniform pattern

304.4 **Special Wrought Shuttering**

Special wrought shuttering shall provide the highest standard of finish where the face of the finished concrete is to form a particular feature. The face in contact with the concrete shall consist of large smooth sheets, unless otherwise specified, arranged in an approved uniform pattern, with joints coinciding with possible architectural features, sills, window heads, or changes in direction or surface. Accurate alignment of all joints shall be maintained. Wrought boarding and standard steel panels shall not be used unless specially faced.

304.5 Tolerances

Unless otherwise indicated on the Drawings, the tolerances of the finished concrete with respect to the dimensions shown on the drawings shall not exceed the limits set out in Table 3.5.

Table 3.5 : Tolerances of Dimensions for Finished Concrete

Items	Tolerance (mm)
Overall dimensions and levels	± 5
Column Sizes)	
Beam Sizes)	
Wall Sizes)	± 5
Vertical lines out of plumb	5mm + 5mm in every 15m ht.

Except that in the case of Rough Finish Shuttering the dimensions of the finished concrete shall be not less than those shown on the Drawings.

304.6 Striking and Removal of Shuttering

304.6.1 The recommendations set out in Table 3.6 are given as a minimum requirement for striking shuttering:-

TABLE 3.6 : Striking of Shuttering

Item	Ordinary Portland Cement	Rapid- Hardening Cement
	Normal Weather 16°C Days	Normal Weather 16°C Days
Beam Sides, Walls, Columns	1	1
Slabs (props left under)	4	3
Beam soffits (Props left under)	7	5
Removal of props to slabs	8	5
Removal of props to beams	16	8

-
- 304.6.2 The above striking times are for normal conditions and before deciding on the actual time for each case, the Contractor shall consider and extend the period as tabled if:-
- (a) the span of the structural member under consideration exceeds 6 metres for beams and 3 metres for slabs. An additional period of one day for each 500mm of additional span shall then be allowed;
 - (b) the dead load of the structural member under consideration forms a large proportion of the total design load;
 - (c) constructional loads coming on to the structural member under consideration are being placed soon after the concreting operations and these loads form a large proportion of the total design load;
 - (d) the setting of the concrete has been retarded for any reasons;
 - (e) the temperature falls below 8⁰C. An additional period of half day shall be added for each day on which the temperature falls below 8⁰C. For temperatures falling below 3⁰C the additional period to be added shall be one day for each day on which the temperature falls below 3⁰C;
 - (f) any combination of the above points and other considerations which would call for such a precaution to be taken.
- 304.6.3 Information regarding paragraph (b) above will be supplied by the Contract Administrator; any other design information relevant to be above shall be obtained by the Contractor from the Contract Administrator.

305 CONCRETING

305.1 **Requirements**

The finished concrete shall be dense, durable, impervious to the ingress of water, free from cracks and honeycombing, and resistant to wear and mild chemical attack. Special concretes will be the subject of their own particular sections of Clause 307.

305.2 **Transporting of Concrete**

305.2.1 Concrete shall be transported to the place of final deposit by approved means.

-
- 305.2.2 Barrows, spades and other equipment used in the process of transporting concrete shall be thoroughly cleaned before each day's work or after a long interruption and they shall be free from hardened concrete.
- 305.2.3 Concrete shall be transported as soon as possible after mixing, by methods which will prevent the segregation, loss or contamination of the ingredients.
- 305.2.4 Proper bridging arrangements for traffic over reinforcement shall be provided so that the reinforcement is not distorted, damaged or displaced.
- 305.2.5 Where approval is obtained for concrete to be conveyed by chutes, these shall have a slope (not exceeding 1 vertical to 2 horizontal) such as to ensure a continuous flow of concrete. Additional water shall not be introduced to assist the flow. If deposition is to be intermittent the chute shall be arranged to discharge into a storage hopper. In no case will a clear fall of more than 1m be permitted at the discharge end of the chute.
- 305.2.6 Where approval is obtained for pumping the concrete, the pump manufacturer's recommendations shall be followed. The pumps used shall be adequate capacity and power to ensure delivery of a continuous supply. The Contractor shall provide adequate alternative arrangements for transporting the concrete in case of a breakdown of the pumping equipment. (see also Clause 307.7).
- 305.2.7 Wherever transport of concrete is interrupted for any length of time (periods over half an hour shall be treated as such) the chutes, pumps, pipes and any
- Other means of distribution shall be thoroughly flushed out and cleaned. These shall also be flushed out immediately prior to resumption of concreting and shall be kept free from hardened concrete. All wash water used shall be discharged outside the shuttering and clear of any freshly placed concrete.

305.3 **Placing and Compaction of Concrete**

- 305.3.1 No concrete shall be placed until the Contractor has obtained approval to do so from the Contract Administrator's Representative. When the Contractor intends to place concrete he shall inform the Contract Administrator's Representative in sufficient time to enable him to inspect the reinforcement, shuttering, and surface on which the concrete is to be placed and the Contractor shall provide all facilities for such inspection.
- 305.3.2 Concrete shall be placed within 30 minutes of mixing, to uniform level, in layers not exceeding 500mm deep in such manner as to avoid segregation, and each layer shall be compacted by means of approved vibrators to form a dense material free from honeycombing and other blemishes. Compaction by hand may be used only with the prior approval of the Contract Administrator.

-
- 305.3.3** Vibration time, the effective radius, and other vibration characteristics shall be in accordance with the vibrator manufacturer's recommendations.
- 305.3.4 If internal vibrators are used, they shall be withdrawn immediately when a thin film of mortar begins to appear on the surface of the concrete. Withdrawal shall be carried out slowly to avoid cavitation.
- 305.3.5 Where two distinct batches of concrete, placed at different periods of time and forming part of the same concreting operation are required to be formed monolithically with each other, the more mature concrete shall be penetrated by the vibrator to a sufficient depth to effect plastic movement between the two batches. Where the concrete does not respond to the action of the vibrator, it shall be deemed to have set, and no further disturbance will be permitted. Unless otherwise instructed by the Contract Administrator the condition shall be treated as for a "stoppage of work" and the marrying up of the two concretes shall be effected only when both concretes have properly set.
- 305.3.6 If shuttering vibrators are used, the shuttering shall be strong enough to withstand the forces of vibration.
- 305.3.7 Temporary or permanent stoppages of work shall be made only against stop ends (Clause 305.9).
- 305.3.8 Unless otherwise specified, before placing new concrete against concrete which has already hardened, the face of the older concrete shall be prepared by the removal of any laitance and loose aggregate, and shall be cleaned by a jet of compressed air.
- 305.3.9 When displacers are permitted to be used they shall be so placed that no displacer is within 300mm of any finished face or within 500mm of any other displacer. On completion of any lift, displacers shall be so arranged that they project for half their height above the surface.

305.3.10 Concreting in Deep Lifts

305.3.10.1 Limitations

Any height exceeding 2.5m from which concrete is poured into shuttering to form sections of wall will be considered within the terms of this Clause.

Deep lift construction will not be permitted where the reinforcing bars are to be placed closer than 100mm to one another in any direction or, where the clear width at the point of admitting the concrete between one layer of reinforcement and another (or in the case of singly reinforced walls between reinforcement and shutter) is less than 200mm.

The method shall only be used where trial sections revealed that, in the Contract Administrator's opinion it can be satisfactorily employed, in which case the requirements of this Specification shall apply except where they are in conflict with the requirements of this particular clause, when the latter shall prevail

305.3.10.2 Concrete

In order to prevent segregation of aggregates, concrete mixes shall be designed for increased cohesion, or, where suitable, on a gap-graded basis. The use of approved admixtures may be made to achieve this end (302.9).

At the same time, the mix shall be such as to limit the amount of bleeding in the concrete, and where in the opinion of the Contract Administrator the quantity of free water rising to the surface is excessive, the mix shall be corrected before further concreting is undertaken.

In order to offset any increase in the water-cement ratio at the upper levels, the Contract Administrator may require the concrete mix to be modified for the upper depositions.

A slump of 80mm shall not be exceeded.

305.3.10.3 **Reinforcement**

In order that reinforcement is not distorted or displaced during construction as a result of it being used for gaining access in or out of the shuttering, all intersections of vertical and horizontal steel shall be properly fastened.

All obstructions caused by spacer blocks or chairs shall be eliminated so as to permit an unobstructed passage for the concrete to the bottom of the shuttering. The Contractor may use sliding timber spacers instead of fixed concrete or plastic spacer blocks to position the reinforcement.

305.3.10.4 **Shuttering**

In view of the high pressures to be expected from this form of construction extra attention shall be paid to the strength and stability of the shuttering, to the prevention of loss of grout, and to the prevention of displacement of adjacent panels.

The use of through-bolts and other accessories which might interfere with the free passage of concrete between and around the reinforcement shall be reduced to a minimum of the use of properly designed shuttering.

305.3.10.5 **Concreting**

Particular attention shall be paid to the concreting of the initial sections at the bottom of the shuttering to prevent segregation caused by rebound from the hard surface of the kicker, base and/or lower sections. The initial depositions shall therefore be made by using trunking methods, or by placing the concrete through openings formed in the sides of the shuttering. Such openings shall not be higher from the hard surface than 2.5m.

In order to reduce differential settlement, and consequently, cracking between two sections of concrete placed at different intervals of time, concreting between one section and another shall be carried out on a gap-construction basis (Clause 305.9). The gap shall subsequently be concreted in distinct lifts each not exceeding 2.5m in height. For the same reason, for concreting two adjacent sections placed at the same time but of different heights (e.g. where boxing out is included), the difference in height shall not exceed 15% of the height of the deeper section.

Concreting from the upper level of the shuttering shall be carried out in such manner as to ensure that concrete is admitted centrally between the faces of the shuttering.

For this purpose the Contractor shall make use of trunking or shall use funnel-shaped hoppers extending for a distance of not less than 1.5m into the shuttering. A sufficient number of such hoppers shall be provided, and/or they shall be capable of movement along the length of the shuttering, to enable the concrete to be placed in contiguous heaps at the base of the pour. Such heaps shall not exceed 460mm in height.

Where excessive bleeding is in evidence, the excess water shall be removed before placing further concrete (see sub-clause 305.3.10.2 of this clause).

305.3.10.6 **Compaction**

Compactions shall be carried out where possible by manual operation of poker vibrators within the shuttering. Where this is not possible poker vibrators shall be suspended in sufficient numbers to ensure uniform compaction along the length of wall receiving the concrete, without the need for their withdrawal and re-insertion. The means of suspension shall be such that the vibrators may be progressively and systematically lifted as the concreting proceeds to ensure that every section of placed concrete is married into adjacent and underlying sections.

The use of vibrators to reposition deposited concrete is prohibited. Surface vibrators attached to the shuttering may be used only to supplement the main means of compaction.

305.4 **Cold Weather Concreting (Using cement to BS 12)**

305.4.1 No concrete shall be placed while the air temperature is below 5⁰C without the permission of the Contract Administrator.

305.4.2 In the event of the Contract Administrator giving permission for concreting to be carried out when the air temperature is below 5⁰C the following conditions shall apply:-

- (a) Concreting shall be at the sole risk of the Contractor and shall be carried out during the day only;

-
- (b) No structural concrete shall be placed on frozen ground;
 - (c) No structural concrete shall be placed on frozen ground;
 - (d) Concrete shall have a temperature of between 16⁰C and 24⁰ C on leaving the mixer and it shall be placed in position and compacted before its temperature has dropped to 5⁰C. To effect this, pre-heating of the mixer, heating of mixing water to a temperature not exceeding 60⁰C, and heating of aggregates to not exceeding 50⁰C is permitted, but on no account shall cement be heated or admitted to the mixer until the aggregates and the water have been thoroughly mixed;
 - (e) If the Contract Administrator gives approval for the use of calcium chloride to accelerate the hardening, not more than 2% by weight of flake calcium chloride (calcium chloride to cement) shall be added. Where proprietary accelerators are used their proportions shall be adjusted to satisfy this requirement. In all cases the calcium chloride shall be dissolved in the mixing water before adding to the mix. Calcium chloride and proprietary accelerators shall not be used with other than Ordinary or Rapid Hardening Portland Cement, nor where sea-dredged aggregates are permitted to be used (Clause 302.7.9);
 - (f) The placed concrete shall not be allowed to fall below 3⁰C until it has thoroughly hardened. The provision of heaters, adequate covering the insulation shall be made as may be required to ensure this. Care shall be taken to prevent over-heating or carbonation of the concrete;
 - (g) The period over which the precautions set out in (f) above shall apply (referred to as pre-hardening period) shall not be less than 3 days unless otherwise permitted by the Contract Administrator. Concrete temperatures shall be taken three times each day, morning, noon and evening, each at two separate positions expected to give the least favorable results;
 - (h) Concrete once placed shall not be subjected to curing techniques involving the application of water to the surface;

The use of steel shuttering, unless insulated, will not be permitted.

305.5 **Hot Weather Concreting (for temperatures above 20 Degrees Centigrade)**

305.5.1 Concreting shall not be permitted if its temperature at placing is in excess of 30⁰C. In order to maintain the temperature of the concrete below this value the following precautions shall be taken wholly or in part as instructed by the Contract Administrator:-

- (i) All aggregate stockpiles, water lines and tanks as well as the mixer shall be protected from the direct rays of the sun;
- (ii) Coarse aggregate shall be cooled by constant watering where possible;
- (iii) Mixing water shall be cooled by the addition of ice to the storage tanks where necessary;

-
- (iv) Rapid-hardening cement shall not be used;
- (v) Where the above precautions are inadequate concreting shall be carried out during the cooler parts of the day or during the night as may be directed by the Contract Administrator.
- 305.5.2 When the air temperature is above 20⁰C loss of mixing water by evaporation shall be considered in arriving at the amount of water to be added to the mix (Clause 302.1). In order to maintain the water/cement ratio within permissible limits an approved water-reducing agent shall be included in the mix (Clause 302.9).
The maximum water/cement ratios indicated in Clause 302.1 may be increased with the Contract Administrator's permission by 0.05) or 2.5 litres/50 kg of cement) during mixing, but on no account shall water be added to concrete directly or indirectly once it has left the mixer.
- 305.5.3 In order to reduce premature drying of the concrete during transporting and placing, all chutes, shuttering and reinforcement shall be cooled by watering when possible, or shall otherwise be protected from the direct rays of the sun. Any water so used shall be removed by jetting with compressed air before placing the concrete in close contact.
- 305.5.4 As soon as possible after concreting, the shuttering shall be stripped (Clause 304.6) and the surface of the concrete shall be treated in accordance with Clause 305.8.
Where drying winds are encountered, wind shields shall be positioned as directed by the Contract Administrator to protect exposed surfaces of the curing concrete.
- 305.6 **Wet Weather Concreting**
- 305.6.1 Concreting during periods of constant rain shall not be permitted unless aggregate stockpiles, mixers and transporting equipment, and the areas to be concreted are adequately covered.
- 305.6.2 During showery weather, the Contractor shall ensure the work can be concluded at short notice by the provision of stop ends. On no account shall work be terminated before each section, between one stop end and another, is complete. Adequate covering shall be provided to protect newly placed concrete from the rain.
- 305.7 **Holes, Cavities and Fixing**
- 305.7.1 The Contractor shall be responsible for the co-ordination of all requirements of his sub-contractors as regards provision of holes, chases, cavities and fixings and shall, if required by the Contract Administrator, prepare drawings giving details of his and his sub-contractors' requirements and shall send copies of such drawings to the Contract Administrator prior to construction.

-
- 305.7.2 Holes, etc. shall be accurately marked and boxed-out for before concreting operations commence and, without the Contract Administrator's prior approval, no such holes, etc. shall be formed after the concrete has set.
- 305.7.3 Where bars, if placed to specified spacing would foul holes of sizes less than 250mm x 250mm the full length of the bar shall be moved to one side and in the case of holes exceeding 250mm x 250mm the bars shall be cut on site and lapped with additional equivalent bars, or as otherwise indicated on the Drawing.
- 305.7.4 Wherever possible, the Contractor shall build in all pipe work, ironwork, etc. which passes through walls and floors, and the pipe work, ironwork, etc. shall first be thoroughly cleaned and freed from any deleterious matter, and every care shall be taken to ensure that it is thoroughly encased in concrete.
- 305.7.5 Bolts, hooks, and other fixings shall be embedded in concrete, or holes shall be drilled and fitted with threaded expanding anchors to receive the bolts. The Contractor shall ensure that bolts, hooks, etc. are accurately positioned. Holding down bolts for machinery shall be set to template.
- 305.7.6 Where brick or stonework is to form a facing to the concrete or where the end of a brick or stone wall butts against a concrete face, galvanized metal ties of approved manufacture to BS 1243 shall be incorporated.
- 305.7.7 The distance between ties shall be gauged with due regard for the bonding of the walls, and at intervals required by the Contract Administrator.
- 305.8 **Protection and Curing of Concrete**
- 305.8.1 Newly placed concrete shall be protected by approved means from rain, drying winds, sun, and contact with substances which can adversely affect it.
- 305.8.2 No traffic or constructional loads shall be permitted on newly placed concrete until it has hardened sufficiently to take such traffic or load, and only then with the approval of the Contract Administrator (305.13).
- 305.8.3 Exposed faces of concrete shall be kept moist after placing for not less than 3 days if Ordinary Portland and 2 days if Rapid Hardening cement is used. Membrane curing by approved materials may be used when permitted by the Contract Administrator.
- 305.8.4 Any concrete surfaces, risers and treads of stairways which might be damaged during the construction of the Works shall be adequately protected.
The method of curing shall prevent loss of moisture from the concrete. Immediately after compaction and for 7 days thereafter concrete shall be protected against harmful effects of weather, including rain, rapid temperature changes and from drying out.

The curing time shall be the number of days given in the following table unless the average temperature of the concrete during the required number of days falls below 10⁰C in which case the period curing shall be extended until the maturity of the concrete reaches the value given in the table. Curing shall be carried out using either of the following basic methods. The method adopted for any particular situation shall be agreed with the Contract Administrator.

A. Membrane Applied by Spray

Liquid membrane compounds shall be applied to moist concrete surfaces as follows:-

(i) Uniformed Surfaces

The compound shall be applied immediately after the free water has left the surface.

(ii) Formed Surfaces

The compound shall be applied immediately after removing the forms. If there is appreciable drying, the surface shall be mist sprayed with water to produce a uniformly damp appearance before the compound is applied.

The compound shall be applied in one or two separate applications to produce complete and uniform coverage of the surface. If the compound is applied in two increments, the second application shall follow the first within 30 minutes. The method and rate of application shall be in accordance with the compound manufacturer's instructions.

If rain falls on the newly coated surface before the film has dried sufficiently to resist damage, or if the film is damaged in any other manner, a new coat of compound shall be applied to the affected area in curing value to that originally applied.

Compound applied to construction joint surfaces, or to other surfaces to which concrete are to be bonded, shall be remove prior to placing the fresh concrete.

Depending on the surface to which it is to e applied the compound shall conform to the following requirements of AASHTO M148.

- (i) Exposed and vertical concrete surfaces - Type I-D (clear compound with fugitive dye).
- (ii) Unexposed top surfaces of foundations and superstructures – Type 2 (white pigmented).

B Polythene Sheeting

The concrete surfaces shall be covered with white polythene sheeting as follows:-

(i) Unformed Surfaces

The sheeting shall be laid over the surface as soon as possible without marring the surface, and not until initial stiffening has taken place if a brushed or tamped finish is required.

(ii) Formed Surfaces

The surfaces shall be covered immediately after the removal of the forms.

Details of all curing methods used shall be subject to the approval of the Contract Administrator.

The sheeting may be in contact with the concrete or made into portable shelters on light weight frames. In both cases, the sheeting shall be jointed and sealed against the concrete surfaces to prevent wind blowing between the sheeting and the concrete.

The white polythene sheet shall conform with the requirements of AASHTO M171.

C. Other Curing Methods

These shall be agreed with the Contract Administrator. Methods involving the use of damped hessian coverings shall not be used.

Details of all curing methods used shall be subject to the approval of the Contract Administrator.

TABLE 3.7: Normal Curing Periods

Minimum period of protection for different types of cement

Conditions under which concrete is maturing	Number of days (When the average temperature of the concrete exceeds 10 ⁰ C during the whole of the period)			Equivalent maturity (deg.C Hors) (calculated as the age of the concrete in hours multiplied by the number of degrees Centigrade by which the average temperature of the concrete exceeds – 10 ⁰ C)		
	Type IV	Type I or Type V	Type III	Type IV	Type I or Type V	Type III
1. Hot weather or drying winds	7	4	2	3500	2000	1000
2. Conditions not covered by 1.	4	2	1	2000	1000	500
Type IV - Low Heat Portland Cement Type I - Ordinary Portland Cement Type III - Rapid-hardening Portland Cement Type V - Sulphate-resisting Portland Cement						

Where the thickness of concrete placed exceeds 1.5m, the Contractor shall submit for the Contract Administrator's approval proposals to ensure that, during the curing period:-

-
- (a) the rate of rise of temperature in the concrete does not exceed 15⁰C per hour for the first 3 hours;
 - (b) thereafter the rate of rise and fall of temperature in the concrete does not exceed 35⁰C per hour;
 - (c) the maximum difference temperature in the concrete does not exceed 70⁰C; and
 - (d) the maximum difference in temperature between the core and the surface of the concrete does not exceed 20⁰C.

The proposals shall include consideration of:-

- (a) concrete mix design;
- (b) temperature of mix at time of placing;
- (c) Method of curing.

Where required by the Contract Administrator, the Contractor shall carry out temperature measurements in the concrete. The method and procedure of temperature measurement shall be agreed with the Contract Administrator.

305.9 Joints

305.9.1 Construction Joints

The position of construction joints, when not shown on the Drawings or otherwise required by this Specification, shall be decided on site having regard to the plant and labour made available by the Contractor for the manufacture, placing and compaction of the concrete as well as its curing, the climatic conditions prevailing at the time of concreting, the nature and size of the shuttering, and the conditions of operation of the work. The contractor shall submit his proposals to the Contract Administrator for his approval before commencing work.

Construction joint surfaces shall be treated by the “wash-off” method explained below, except in the case of Cold Weather Concreting (Clause

305.4) or where it cannot be practically effected, in which case it shall be treated in accordance with Clause 305.3 as for the placing of new concrete to hardened concrete.

When expanded metal lathing is used for the formation of construction joints a rebate will not be required to be formed. The expanded metal lathing shall be left in the work and shall not extend closer to the finished

surface of the concrete than 25mm. It shall be securely fixed to the reinforcement.

The following particular requirements shall also be observed: -

(i) Slabs supported on the ground

In order to ensure control in the placing of concrete the Contractor shall provide control boards to form panels not larger than 15m² in area. These shall be lifted as the concreting proceeds except where they are of expanded metal in which case they may be left in position as part of the permanent works, provided that they shall not extend closer to the finished surface of the concrete than 25mm. In the event of a breakdown in the supply of concrete the Contractor shall ensure that an alternative supply of concrete is made available (to finish the work against the control boards acting as stop ends). The joint so formed shall then be treated as a construction joint. Where ready-mixed concrete is permitted (Clause 307.4) the control boards shall be positioned so as to enclose a volume of concrete equal to that delivered by each truck.

Construction joints and control joints shall be formed normal to the surface of the retained concrete.

(ii) Suspended Beams and Slabs

The reference to control boards in the foregoing para. (I) shall apply, but generally, unless otherwise shown on the Drawings or permitted by the Contract Administrator, construction joints shall be positioned at approximately midspan in both beams and slabs.

T-beams shall be formed to their full depth integrally with the adjacent slab and without horizontal joints.

(iii) Walls

Horizontal construction joints in walls shall be formed along straight lines coinciding with the full height of the shuttering. The height of the shuttering thus controlling the height of the pour shall be determined with reference to the availability of concrete, the size, and amount of reinforcement and the means of compaction available.

Unless otherwise indicated on the Drawings or otherwise permitted by the Contract Administrator for the construction of circular tanks, concreting shall be carried out continuously for the full circumference without vertical joints. Where permission is granted for the use of vertical joints the Contract Administrator may order, at no extra cost to the Employer, the inclusion of an approved type of water stop.

In the case of rectangular tanks, vertical joints shall not be positioned closer to any corner than one metre. They shall be formed with properly rebated stop ends or, where conditions permit, by the use of expanded metal lathing.

Un-reinforced manholes shall be constructed without vertical joints.

305.9.1.1 The “Wash-off Method” of preparing Construction Joints

As soon as possible after concreting, and while the surface is still green, the surface of the concrete forming the joint shall be freed of loose aggregate and sprayed with a fine spray of water to prevent the formation of laitance. Subsequently all excess water shall be removed by a jet of compressed air and the surface left clean to receive further concrete.

Where expanded metal lathing is used for construction joints, this method of surface preparation shall be used in every case.

305.9.2 Movement Joints

These shall include contraction and expansion joints and shall be as indicated on the Drawings.

Contraction joints will be either full contraction joints or partial contraction joints. Where partial contraction joints are specified a period of at least five days shall elapse between the concreting of the section on each side of the joint.

Where the Drawings indicate a contraction gap to be formed in any panel (this gap will not exceed one metre), concreting on either side of the gap shall be carried out so as to form partial contraction joints at each side of the gap.

Prior to the concreting of the gap section, the joint surfaces shall be cleaned but otherwise left untreated. The concreting of the gap section shall not be carried out until a period of at least five days has elapsed after completion of the adjacent sections.

Alternate panel construction (other than contraction gap construction outlined above) will be permitted only with the approval of the Contract Administrator, or in those cases where either the reinforcement is not continuous through the joint or where the panels are separated by expansion or contraction joints.

Unless otherwise specified or permitted by the Contract Administrator all water stop shall consist of rubber. Jointing of water stop shall be by vulcanizing, except where PVC is specified or permitted in which case joints shall be by fusing or welding. Materials shall be obtained from an approved manufacturer whose recommendations as to jointing shall be fully complied with.

305.9.3 Water stop and Jointing Materials

305.9.3.1 Water stop and jointing materials shall be obtained from an approved manufacturer.

305.9.3.2 All water stop and jointing materials which are not required for immediate use shall be stored at all times in a cool damp place.

305.9.3.3 Water stop shall be manufactured of rubber or PVC (polyvinylchloride) as stated in the Bill of Quantities and shall be made strictly in accordance

with the manufacturer's instructions and all intersections and junctions shall be obtained prefabricated from the approved manufacturer.

305.9.3.4 Joint filler shall be manufactured of natural bonded cork or other approved material. Joint filler shall be cut and trimmed accurately to suit the joint profile and shall be maintained accurately in position by means of an approved adhesive.

305.9.3.5 Joint sealing compounds shall be approved rubber/bituminous compounds suitable for sealing joints in horizontal and vertical/sloping concrete surfaces as appropriate. Sealing compounds shall be applied strictly in accordance with the manufacturer's instructions and shall completely fill the joint recess. Surface primers shall be from same manufacturer as the sealants themselves.

305.9.3.6 Water stop shall be located and maintained accurately in position and details of the proposed method of fixing shall be submitted to the Contract Administrator for approval. On no account shall water stop be secured by nails or by any other means involving puncture of or damage to the water stop material unless purpose made nailing flanges are incorporated in the design of the water stop.

305.10 **Finishes to concrete - General**

305.10.1 All exposed faces of concrete unless otherwise specified shall be hard, smooth and free from honeycombing, air and water holes and other blemishes.

305.10.2 All projecting imperfections shall be rubbed down with carborundum stone or by other approved means and grit and dust there from shall be thoroughly washed off with clean water.

305.11 **Surface Finishes**

(a) Wood float finishes shall be formed by smooth floating the accurately leveled and screeded surface. Care shall be taken to ensure that the concrete is worked no more than is necessary to produce a uniform surface free from screed marks.

(b) Steel trowel finishes shall be formed while the concrete is still wet by means of a steel trowel applied to an accurately leveled and screeded surface (see also Clause 307.3)

(c) Granolithic finishes shall conform to the recommendations laid down in "Specification for Granolithic floor toppings laid in in-situ concrete", as published by the cement and Concrete Association with special reference to monolithic construction.

(d) Screeded finishes shall be formed by leveling and screeding the concrete to produce a uniform, plain or ridged surface as specified.

-
- (e) Bush-hammered or patter-worked finishes.

When exposed aggregate is to be the surface texture, the Contractor shall ensure that a uniform distribution of the coarse aggregate takes place at the face. The shuttering shall be removed as soon as possible from the face to be treated; the surface shall be thoroughly wetted and wire brushed, and bush-hammered or pattern-worked as and when instructed. Surface retarders shall be used only when permitted by the Contract Administrator.

Bush-hammering or patter-working shall not be relied upon to obscure any defects in the concreting face which arise from shuttering imperfections.

305.12 **Making Good**

Honeycombed or damaged surfaces of concrete, which in the opinion of the Contract Administrator, are not such as to warrant the cutting out and replacement of the concrete, shall be made good as soon as possible after removal of the shuttering as follows:-

1:1.5 Portland Cement and sand mixture shall be worked into the pores over the whole surface with a fine carborundum float in such a manner that no more material is left on the concrete face than is necessary completely to fill the pores so that a uniformly smooth and dense surface of uniform colour is finally presented.

305.13 **Removal and Replacement of Unsatisfactory Concrete**

The Contractor shall on the Contract Administrator's instructions to do so cut out and replace any concrete in any part of the structure if in the Contract Administrator's opinion:-

- (a) the concrete does not conform to the Specification, or
- (b) deleterious materials or materials which are likely to produce harmful effects have been included in the concrete, or
- (c) the honeycombed or damaged surfaces are too extensive, or
- (d) the finished concrete sizes are not in accordance with the Drawings within permissible tolerances, or
- (e) the setting-out is incorrect, or
- (f) the steel cover has not been maintained, or
- (g) the protection, including curing, of the concrete during the construction was inadequate, resulting in damage, or

-
- (h) the work of making good or other remedial measures the Contract Administrator may indicate are not carried out to his satisfaction, or
 - (i) Undue deformation of or damage to the works has taken place due to inadequate shuttering, or to premature traffic or to excessive loading, or (j) any combination of the above points has taken place resulting in unsatisfactory work.

306 TESTING

306.1 Sampling and Testing (see also Clauses 301.0 and 302.4)

306.1.1 The contractor shall provide on the Site equipment, staff and labour for carrying out the sampling and testing outlined in columns 3 and 4 of Table 3.8, and he shall carry out any or all of these tests at such times and with such frequency as may be requested by the Contract Administrator.

306.1.2 All equipment shall be calibrated and checked from time to time as the Contract Administrator may require.

306.1.3 The Contractor shall provide samples required by the Contract Administrator. Those samples to be tested in a laboratory as required by Column 5 of Table 3.8 shall be carefully forwarded by the Contractor to an approved laboratory. Results of laboratory and site tests shall be kept on site and copies of all test reports shall be forwarded in duplicate to the Contract Administrator's Representative.

306.1.4 Frequency of tests and the number of samples required will be governed by the results of the previous tests, the quality of the materials revealed during the tests, and the uniformity of the quality (see Clause 302.4). Should it become evident that the quality of concrete is deteriorating the Contract Administrator may require additional samples to be taken and test cubes to be made and tested to determine the cause.

306.2 Loading Tests

306.2.1 The Contract Administrator may direct that a loading test be made on the works or any part thereof if he deems such test to be necessary for one or more of the following reasons:-

- (a) failure of "Site Cubes" to attain the strength requirements of Clause 302.4;
- (b) premature removal of shuttering;
- (c) overloading of structure during construction;
- (d) improper compaction and/or curing of concrete;

-
- (e) any other circumstances attributable to alleged negligence on the part of the Contractor, which in the opinion of the Contract Administrator, may result in a structure being of less than the required strength;
- 306.2.2 If the loading test be ordered to be made solely or in part for reasons (a) to (d) the test shall be made at the Contractor's own cost.
- 306.2.3 If the loading test be ordered to be made for reason (e), the Contractor shall be reimbursed for the cost of the test if the result is satisfactory.
- 306.2.4 Loading test shall be carried out in accordance with Clause 9.5 or 9.6 of CP 110 as appropriate.
- 306.2.5 If the results of the test are not satisfactory, the Contract Administrator will direct that the part of the work concerned by taken down or removed and reconstructed to comply with the Specification, or that such other remedial measures as he may think fit be taken to make the work acceptable and the Contractor shall carry out such work at his own cost.
- 306.2.6 The Contract Administrator may also instruct the Contractor before a loading test takes place to take out cylindrical core specimens from the structures concerned and have them tested. The cutting equipment and the method of doing the work shall be to the Contract Administrator's approval. The specimens shall be dealt with in accordance with BS 1881. Prior to testing, the specimens shall be available for examination by the Contract Administrator. If the cores are ordered to be taken solely or in part of reasons (a) and (d) above, the work involved and the testing shall be made at the Contractor's own cost. If the cores are to be taken for reasons (b), (c) and (e) above, the Contractor will be reimbursed the cost if the loading test described in the previous paragraphs proves satisfactory.

307 SPECIAL CONCRETE

307.1 No-fines Concrete

- 307.1.1 No-fines concrete for use in subsoil drainage shall consist of a 1:8 cement/aggregate mix by volume. Aggregate shall be 20mm to 10mm graded with no more than 5% passing the 10mm sieve. Only sufficient water shall be added to ensure complete coating of the aggregate. One half of this water shall be placed into the mixer first, after which the aggregate and cement shall be admitted. After partial mixing the balance of the water shall be added until a consistency of mix is achieved.
- 307.1.2 Preliminary tests shall be carried out on the site to prove the suitability of the finished concrete, and adjustments made to the proportions and or grading as may be required by the Contract Administrator.

307.2 Air-Entrained Concrete

-
- 307.2.1 Concrete for roads, and those structures where specified, shall include an approved air-entraining agent capable of producing a 5% air-entrainment with a tolerance of 0.5% (Clause 302.9)
- 307.2.2 The mix shall be purposely designed, having regard for the nature of grading of the aggregates and air-entraining agent being used.
- 307.2.3 Preference shall be given to the use of air-entraining agents which can be administered in fixed calibrated amounts through a dependable mechanical dispenser or sachet, and which are added to the mixing water.
- 307.2.4 Frequent air meter tests shall be carried out and the consistency of the air-entrainment maintained to the above tolerances by adjustments in the mix, as may be necessary.
- 307.3 Concrete in Benching**
Concreting for benching in manholes, pumping stations, and works structures shall consist of Class 20 concrete unless otherwise specified. It shall be placed with low workability to the approximate shape required and, while still green, shall be finished with not less than 50mm of Class 25 concrete to a steel trowelled finish and to the contours indicated on the drawings.
- 307.4 Ready Mixed Concrete
- 307.4.1 Unless otherwise stated the relevant clauses of BS 1926 shall apply.
- 307.4.2 Ready mixed concrete shall only be used with the prior approval of the Contract Administrator. The Contractor shall not be relieved of his obligation to provide concrete to the standard laid down in this Specification by virtue of any approval given for the use of concrete supplied by others, and the Contract Administrator reserves the right to withdraw his approval at any time consequent on any deterioration in the quality of the Concrete, or unsatisfactory delivery or any other reason he considered detrimental to Works.
- 307.4.3 Ready mixed concrete manufactured off the site shall be transported in a revolving drum and shall be continuously agitated until it is used in the work unless otherwise approved. The time interval between adding water to the drum and placing shall not exceed 90 minutes. The time interval between completion of mixing and placing shall comply with Clause 305.3.
- 307.5 **Granolithic Concrete**

Refer to Clause 305.11

307.6 Pneumatically Applied Mortar (Guniting)

307.6.1 Requirements

The pneumatic application of mortar shall be carried out only by Contractors experienced in this type of work and who are in possession of proper plant and equipment. Nozzlemen employed on the works shall be skilled operators.

The finished product shall be dense, of even texture and colour, and to the requirements of strength, tolerance, and finish set out in this Specification.

307.6.2 Strength

After curing, the mortar shall be capable of producing cored samples with a 28-day characteristic strength of not less than 27.5 N/mm².

307.6.3 Materials

Sand, cement and water shall comply with the requirements of Clause 302.6, 7 and 8 of this Specification except that the sand shall conform to the grading of Zone 2 of BS 882.

307.6.4 Proportions

The proportions to be used in mix shall be determined with reference to the requirements outlined in sub-clause 307.6.1 and the mix shall be not weaker than one part of cement to the four parts of sand by volume, having regard to the adjustments for bulking of the sand.

307.6.5 Operation

Air and water pressures shall be such as to permit of the proper application of the mortar, and shall be determined with reference to hose lengths and nozzle diameter.

Rebound, recovered, cleaned and uncontaminated with extraneous matter, may be re-used but not for water-retaining structures. It shall be regarded as an equivalent volume of sand which shall not exceed 20 per cent of the total sand requirement. Rebound which has lodged in the shuttering or between reinforcement shall be removed by compressed air.

Reinforcement shall be completely embedded in the mortar by the proper direction of the nozzle and the mortar shall be applied as a steady and uninterrupted flow from the nozzle.

Mortar application shall be discontinued at any section of the work where sagging of the mortar is in evidence.

307.6.6 Joints

These shall be formed by sloping the surface to a thin edge. Before applying new mortar, the surface shall be thoroughly wetted. Laitance shall be removed by the initial discharge of fresh mortar.

307.6.7 Tolerance

The thickness of applied mortar shall be not less than the dimensions shown on the Drawings nor greater than 10mm over those dimensions, unless otherwise indicated on the Drawings or otherwise permitted.

307.6.8 Protection and Curing

Shall be carried out in accordance with the requirements of Clause 305.8

307.6.9 Finishes

Unless otherwise specified all surfaces shall be brought to a granular textured finish by means of wooden float.

307.6.10 Cold Weather Work

No application of mortar shall be made against frozen surfaces nor when the air temperature is below 5⁰ C.

307.6.11 Making Good

Any defective work shall be cut out immediately and made good with fresh mortar pneumatically applied.

307.7 **Pumped Concrete**

Where pumping of concrete is permitted to be used not relaxation of this Specification will be permitted. Particular attention shall be paid to the proper grading of aggregates to prevent bleeding and/or segregation during the pumping operations. The inclusion of water-reducing additives or other materials, including flyash, to improve the flow characteristics of the concrete will only be permitted where it can be shown that they do not adversely affect the concrete either in the plastic phase or in the finished work (Clause 302.5).

308 PRECAST CONCRETE UNITS

308.1 Requirements

308.1.1 Precast concrete units, unless otherwise stated, shall be obtained from an approved manufacturer and shall be true to dimension and shape, with true arises and with perfectly smooth exposed faces free from surface blemishes, air holes, crazing and other defects, whether developed before or after building-in. They shall comply with the appropriate BS. (Note: Coping blocks and similarly exposed units are particularly susceptible to crazing when the concrete is manufactured using high water/cement ratios.

308.1.2 The requirements of Table 3.1 shall be rigidly adhered to on all occasions therefore, and where units are supplied by others, the Contractor shall

inform the Supplier of these requirements). In addition, the following requirements particular to the various units shall be complied with:- (Clause 308.2 to 308.8 inclusive.)

308.2 Weir Blocks and sills

308.2.1 Aggregates for the making of weir blocks and sills shall conform to BS 1201, except that the use of soft or weathered limestone coarse aggregate will not be permitted. Fine aggregate shall consist of sand resulting from the natural disintegration of rock. Blocks and sills shall be tested for water absorption in accordance with BS 340 and shall display neither greater absorption than 2.5% after 10 minutes nor 6.5% after 24 hours immersion, the percentage being based on the dry weight of the test pieces. In addition, they shall exhibit no visible signs of distress when subjected to an approved freeze-thaw test based on thirty cycles of exposure. After such a test the compressive strength of the test piece shall be not less than 80% of the strength of a similar piece which has not been subjected to the test.

308.2.2 Weir blocks shall be ground to a polished surface on the upper and discharge faces.

308.3 Coping Blocks and Weir Blade Holders

308.3.1 These units shall conform to the requirements for weir blocks stated above but without polishing shall be brought to a smooth surface on the exposed faces.

308.3.2 Coping blocks of thickness 60mm or less shall be formed by pressing, by employing pressures not less than 6.5 N/mm² over the entire surface receiving the pressure, before being brought to the required finish.

308.4 Kerbs

308.4.1 Precast concrete kerb shall conform to BS 340, except that coarse aggregate shall conform to BS 1201. Fine aggregate shall consist of sand resulting from the natural disintegration of rock.

308.4.2 Approved air-entraining agents may be permitted to be used providing that approved adjustments are made to the mix with regard to water and fine aggregate proportions (Clause 302.9). In such cases the moisture absorption limits set out in BS 340 may be neglected subject to the concrete satisfying the freeze thaw test laid down under the heading “Weir Blocks and Sills”.

308.5 Paving Slabs

Paving slabs shall conform to BS 368 and shall be 50mm thick unless otherwise specified.

-
- 308.6 **Other Blocks**
Blocks used for building work and filter bed walls shall conform to BS 1364/BS 2028.
- 308.7 **Walls Units**
L-shaped wall units shall conform to the requirements of CP 116. Where it is not intended to use coping blocks for the protection of the upper exposed surface of the units, the uppermost 150mm, for the full width of the unit, shall be formed with concrete composed of aggregate complying with BS 1201. Such concrete shall be formed integrally with the main body of the concrete.
- 308.8 **Other Items**
Manhole ring units, tapers, cover slabs, segments, and concrete pipes are referred to under their particular heading.
- 309 **SITE BOOKS AND STANDARDS**
- 309.1 **Instructions to be Recorded**
The Contractor shall provide and keep permanently on the Site a numbered triplicate book wherein the Contractor shall record all instructions relating to concrete work issued by the Contract Administrator or the Contract Administrator's Representative. One copy of every entry therein shall be sent to the Contract Administrator on the same day as the entry is made.
- 309.2 **Site Diary**
The Contractor shall provide and keep permanently on the site a continuous entry diary wherein the Contractor shall record details of shuttering, construction, placing of reinforcement, concreting and curing operations, striking of shuttering, making good and daily temperature, and weather conditions. This diary shall always be available for inspection by the Contract Administrator or Contract Administrator's Representative.
- 309.3 **Copies of Standards and Codes**
The Contractor shall provide and keep permanently on the Site copies of the following British Standard Codes of Practice and Road Notes:-
 BS 812
 BS 882
 BS 1478
 BS 1881
 CP 110

The Contractor shall in addition provide and keep permanently on the site copies of such other Standards codes Notes and Specifications as may be approved by the Contract Administrator in accordance with Clause 7 of the Notice of Tenderers.

310 WATER RETAINING STRUCTURES - SPECIAL CLAUSES

Note: In the event of any difference between the “Special Clauses” and the previous Specification under Section 3 then the provision of these “Special Clauses” shall have precedence.

310.1 Making Good

The cement mortar used in filling recesses in the concrete formed by bobbins in connection with shuttering shall contain an approved expanding admixture.

310.2 Construction joints in Water Retaining Structures.

310.2.1 In water retaining structures PVC water stops not less than 130mm wide manufactured by an approved manufacturer shall be built into all construction joints in floors all vertical construction joints in walls which are exposed externally and construction joints in roofs of potable water retaining structures. Construction joints shall be formed at positions agreed by the Contract Administrator.

310.2.2 The cost of forming construction joints shall be included for by the Contractor in his general concrete rates

310.3 Water tightness of Structures

The contractor shall be solely responsible for the water tightness of structures and any remedial measures necessary.

SECTION 3A - TESTING AND STERILIZING CONCRETE WATER-RETAINING STRUCTURES

3A.1 TESTING OF WATER-RETAINING STRUCTURES

3A.1.1 all water-retaining structures shall be tested for water-tightness on completion in the following manner. The structure shall be filled with clean water in stages of one metre and held at each water level for such time as the Contract Administrator may require. Should any dampness or

leakage occur at any stage, the water shall be drawn off the defects remedied to the satisfaction of the Contract Administrator.

The procedure shall be continued and finally the structure shall be allowed to remain full for three days during which the total permissible loss of water, after allowing for evaporation, shall not exceed 1/1000 of the capacity of the structure. Notwithstanding the satisfactory completion of the seven day test, should any dampness or leakage or other defects occur they shall be made good to the satisfaction of the Contract Administrator and the structure re-tested until water-tightness is approved by the Contract Administrator.

- 3A.1.2 The Contractor shall provide a hook gauge to measure variations in the water level during the tests.
- 3A.1.3 The testing shall be carried out before the excavations are backfilled and Embankments placed.
- 3A.1.4 In the case of potable water reservoirs and tanks the roof shall be tested for water-tightness by flooding (in small areas at a time if necessary) to a minimum depth of 25 mm. The water shall be left standing for not less than 24 hours and the underside of the roof shall be made good by the Contractor and the tests continued until the water-tightness of the roof is approved by the Contract Administrator. Where it is not practicable to contain a depth of 25mm of water over the roof, the roof shall be thoroughly wetted by continuous hosing for a period of six hours.
- 3A.1.5 The Contractor shall be solely responsible for the water tightness of structures and any remedial measures necessary.
- 3A.1.6 The water used for testing shall be provided at his own expense by the Contractor and shall be free from impurities and of such quality which will not pollute or impair the water-retaining structure.
- 3A.1.7 The Contractor shall give the Contract Administrator's Representative at least 14 days' notice as to the source of water intended for use for testing purposes.
- 3A.1.8 The Contractor shall be solely responsible for making all arrangements for obtaining water and provision of all equipment and labour and other things necessary for testing water retaining structures.

3A.2 CLEANSING AND STERILIZING WATER-RETAINING STRUCTURES

- 3A.2.1 The inside of all potable water-retaining structures and all interior pipe work and fittings shall be thoroughly cleaned and washed after the water-tightness test has been approved by the Contract Administrator to remove all contamination and the water from these operations shall be removed by squeegees and drained away.
- 3A.2.2 The internal surfaces of the structure shall then be thoroughly washed with cleaned water containing 20 parts per million of chlorine. The chlorinated water shall then be drained away and the structure filled with potable water from which, after 24 hours, samples shall be taken for analysis to the instruction of the Contract Administrator. If any of the results of the

analyses are unsatisfactory when compared with those of the control sample of the supply water the sterilizing process shall be repeated until the results of the test are satisfactory.

- 3A.2.3. The costs of the initial sampling analysis and preparing reports on the bacteriological quality of the water shall be borne by the Employer but should initial reports be unsatisfactory the costs of any subsequent sampling analyses and preparing reports shall be borne by the Contractor.

TIME 3.8 SAMPLING, TESTING AND ACCEPTANCE STANDARDS

Materials	Test	Site Sampling	Testing		Accepted Standards	Remarks
			On Site	In Laboratory		
1	2	3	4	5	6	7
CEMENT	Ordinary Portland Rapid Hardening Sulphate Resisting			BS 4550	BS 12 BS 12 BS 4027	Manufacturers Test Certificate
AGGREGATES	Description and Classification		BS 812 Section 2		BS 882 or 1201	Whichever is applicable
	Particle size	BS B12 Sec.1	BS 812 Sec.5	-	BS 882 or 1201	
	Particle Shape	BS 812 Sec. 1	Visual	BS 812 Sec.3		
	Sp. Gravity	BS 812 Sec.1	-	BS 812 Sec.5		Mix design
	Density	BS 812 Sec.1	-	BS 812 Sec.3		Requirements
	Voids	BS 812 Sec.1	-	BS 812 Sec.4		
	Absorption	BS 812 Sec.1	-	BS 812 Sec.4	US 5337 CI.21.2	See Freeze-
	Organic Impurities		-	BS 812 Sec.5		
	Bulking of Fine Aggregate		CP 114 CI 602			Nominal Mix Proportionary
	Moisture Content			BS 812 Sec.5		For adjustment if added water for concrete making
	Mechanical Properties			BS 812 Sec.6	BS 882 or 1201	Ten per cent fines value

TABLE 3.8 SAMPLING, TESTING AND ACCEPTANCE STANDARD (Cont'd)

Materials	Test	Site Sampling	Testing		Accepted Standards	Remarks
			On site	In Laboratory		
Water	Suitability	BS 3148	-	BS 3148	BS 3148	Not required for potable water
Concrete	Compacting Factor Slump	BS 1881 Pt.1	BS 1881 Pt.2	BS 1881 Pt.2	This spec. Table1 CI.302	Workability Tests
	Crushing			BS 1880 Pt.4	Table 2 this Spec.	Cube Test
	Flexural			BS 1881 Pt.4	CP 114 CI.208c	As required
	Water Absorption	CP 114		BS 1881 Pt.5	BS 340 Para 19(b)	Precast Concrete CI.308
	Freeze-throw	CI.601 BS 1881 Pt.3				Durability test for aggregate not complying with moisture absorption requirements of BS 5337 CI.71.2
	Electrolytic Affluorescence					As required for salt containing aggregate or saline water
	Corea	BS 1881 Pt.4		BS 1881 Pt.4	BS 1881 para 114 with ref. To concrete at strength this specification	See Clause 306.2
ADMIXTURES	Compatibility with cement	As required by Laboratory				Tests to be carried out by independent Laboratory as required.

SECTION 4:

PIPEWORK

401.	Valves Pipes Fittings and other materials... ..	83
402.	Handling and Distribution of Pipes... ..	83
403.	Stockpiling and Storage of Pipes and Fittings... ..	84
404.	Proprietary joints and Couplings... ..	84
405.	Flanged and Bolted Gland Joints... ..	85
406.	Excavation of Trenches and Open Channels... ..	85
407.	Timbering or sheeting... ..	86

408.	Backfilling of Trenches	86
409.	Excavating and Backfilling trenches in 'Rock'	87
410.	Pipe laying General... ..	87
411.	Examination of pipes prior to laying... ..	87
412.	Laying and jointing pressure pipes.....	88
413.	Laying and Jointing Concrete Gravity Pipelines.....	90
414.	Concrete surround to pipelines.....	91
415.	Thrust and Anchor Blocks... ..	91
416.	Flotation of Pipeline... ..	91
417.	Fixing Valves and Penstocks.....	91
418.	Fixing Surface Boxes and Covers... ..	91
419.	Grouting in Ironwork... ..	91
420.	Proving Pipelines free from Obstruction.....	92
421.	Granular Bedding or Bed and Surround... ..	92
422.	Pipelines on Concrete... ..	94
423.	Flexibility in Pipelines... ..	94
424.	Testing pressure pipelines... ..	95
425.	Testing Gravity pipelines.....	96
426.	Painting... ..	97
427.	Manholes and Chambers.....	97
428.	Channels and Benchings.....	97
429.	Testing of Non-water-retaining structures... ..	98
430.	Fixing of Manhole and inspection Frames and Covers.....	98
431.	Fixing Step Irons and other Fittings... ..	99
432.	Pipes built in or through walls... ..	99
433.	River Crossings... ..	99
434.	Valves Penstocks etc	100
435.	Setting out of Lateral Drains and Junctions... ..	105
436.	Concrete Pipes and Fittings.....	106
437.	uPVC Pipes and Fittings.....	106
438.	Ductile Iron Pipes and Fittings.....	107
439.	Steel pipes and Fitters.....	107
440.	Precast Concrete Invert Blocks... ..	108
441.	Precast concrete paving slabs for open channels.....	109

PIPEWORK

401 VALVES PIPES FITTINGS AND OTHER MATERIALS

401.1 The Contractor shall supply all valves, pipes fittings and all other materials required for the proper execution of the Works in accordance with the Bill of Quantities.

Should it be necessary for the Contractor to supply additional valves pipes fittings or other materials besides those in the Bill of Quantities they shall

conform with the Specifications or other detailed Specification which may be prepared by the Contract Administrator.

402 HANDLING AND DISTRIBUTION OF PIPES

402.1 Loading unloading and handling shall be carried out using special lifting hooks with a curved plate to fit the curvature of the pipes etc. or webbing slings not less than 30 cm wide or other means approved by the Contract Administrator's Representative. Sheathed pipes shall only be transported on trucks or trailers fitted with approved padded timber cradles shaped to fit the curvature of the pipes and of adequate dimensions so as to prevent any damage to the pipe sheathing. Successive tiers of sheathed pipes shall be separated by similar suitable shaped timber cradles when more than one tier of pipes is being transported. Pillows shall be provided between securing chains or lashing when loads are being transported.

402.2 HANDLING AND DISTRIBUTION OF PIPES

402.1 Loading unloading and handling shall be carried out using special lifting hooks with a curved plate to fit the curvature of the pipes etc. or webbing slings not less than 30cm wide or other means approved by the Contract Administrator's Representative. Sheathed pipes shall only be transported on trucks or trailers fitted with approved padded timber cradles shaped to fit the curvature of the pipes and of adequate dimensions so as to prevent any damage to the pipe sheathing. Successive tiers of sheathed pipes shall be separated by similar suitable shaped timber cradles when more than one tier of pipes is being transported. Pillows shall be provided between securing chains of lashings when loads are being transported.

402.2 Particular care shall be taken during unloading, loading, handling and transportation to avoid distortion flattening denting scoring or any other damage to the piped fittings etc. and any damage to the external or internal coating sheathing or lining of the pipes fittings etc.

403 STOCKPILING AND STORAGE OF PIPES AND FITTINGS

403.1 When stockpiled shall not be stacked more than three tiers high without the Contract Administrator's prior approval. The pipes shall be stacked clear of the ground on timbers of adequate dimensions or prevent any damage to the pipes or to external sheathing or coating and successive tiers shall be separated by timber of similarly adequate dimensions with wooden wedges nailed to the ends of these timbers to prevent the pipes from rolling. UPVC pipes shall be adequately protected from direct sunlight to the satisfaction of the Contract Administrator.

403.2 Fittings etc. shall not be stacked more than one tier high and shall similarly be supported clear of the ground on timbers.

403.3 Pipe end covers wooden discs and other transit protections fixed by the pipe and other manufacturers shall be retained in place until the pipes etc. are inspected shortly before they're laid.

403.4 When pipes etc. are strung adjacent to the pipe trench prior to laying they shall be supported clear of the ground on suitable approved supports to prevent any damage to the pipes etc. or to external sheathing and coating and gaps shall be left at intervals and at well-defined tracks and roads to permit the free passage of livestock vehicles and persons.

403.5 Air valves rubber joint rings gasket bolts and similar fittings and materials shall be kept in approved locked premises and such fittings and materials shall not be distributed to the trench side until immediately prior to laying fixing jointing or assembly thereof. All rubber joint rings and gaskets must be stored in a cool damp location and all fittings and materials shall at all times be stored in the shade under cover and protected from the weather to the satisfaction of the Contract Administrator's Representative.

404 PROPRIETARY JOINTS AND COUPLINGS

404.1 The Contractor shall make himself and his employees acquainted with and comply with the instructions issued by the manufacturers of the various types of proprietary joints and couplings supplied for incorporation in the works. The Contractor shall be responsible for obtaining copies of any such instructions.

404.2 All tools and apparatus necessary for making the joints and protecting them shall be provided by the Contractor.

405 FLANGED AND BOLTED GLAND JOINTS

405.1 Flanged and bolted gland type joints shall be made with the joint rings and nuts washers and bolts provided. Two washers shall be used per bolt one under the bolt head and the other under the nut. The tightening of the bolts shall be evenly done all round by tightening be exerted on any nut or bolt spanners shall be of a suitable length but not exceeding 300mm from the axis of the bolt to the extremity of the handle.

405.2 Spanners shall not be lengthened in any manner in order to increase the purchase. After the satisfactory conclusion of the water tightness test all buried joints shall be wrapped using "Density" mastic and "Densyl" Tape manufactured by Winn and Coales, Chapel Road, London, S.E. 27, or other approved wrapping in accordance with the manufacturer's instructions. All exposed flanged joints shall be cleaned and given two coats of an approved bituminous paint.

406 EXCAVATION OF TRENCHES AND OPEN CHANNELS

406.1 Trenches for pipes and channels shall be excavated to the lines and levels shown on the drawings or as directed by the Contract Administrator.

Trenches for pipes shall have a width at the bottom of the trench equal to or less than the widths given in Table 4.1 below or as directed by the Contract Administrator. For concrete pipes the maximum trench width shall be the internal diameter plus 750mm.

**TABLE 4.1
PERMISSIBLE MAXIMUM TRENCH WIDTHS (uPVC PIPES)**

DIAMETER OF PIPE (mm)	MAXIMUM TRENCH WIDTH (mm)	MINIMUM TRENCH WIDTH (mm)
200 or LESS	750	500
300	850	600
400	950	700
500	1050	800
600	1150	900
700	1250	1000
800	1350	1100

406.2 Excavations for open channels, inlet or outfall drains, catch water drains, subsoil pipe drains, and French drains shall be to the widths and depths shown on the drawings of as directed by the Contract Administrator.

406.3 In the first instance excavation shall be to within 150mm of formation level and proper grade pegs shall then be set in the bottom of the trench by the Contractor for the accurate taking out of the rest of the excavation.

The bottom of trenches and open channels shall be excavated true to line and level and where pipes are to be laid without concrete beds holes shall be excavated under the joints to permit jointing. The bottom of the trench shall be smooth and free from stones and other projections

406.4 When directed by the Contract Administrator, such as in the excavation of trenches in an existing road, the Contractor shall carefully set aside the various materials encountered so that they may be replaced in their original position.

406.5 Trenches shall be kept clean and free from water during the excavation, laying of pipes and backfilling and the contractor shall dig diversion channels, erect coffer dams or otherwise dewater the trench.

406.6 Where, in the opinion of the Contract Administrator, any invert has become soft or unsuitable due to the Contractors method of working the Contractor shall at this own expense remove and replace the material with Class 15 Concrete or other imported material as directed by the Contract Administrator.

406.7 Where any trench or open channel has been over excavated below the invert required, the Contractor shall at his own expense, backfill the trench with Class 15 concrete or other imported material, as directed by the Contract Administrator.

407 TIMBERING OR SHEETING

407.1 The sides of trenches shall be supported, where necessary, by adequately shored and strutted timbering or sheeting, which shall be carefully removed when the trench is backfilled. The Contract Administrator may direct the timbering or sheeting be left in the trench.

408 BACKFILLING OF TRENCHES

408.1 No sewer or culvert shall be covered up until approved by the Contract Administrator.

408.2 Backfilling, where no concrete haunch or surround is called for, shall be of gravel material and/or selected fill material as directed by the Contract Administrator.

408.3 Backfill material around the lower half of the barrel of the pipe and in the joint holes shall be watered or dried as necessary mixed, and compacted to 100% BS. Selected fill materials shall then be laid in layers, not exceeding 0.15m loose thickness, watered or dried as necessary, mixed, and compacted to 90% BS and brought up uniformly on both sides of the pipe up to the top of the trench.

408.4 Timbering and sheeting shall be eased up 0.15m at a time in step with the backfill layer and compaction of 90% BS shall be obtained under such timber and sheeting.

409 EXCAVATING AND BACKFILLING TRENCHES IN “ROCK”

409.1 Trenches in “rock” shall be excavated as described in Clause 406 but in addition shall be excavated to such a depth that everywhere the rock surface is not closer to the barrel or socket of the pipe than 75mm.

409.2 In the particular case of concrete pipes the invert of the trench shall be backfilled and smoothed with Class 10 concrete, or other material, as directed by the Contract Administrator, so that the barrel or the pipes rests uniformly along its length and holes are left under the joints and sockets.

409.3 Trenches excavated in “rock” shall be backfilled as described in Clause 408 with imported material approved by the Contract Administrator.

410 PIPELAYING GENERAL

410.1 Pipes shall be laid true to line by means of a string line stretched along the sides of the pipes and true to level by means of a straight edge of at least 4 metres long kept inside the pipes and pulled forward to pegs boned in at suitable intervals between sight rails set to the proper levels.

410.2 Where pipes are to be laid on ‘normal’ or imported material the floor of the trench shall be compacted and shaped so that the barrel rests over a width of the least one third of its diameter and throughout the length of the barrel upon the floor. Holes shall be excavated under the joints and sockets so that the sockets do not bear on the ground. The underside of the barrel and socket shall then be packed hard with earth or gravel fill material as directed by the Contract Administrator and of maximum particle size not exceeding 25mm diameter and rammed solid. Refer to Clause 441 for the laying of uPVC pipes.

411 **EXAMINATION OF PIPES PRIOR TO LAYING**

Shortly before laying or fixing any valve pipe or fitting the contractor shall in the presence of the Contract Administrator’s Representative carefully examine each valve pipe and fitting as detailed in this Clause to ascertain damage or defect occasioned to the valves pipes and fittings during manufacture loading, unloading, handling and transportation. All damage and all defects revealed by this examination shall be repaired and remedied to the satisfaction of the Contract Administrator’s Representative.

411.2 The Contractor shall give the Contract Administrator’s Representative not less than 48 hours’ notice of his intention to examine any pipes etc. and the contractor shall not proceed to lay such pipes until they have been approved as free from damage and defects by the Contract Administrator’s Representative.

411.3 The ends of steel pipes and fittings shall be examined for circularity. Any distorted ends shall be corrected by an approved method to within the tolerances required by the mechanical couplings or other joints by which the pipes or fittings are to be jointed.

411.4 In the case of the internal lining of steel pipes any surface cracks and crazing shall be made good by lightly flaming the areas with a blow lamp or torch sufficient to cause the bitumen to flow and fill in the cracks. In the case of loose patches the lining shall be removed from the affected areas and the bare metal cleaned and primed with the bituminous paint. The area shall then be filled in with hot bitumen moulding mixture and the surface smoothed with a metal tool to produce a uniform finish.

411.5 If ordered by the Contract Administrator, the Contractor shall carry out inspection of the external sheathing of steel pipes with a “Holiday” detector immediately prior to laying and the contractor shall supply all necessary labour, tools, materials, and equipment for the carrying out of the “Holiday” detection test.

-
- 411.6 All ductile iron pipes and fittings which are severely dented or similarly damaged shall be discarded unless in the opinion of the Contract Administrator's Representative a portion of such pipe or fitting may usefully be salvaged in which case the contractor may cut off and discard the damaged portion only.
- 411.7 Asbestos cement pipes and fittings shall be carefully examined for cracks damaged ends and any other defects. All pipes and fittings which are found to be cracked or which have any defect which in the opinion of the Contract Administrator's Representative adversely affects their suitability for incorporation in the works shall be discarded. All damaged ends shall be cut off well beyond the damaged area and machined true.
- 411.8 All pre-stressed concrete pipes and fittings which may be damaged in the opinion of the Contract Administrator's Representative in such a way as to adversely affect their suitability for incorporation in the Works shall be discarded. Pre-stressed concrete pipes and fittings shall on no account be cut.
- 411.9 All concrete pipes and fittings shall be slung vertically and "rung" with a wooden mallet. Any damaged or cracked pipe shall be rejected.
- 411.10 After examination and any necessary repairs and attention all pipes fittings etc. shall be cleaned internally particular care being taken to ensure that no stones etc. are bedded in bitumen or coal tar linings.

412 LAYING AND JOINTING PRESSURE PIPES

- 412.1 Immediately before any new pipe is lowered into the trench the plug to be provided in accordance with this clause shall be removed from the end of the last pipe laid and the new pipe shall be carefully lowered into the trench with a crane or gantry operating within its designed working load or by other approved means.
- 412.2 Each pipe and fitting shall be laid true to alignment curve and gradient in accordance with the Drawings or as directed by the Contract Administrator's Representative. The minimum cover and the minimum gradient shall not be less than 0.6m and 1 in 500 respectively except by prior agreement with the Contract Administrator.
- 412.3 Where gradients are slack or where invert levels are shown on the Drawings or where required by the Contract Administrator's Representative the pipes shall be boned to even gradients and sight rails shall be provided for this purpose at intervals not exceeding 60m and at all changes in grade.
- 412.4 Long radius curves in the pipelines shall be negotiated by deflections taken up in the joints of one or more pipes. The deflection at each of the

various type of joint used in the Works shall confirm with the Manufacturer's recommendations and shall not exceed the following

Mechanical couplings	3 ⁰
Bolted gland or "Tyton" joints	2.5 ⁰
Joints on Asbestos Cement pipes	3 ⁰

412.5 Pipes laid underground in trenches shall be laid and firmly bedded on an even and uniform bed and if considered necessary by the Contract Administrator's Representative fine screened material shall be placed and consolidated in the trench bottom to provide such bed. Pipes shall not be dragged along the trench bottom. Joint holes shall be as small as possible and shall be filled in compactly after pressure testing and before the refilling of the trench is completed.

412.6 Where pipes are to be laid above ground on piers or bridges the piers and bridges shall be constructed true to line and level and the pipes shall then be laid thereon jointed and firmly secured thereto in the manner shown on the Drawings.

412.7 Pipes shall be jointed with the joints and couplings supplied and each type of joint shall be made in full compliance with the manufacturer's instructions. Special care shall be taken to ensure the absolute cleanliness of the pipe ends and joint components and only the lubricants recommended by the respective manufacturer shall be used. Should the Contractor require further quantities of joint lubricants or joints assemblies he shall supply them to the approval of the Contract Administrator's Representative and the Contractor shall bear the cost of supplying such additional lubricants or assemblies.

412.8 The Contractor shall take all steps necessary to ensure that no dirty water or other extraneous matter is allowed to enter the pipes during or after laying. In the event of dirty water or extraneous matter entering the pipes the Contractor shall immediately carry out the necessary cleansing as may be directed by the Contract Administrator's Representative. No extra payment will be made or allowed for such work.

412.9 Except when necessary for jointing the end of the last pipe laid shall be plugged to the satisfaction of the Contract Administrator's Representative and the Contractor shall provide a sufficient number of the use proper plugs for this purpose.

412.10 Pipe trenches shall not be refilled until permission to do so has been obtained from the Contract Administrator's Representative. Subject to such permission being obtained trenches shall be refilled without delay to at least the minimum extent required by Clause 424.3 hereof in readiness for pressure testing.

413 **LAYING AND JOINTING CONCRETE GRAVITY PIPELINES**

413.1 Rigid jointed pipes

Joints are to be made as detailed below. In all cases the joints shall be cured and protected from the wind, sun and rain by a covering approved by the Contract Administrator and shall be kept constantly damp for a period of at least 3 days. All pipes shall be saturated with water before jointing.

413.2 For spigot and socket pipes yarn soaked in cement grout shall be called into the socket to a depth of between 10 and 20mm. 1:2 cement/sand mortar shall be rammed into the socket and finished off with a fillet at an angle of 45°.

413.3 For pipes with ogee or butt joints the fuses shall be thickly covered with 1:2 cement/sand mortar and the newly laid pipes shall be driven hard up to the previously laid pipes. The outside of the joint shall be pointed up with a fillet of 1:2 cement/sand mortar 75mm wide and 25mm thick all the way round the barrel and central over the joint.

413.4 Flexibly jointed pipes

For flexibility – joined concrete pipes the rubber rings used are to be thoroughly cleaned and the joints are to be made in accordance with the manufacturer's instructions.

414 CONCRETE SURROUND TO PIPELINES

414.1 Where pipelines pass under streams and rivers or under roads the sections of pipeline under the stream river or road and for a minimum distance of 1.0m clear on either side of the bank or edge thereof or such greater distance as the Contract Administrator's Representative may require shall be surrounded with Class 15 concrete in accordance with the typical detail shown on the Drawings so as to provide a minimum 150mm thickness protective surround to the pipe.

414.2 Similar class 15 concrete surround shall be provided elsewhere as may be required by the Contract Administrator for the added protection of the pipeline at any point along the pipeline route.

415 THRUST AND ANCHOR BLOCKS

415.1 Concrete thrust and anchor blocks shall be formed at bends tees and valves in accordance with the typical sections shown on the Drawings or otherwise as directed by the Contract Administrator. The additional excavation shall be made after the bends etc. have been jointed and the concrete shall then be placed with all possible speed. The back of supports and blocks shall abut on to solid ground all loose material being removed before concreting.

415.2 The concrete used for thrust and anchor blocks shall be Class 15 and after placing shall be kept in view for not less than six hours. No pressure shall be applied in any section of main until the concrete has had at least three days curing.

416 **FLOTATION OF PIPELINE**

416.1 The Contractor shall be solely responsible for ensuring that flotation of the pipeline does not occur during construction. The extent of the backfill placed over each pipe after laying and before testing shall be such as will prevent flotation of the pipeline and the requirements of Clause 424.3 hereof shall not be construed as limiting in any way the extent of the backfill so placed or which may be so required.

416.2 Should any section of the pipeline float out of line or level the section of pipeline so affected shall be removed and re-laid in accordance with the Specification to the satisfaction of the Contract Administrator's Representative.

417 **FIXING SURFACE BOXES AND PENSTOCKS**

417.1 Valves penstocks and other fittings shall be securely fixed and where required extension spindles and headstocks shall be properly aligned and fixed in a vertical position. They shall be tested for ease of operation and water tightness and valve glands shall be repacked where necessary. Any damaged protective coating shall be made good and they shall be left clean in all respects.

418 **FIXING SURFACE BOXES AND COVERS**

418.1 Chamber covers and surface boxes shall be set in cement mortar to the correct levels camber and fall.

419 **GROUTING IN IRONWORK**

419.1 All brackets rag bolts and other ironwork for which holes have been boxed out or left in the concrete of structures shall be carefully grouted in to their correct positions in all particulars. The grouting in shall be carried out with cement and sand grout in such a manner that there shall be no apparent difference in the texture or colour throughout the face of the finished structure and there shall be no seepage of water either between the iron work and the set grout or between the set grout and the surrounding structure.

419.2 The above instructions shall apply also to the building in of pipes except that concrete of the class used for that part of the structure shall be used in lieu of cement grout.

420 **PROVING PIPELINES FREE FROM OBSTRUCTION**

420.1 After the pipelines have been completed and pressure tested satisfactorily in accordance with Clause 424 and 425 hereof the Contractor shall on the instructions of the Contract Administrator's Representative prove the pipeline free from obstruction.

420.2 Proving shall be carried out by means of passing through the pipelines a "badger" which must be kept in the pipes during the time they are being laid. The badger must be pulled forward and the obstructions removed immediately after the laying of each pipe and before the next one is placed in position so that the barrel of the pipe is left perfectly clean and smooth.

421 **GRANULAR BEDDING OR BED AND SURROUND**

421.1 Sand or granular bedding material shall consist of approved local sand or non-flaky broken stone or gravel, graded 20mm nominal size, which materials shall have a compaction fraction ascertained by the test method described below of not greater than 0.15. The Contractor shall provide all necessary testing apparatus for the use of the Contract Administrator's Representative on site. Frequency of tests shall be at the discretion of the Contract Administrator's Representative.

421.2 Before placing pipe bedding material the trench bottom shall be prepared and all loose stones or lumps of clay, rock projections, boulders and other hard spots removed. The approved bedding material shall then be laid over the full width of the trench to such depth that after the pipes have been laid to line and level, the thickness of bed beneath the barrel of the pipes is not less than 150mm or as otherwise stated in the Bill of Quantities or on the drawings. The bedding material shall be evenly spread and carefully compacted and where the bedding beneath the pipe exceeds 200mm in thickness it shall be placed and compacted in two separate equal layers. Any clay, large stones, and other unsuitable material falling onto or into the bed from the trench sides or from any other source shall be immediately removed.

421.3 Timbering or any other form of trench support should be withdrawn, whenever possible, as the bedding material is placed so as to avoid disturbance of the bedding by later removal

421.4 Pipes shall be laid and jointed as specified elsewhere. Any adjustments to line and level must be made by adding or removing bedding material under the body of the pipe and not by wedging and blocking. All hard objects or timber shall be removed before laying the pipes.

421.5 After the pipes have been laid correctly to line and level the bedding material shall be brought up to half diameter of the pipe and compacted as before and so as to prevent any voids under the pipe barrel and give uniform support all round. Care shall be taken not to disturb the pipeline from its approved position at this stage and as the subsequent backfilling of the trench proceeds as specified elsewhere.

421.6 For P.V.C. pipe and where sand or granular surround is billed, the pipe shall then be covered with bedding material compacted as before to a depth of 150mm above the top of the pipe barrel.

421.7 Where ground water conditions are such that the bedding material would be likely to act as a carrier for ground water from higher to lower ground, the Contract Administrator's Representative may instruct flow barriers of suitable selected earth to be inserted in lieu of bedding material. Such barriers to be erected at reasonable intervals close to flexible joints in the pipe, without alteration of the rate for bedding etc.

Compaction Fraction Test

Apparatus required

- 5
- i) Open-ended cylinder 250mm long and 150±5 mm internal diameter (150mm diameter pipe is suitable)
 - ii) Metal hammer with striking face 38mm diameter and weighing 1 kg.
 - iii) Rule

Method.

Obtain a representative sample* more than sufficient to fill the cylinder (viz. About 10kg). It is important that the moisture content of the sample should not differ from that of the main body of material at the time of its use in the trench.

Place the cylinder on a firm flat surface and gently pour the sample material into in, loosely and without tamping.

Strike off the top surface level with the top of the cylinder and remove all surplus material. Lift the cylinder up clear of its contents and place on a fresh area of flat surface. Place about one quarter of the material back in the cylinder and tamp vigorously until no further compaction can be obtained. Repeat with the second quarter, tamping as before, and so on for the third and fourth quarters, tamping the final surface as level as possible.

Measure down from the top of the cylinder to the surface of the compacted material. This distance in millimetres divided by the height of the cylinder (250mm) is the Compaction Fraction of the material under test.

*To obtain a representative sample, about 50kg of the proposed material should be heaped on a clean surface and divided with the spade down the middle into two halves. One of these should then be similarly divided, and so on until the required weight of sample is left.

422 PIPE LINES ON CONCRETE

- 422.1 Where a concrete bed to pipes is to be provided the excavation shall be taken out to the proper depth to receive the concrete and the pipes shall then be laid to line and level and jointed on precast Class '15' concrete blocks solidly bedded on the floor of the trench. When the pipes are jointed the trench bottom shall be cleaned and the concrete for the benching, haunching or surround as the case may be shall be carefully placed under and around the pipes, special care being taken to pack the concrete solidly under the pipes.
- 422.2 The concrete bed and protection shall extend along the length of the pipe to within 100mm of the joint collar and a gap shall be left adjacent to the joint. This gap shall be backfilled with selected excavated material.
- 422.3 All precautions shall be taken to avoid damage to the pipes during the placing of the concrete. The precast blocks shall be not less than 300mm x 150mm x 100mm and shall be notched to receive the barrel of the pipe and shall be placed immediately behind the joints.
- 422.4 For pipes of 600mm dia. and over, and on ground of soft formation, the concrete bed shall be cast in two layers. A bed of 50mm thickness shall be placed to receive the concrete blocks and after the pipes are jointed the remainder of the bed shall be cast.

423 FLEXIBILITY IN PIPELINES

- 423.1 All flexibly jointed pipelines shall be provided with additional flexibility between any structures, chamber, manholes, fixed points etc. and the remainder of pipeline.
- 423.2 Unless otherwise shown on the drawings the first joint shall not be more than 1.0m from the external face of the structure, chamber, manhole, fixed point etc. and the next joint shall not be more than 2.5m from the first joint.
- 423.3 The provision of the necessary short pipe lengths and additional flexible shall be included for in the rates for the pipeline.

424 TESTING PRESSURE PIPELINES

- 424.1 All pipelines shall be hydrostatically tested in the presence of the Contract Administrator's Representative after laying.
- 424.2 The Contractor shall give the Contract Administrator's Representative not less than 48 hours' notice of his intention to carry out a pressure test.
- 424.3 Before any pressure is applied to any pipeline each pipe shall be securely anchored and when in trench shall be covered for at least two-thirds of its

-
- length with not less than 60cm. Of the backfill material leaving the joints exposed. No joint shall be backfilled or moulded or covered in any way until after the satisfactory completion of the pressure test.
- 424.4 Pressure testing shall be carried out as the work proceeds in such lengths of pipeline as re convenient and meet the approval of the Contract Administrator's Representative. The ends of the length of pipeline under test shall be closed by means of caps or blank flanges. Pipeline sluice valves shall not be used for this purpose. All washout valves shall be fitted with blank flanges and the valves opened before the commencement of any pressure test. The Contractor shall be solely responsible for the provision of all caps and blank flanges necessary for testing of the pipeline.
- 424.5 The test pressure in the section of the pipeline to be tested shall be the test pressure head level shown on the Drawings or other pressure as directed by the Contract Administrator. The pressure in the pipeline shall be slowly raised to the test pressure the test pump disconnected and the pipeline left charged under pressure with all air valves open for a period of not less than 24 hours to allow air in the pipeline to be expelled and pipe linings and pipe walls of absorbent materials to become saturated.
- At the end of this period of time the test pump shall be reconnected and the pressure in the pipeline shall not be allowed to fall or rise more than 6m head of water below or above the test pressure and this shall be accomplished by pumping water into or releasing water from the pipeline as required. The volume of water pumped into or released form the pipeline shall be carefully measured. At the end of the test period of 24 hours the pressure in the pipeline shall be adjusted to the test pressure by pumping water into or releasing water from the pipeline as required.
- 424.6 The leakage from the pipeline shall be ascertained from the net volume of water that has been pumped into the pipeline during the test period of 24 hours. The leakage so ascertained shall not exceed the volume determined by the following formula.
- 3 litres per kilometre of pipe per 25mm. of nominal bore per
3kgf/cm² of pressure per 24 hours.
- 424.7 During the period of the pressure test all joints shall be inspected for water tightness. All signs of leakage or faults shall be remedied whether total leakage from the pipeline under test is less than the allowable leakage or not.
- 424.8 Should any length of pipeline fail to pass the pressure test the Contractor shall at his own expense carry out all work necessary to locate any remedy the faults and to retest the pipeline until it satisfactorily passes the test.
- 424.9 After the completion of pipe laying and installation of all fittings valves etc. the complete pipeline shall be subjected to a hydrostatic test under this test pressure the complete pipeline shall be inspected in the presence of the Contract Administrator's Representative and all faults revealed shall be remedied to his satisfaction.

-
- 424.10 The water used for pressure testing shall be provided by the Contractor and shall be free from impurities and of such a quality which will not pollute or injure pipelines and to the satisfaction of the Contract Administrator's Representative.
- 424.11 The Contract Administrator's decision shall be final in all matters relating to pressure testing.

425 TESTING GRAVITY PIPELINES

- 425.1 Gravity pipelines shall be watertight and shall not admit infiltration. They shall be tested by the Contractor in the presence of the Contract Administrator during the progress of the work at the completion of same and if so instructed immediately prior to payment of the retention money or at any time as the Contract Administrator may direct. The Contractor shall remedy and defective or leaky pipes, chambers, etc., and remove all dirt, silt or other matter of obstructions from them.
- 425.2 All gravity pipelines shall be water-tested under a minimum head of 1m or to twice the height of the maximum ground water level as decided by the Contract Administrator. In either case the pipelines shall be watertight. If permitted by the Contract Administrator they may be alternatively tested by air under an initial pressure of 100mm. head of water and the test of water and the test shall be deemed to be satisfactory provided that the loss of head is not greater than 25mm. in five minutes.
- 425.3 In every case the water used for testing the pipelines shall be left in the pipes until they are covered with earth or other trench filling material to a depth of at least 1.2m over the top of the pipes and until permission is given by the Contract Administrator for the water to be released. If after the Contract Administrator has approved of the pipelines and has given permission for the trenches to be refilled the pipes become damaged and lose water from any cause and/or admit sub-soil water the contractor shall have the pipes uncovered and the defect made good and the pipelines retested as before to the satisfaction of the Contract Administrator and all at the Contractor's sole expense.
- 425.4 The Contractor shall provide all water, labour, drain stoppers, bends, and other needful appliances for carrying out tests and no pipes or other work must be covered up until they have been seen and passed by the Contract Administrator. The Contractor shall allow for testing and all associated work in his pipe laying rates.

426 PAINTING

- 426.1 All pipes and fittings exposed to view shall be painted after making good the manufacturer's primer of shop coat with two coats of "Bitumastic Aluminium Solution D. 5909" manufactured by Wailes Dove Bitumastic Ltd., Hebburn, Country Durham, England, or other approved paint.
- 426.2 Steel Pipes and fittings in manholes or chambers shall be painted with two coats of "Bituros Solution" manufactured by Wailes Dove Bitumastic

Ltd., or other approved paint. Valves and surface boxes shall be similarly painted.

427 MANHOLES AND CHAMBERS

427.1 Manholes and chambers shall be constructed in accordance with the standard manhole detail drawings. Where the Contractor wishes to construct manholes or chambers other than in accordance with the said drawings he shall submit details to the Contract Administrator for his approval at least 14 days prior to the intended date of commencement of construction.

427.2 The incoming and outgoing lengths of pipes shall terminate at the internal face of the concrete with spigot ends which in the case of concrete pipes shall not be cut ends. The concrete surrounding the spigot ends shall be placed in the single operation to at least 150mm. over the top of the pipes for the full thickness of the wall and the whole of the base wall brought up to the same level. The concrete shall be of a minimum thickness of 40mm. between the pipe and structural floor and particular care shall be taken to ensure that the concrete completely fill the spaces beneath pipes and that a sound joint is made all round each pipe.

427.3 Access opening to manholes shall be sited on the downstream side of manholes unless another position is necessary for accommodating the rodding-eye of a backdrop.

Manholes and chambers are no necessary to be placed centrally over pipelines but shall be so located that the best use can be made of the area of the bottom of the manhole of chamber when arranging channels, particular regard being paid to backdrop.

428 CHANNELS AND BENCHES

428.1 Channels in manholes and chambers are to be formed in Class '20' concrete benching finished with 50mm, minimum Class '20' fine concrete or as directed by the Contract Administrator. The invert of the channel is to be formed to a fall not less than the lesser gradient of the two adjacent pipelines. All branch drains are to be connected to the main channel with half-channel branches of a proper angle and radius to lead into the run of the main channel the bends being as "slow" as possible.

428.2 Sides of channels and benchings are to be finished with 50mm thick Class '20' fine concrete and all shall be homogeneous. Special care shall be taken to produce perfectly smooth finish all over and to ensure the uniformity of the slope of the benching of the top of the nosing and of the invert and that proper clearance is given round valves, penstocks and other fittings.

428.3 Sides of channels shall be carried up vertically above the half round channel and shall join the benchings with nosings of 25mm. radius.

Benchings shall rise at a slope of one in six from the edge of the main channel starting from an assumed line between the crowns of the incoming and outgoing pipes. Inverts sides of channels and benchings of each manhole are to be completed before the chamber slab is placed in position.

429 **TESTING OF NON-WATER RETAINING STRUCTURES**

429.1 Manhole chambers and other non-water retaining structures shall be watertight. The Contractor shall if so required test them in the presence of the Contract Administrator.

429.2 The Contractor shall provide all water, labour, drain stoppers, bends and other needful appliance for carrying out tests and no work must be covered up until it has been seen and passed by the Contract Administrator. The test to be applied to chambers of manholes and other chambers shall be the filling of the chambers with water to 75mm. above the slab or to ground level respectively and after giving due time for saturation of the concrete shall be topped up to the original level. Thereafter the loss shall not be greater than the equivalent of 12mm, over the whole area of the chamber in 24 hours.

429.3 All covers and frames with recessed seating or which are close fitting have the edges thoroughly greased before the plug is put into the frame, if necessary all edges shall be re-cleaned and re-greased at the completion of the Works.

430 FIXING OF MANHOLE AND INSPECTION FRAMES AND COVERS

430.1 Before being incorporated in the work all manholes and inspection frames and covers shall be thoroughly including the removal of all grease and rust and shall then be coated immediately with an approved bituminous of other compound.

430.2 The frames of manhole and inspection covers shall be set in roads paths etc. so that the cover shall be flush with the surface of the road or path and elsewhere 250mm proud of the surrounding ground, one or more courses as may be required of concrete blocks shall be used to adjust the level of the frames and the whole shall be set in and on 1; 3 cement mortar.

430.3 All covers and frames with recessed seating or which are close fitting shall have the edges thoroughly greased before the plug is put into the frame. If necessary all edges shall be re-cleaned and re-greased at the completion of the works.

431. FIXING STEP IRONS AND OTHER FITTINGS

431.1 Step irons shall be of galvanised malleable irons and comply in all particulars to B.S. 1247.

431.2 All step irons shall be built in as the work proceeds and shall be staggered 300mm. apart horizontally and be 300mm apart vertically. The lugs on the underside of step irons shall only be permitted where it is impossible to build them in as the concrete is being cast.

431.3 When a valve or penstock is to be built into a manhole or chamber the necessary bolts and frames are to be placed in position of built in as the work proceeds.

432 PES BUILT IN OR THROUGH WALLS

432.1 Pipes shall be built in as work proceeds. Where this is not practicable or the Contract Administrator shall have given instructions to the contrary, pipes shall be built in subsequently. In such cases and where in particular pipes have rigid couplings care shall be taken in setting them to ensure that after the concrete has been cast around the pipes all adjacent pipes can be coupled up without strain on the joints. Care shall be also be exercised to ensure that puddle flanges are in the correct position.

432.2 Pipe work passing through walls for which holes have been boxed out shall be jointed completely and then tested before other pipes are finally concreted into the walls.

433 RIVER CROSSINGS

433.1 Payment for referenced river crossings will be made in accordance with the tendered rates for the respective works included in the relevant section of the Bill. The Contractor shall in addition be entitled to extra payment in the form of a single fixed lump sum for each of the referenced crossings which sum shall be deemed to be inclusive of all additional costs and expenses incurred or arising on account of river diversion works difficulty of access the handling and laying pipes etc. on piers the provision of scaffolding and all other matters or things which affect or influence the cost of completing each crossing and no variation in any of the fixed sums will be permitted on account of adverse weather conditions increased flow of a water in rivers and streams or any other thing resulting in the work being of greater difficulty or of longer duration than provided for by the Contractor.

434 VALVES, PENSTOCKS ETC

434.1 General

434.1.1 All valves and penstocks shall be the best of their respective kinds and shall be obtained from an approved manufacturer.

434.1.2 All sluice valve with extended spindles shall be provided with suitable indication to show that 'fully open' and 'fully closed' positions. This indication shall be easily visible from the operating position.

-
- 434.1.3 All flanges on all valves shall be BS 4622 type NP 16 unless otherwise stated.
- 434.1.4 All items of aluminium construction shall be isolated from concrete by the use of bituminous felt or D.P.C. material or two coats of bituminous paint. All aluminium shall be isolated from dissimilar metal by the use of fibre washers and spacers.
- 434.2 Sluice Valves
- 434.2.1 Sluice valves shall be double flanged unless otherwise specified and shall comply with BS 5150, 5151, and 5163 as appropriate. They shall be suitable for a maximum working pressure of 915 Kpa.
- 434.2.2 Each sluice valve shall have a drain plug fitted at the bottom of its seating so that accumulations of silt may be removed. Spindles shall be of the non-rising type and screwed so as to close the valves when rotated in a clockwise direction.
- 434.2.3 Valves shall be both open-end and closed-end tested.
- 434.2.4 All sluice valves shall have body marked with cast on or stamped lettering giving the following information:-
- (a) The manufacturer's name or trade mark
 - (b) The working pressure in metres head of water for which the valve is suitable.
 - (c) The nominal size of the valve in millimetres.
- 434.3 Check Valves
- 434.3.1 Check valves shall comply with BS 5153:1974 and shall be double flanged swing check valves with cast iron body having the following features:-
- (i) Detachable cover-plate of ample dimensions to facilitate inspection and withdrawal of the flap.
 - (ii) Cast iron disc to close on to gunmetal seats at an angle of not more than 80° to the axis of the pipe
 - (iii) An ample pocket below the flap into which may fall any solid matter which might otherwise prevent the flap from closing.
 - (iv) Suitable stops or other means to prevent the flaps from opening to an angle of less than 30° with the axis of the pipe.
 - (v) Hinged pin of gunmetal or stainless steel and extended on one side of the valve casing through a gunmetal bushed gland, and fitted with mild steel external lever.
 - (vi) Gunmetal drain plug fitted at the bottom of the body.

-
- 434.3.2 The maximum velocity through any check valve shall not be greater than 2.5 metres per second and they shall therefore be suitably sized to meet this condition.
- 434.4 Sludge Valves
- 434.4.1 Sludge valves shall be the screw operated type and have gunmetal faces, forged bronze spindles, gunmetal nuts, and bushes. The body, bridge, and door shall be in cast iron with the body of the valve terminating in a flange drilled to BS 4622 type NP 16.
- 434.5 Flap Valves
- 434.5.1 All flap valves shall be of flat-back, double hung type.
- 434.5.2 Flap valve frames and doors shall be of either best quality cast iron with gunmetal sealing faces and bronze hinge pins, or of aluminium alloy NP8 plate to BS 1477 and NE8 extrusions to BS 1474 with approved seating arrangements, hinges, fittings and fixings or of approved composite plastic construction.
- 434.6 Telescopic Valves
- 434.6.1 Telescopic valves or bell mouths, shall consist of high quality cast iron stand pipe with an easy sliding non-ferrous tube and cast iron discharge bell mouth or shall be approved plastic construction. The joint between the standpipe and sliding tube shall be sealed with a gland. The sliding tube shall be complete with guide rods.
- 434.6.2 The base of the standpipe shall be flanged to BS 4622 NP 16.
- 434.7 Hand stops
- 434.7.1 Hand stops and frames shall be of galvanised mild steel, aluminium alloy NP8 and NE8 or approved composite plastic construction. Doors greater than 300mm wide shall have two lighting handles. Aluminium and galvanised mild hand stops shall have nylon inserts or guides and neoprene seals.
- 434.8 Penstocks
- 434.8.1 All penstocks shall be of the fiat-back type and shall be watertight, when tested to 90 Kpa head and to reverse pressure as particularly specified.
- 434.8.2 Penstock frames and doors shall be of either best quality cast iron with two gunmetal faces, aluminium alloy NP 8, plate to BS 1474 or shall be of approved plastic construction.

-
- 434.8.3 An adequate number of cast iron wedges shall be provided on the doors and adjustable suitably faced wedge blocks as necessary fixed to the frame. The frame shall be of substantial construction.
- 434.8.4 All penstocks shall be provided with mild steel spindles screwed for clockwise closing and running in a suitable nut housed in the head gear which shall have a hand wheel or key for operation as indicated.
- 434.8.5 Suitable gearing or anti-friction devices such as ball-bearing thrust collars shall be provided as necessary to enable each penstock to be operated from the closed position by a 13kg 'push-pull' effort (total 26kg) at the rim of the handwheel or tee key. All penstocks fitted with headstocks shall be supplied with rising spindles except where otherwise indicated.
- 434.8.6 Where specified or shown on the drawings level invert penstocks shall be used and shall have a flush invert with adequate sealing arrangements.
- 434.8.7 Weir penstocks shall have a perfectly level sill and shall be complete with top seal unless otherwise stated.
- 434.8.8 All penstocks shall be supplied complete with all necessary nuts, bolts or studs and washers for fixing in position.
- 434.9 Headstocks
- 434.9.1 Any headstock required shall be of cast iron complete with a gunmetal index pointer working over a polished and graduated gunmetal indicator plate which shall be fixed to the side of the pillar. The pillar shall not be drilled for fixing. Bevel gearing, when required, shall be provided in a totally enclosed oil bath, or grease lubricated bevel gear housing.
- 434.9.2 Cast Iron footplate brackets shall be provided where indicated for penstocks of less than 0.3m² opening.
- 434.9.3 Galvanized Mild Steel flanged spacer tubes shall be provided where indicated and shall support the headstock from the penstock frame.
- 434.10 Hand wheels
- 434.10.1 All hand wheels shall be of best quality cast iron with completely smooth and rounded rims and marked thereon with direction of opening.
- All valves and penstocks shall open by an anti-clockwise rotation of the wheel or turnkey.
- 434.11 Extension Spindles
- 434.11.1 Extension spindles shall be of mild steel, sherardized or hot dip galvanized with the threaded portion left untreated.

-
- 434.11.2 Where indicated universal joints of approved type shall be provided to allow offsetting of the extension spindles.
- 434.11.3 Spindle lengths as given in the Bill of Quantities are measured from the inverts of the pipes or openings to the top of the squared end of the spindle or to the base of the headstock pillar as the case may be, unless otherwise indicated.
- 434.12 Guide Brackets
- 434.12.1 Guide brackets shall be of the cast iron split bearing type, and shall be built into the wall. The maximum spacing between brackets shall not be greater than 1500mm.
- 434.13 Key heads
- 434.13.1 Key-operated valves and penstocks shall be provided with cast iron caps to spindles.
- 434.14 Operating Keys, Spares and Special Tools
- 434.14.1 The Contractor shall include for operating keys, spares, and special tools. The spares shall suffice for 24 months operations. Operating keys shall be supplied for each key head up to a maximum of 6 No. in any one range.
- 434.15 Swivel Draw-off Arms
- 434.15.1 Swivel draw-off arms shall consist of a galvanized mild steel or approved plastic tube, cast iron bend and support pillar. The bend shall swivel on a watertight bronze or neoprene sealing gland at one end, a bronze pin fitted into the support pillar at the other. The cast iron support pillar shall be bolted to the floor of the tank or chamber.
- 434.15.2 The draw-off arm shall be raised or lowered by means of stainless steel cable operating over a gear winch, which shall incorporate a locking device, or by rising mild steel spindles with indicating capstan pillars as specified.
- 434.16 Fixing
- 434.16.1 All bolts, nuts, washers and foundation bolts with expanding shells shall be cadmium plated.
- 434.17 Testing
- 434.17.1 The performance of each unit shall be tested at the Supplier's Works in accordance with the conditions stipulated in the appropriate British

Standards and to the requirements of the Contract Administrator's Representative.

- 434.17.2 The acceptance by the Contract Administrator's Representative of equipment after testing at the Supplier's works shall in no way relieve the Contractor of his responsibility for the performance of the equipment after erection.
- 434.18 Air Valves
- 434.18.1 Single orifice air valves shall be of the single acting type for the automatic admission and discharge of either large quantities of air during main emptying or filling or small quantities of air under pressure during normal working conditions of the main.
- 434.18.2 Each single orifice air valve shall be complete with an isolating valve or cock.
- 434.18.3 Double orifice air valves shall be of the double acting type suitable for the automatic admission and discharge of bulk volumes of air during drainage and filling of the main, and for the release of small quantities of air during normal working conditions of the main.
- 434.18.4 Each double-orifice air valve shall be provided with a screw-down valve for isolating purposes. Isolating valves shall have gunmetal seats and stoppers and forged bronze spindles fitted with cast iron caps for key operation. The spindles of the isolating valves shall be screwed so as to close the valve when rotated in a clockwise direction. The isolating valves shall be suitable for manual operation against the maximum working pressure.
- 434.18.5 The design of the double-orifice air valves shall be such that the balls do not blow shut under any working or test conditions when large volumes of air are being released.
- 434.18.6 All double-orifice air valves shall be flanged. Flanges shall be faced and drilled and shall conform to the dimensions specified in B.S. 4504 tables for NP 10 unless otherwise stated.
- 434.18.7 All double-orifice air valves shall be supplied drilled with a 20mm. dia. hole tapped British Standard pipe. Thread suitable for fixing of a pressure gauge. Holes shall be fitted with a brass screwed plug and copper compression ring gasket.
- 434.18.8 Each air valve shall be suitable for the maximum working pressure stated in the Bill of Quantities.
- 434.18.9 Each air valve body shall be marked with cast-on or stamped lettering giving the following information:-

-
- (a) Manufacturer's name or trade mark
 - (b) Working pressure in metres head of water
 - (c) Size of air valve in millimetres
- 434.18.10 The air valves are likely to be exposed to tropical sun temperatures and the balls and other parts shall be suitable for these conditions.

434.19 FIRE HYDRANTS

- 434.19.1 Fire hydrants shall be designed and conform fully with B.S. 750 Type 2, with 'captive' internal valve.
- 434.19.2 Inlet flanges to fire hydrants shall be 80mm DN and be faced and drilled to conform to the dimensions specified in B.S. 4504: 1969 table. The outlet piece shall be screwed 2_{1/2} inch diameter B.S. 750 round thread.
- 434.19.3 The fire hydrants shall be capable of passing a minimum flow of 34 l/sec at a constant running pressure of 170 Kpa.

435 SETTING OUT OF LATERAL DRAINS AND JUNCTIONS

- 435.1 The Contractor shall ascertain and agree with the Contract Administrator's Representative full details of all junctions and laterals required, and this shall be done sufficiently far in advance of his sewer laying programme to avoid delay in the work.
- 435.2 The Contractor will be instructed in writing regarding the detailed requirements in connection with each lateral by the Contract Administrator's Representative and he is not to proceed with this work until such instruction has been received.
- 435.3 The position of the junction and the lines and levels of the lateral drains shall be so arranged as to allow the shortest practicable length of connections to be used.
- 435.4 Generally each lateral drain shall be 100mm in diameter but in cases where two or more houses are to be connected in combination the size may be increased to 150mm in diameter on the instructions of the Contract Administrator.
- 435.5 Each lateral shall be constructed at such a depth as to have a gradient not flatter than 1:60 throughout its length, and at the point of connection with house drains the invert level of the lateral shall be such as to allow of the house drains being laid at a gradient not flatter than 1:60. Where such a gradient is impracticable the particular case shall be referred to the Contract Administrator's Representative.

-
- 435.6 Wherever possible the upper end of each lateral shall be at a depth not exceeding 1.5m below road or ground surface level, but to accommodate low-lying properties and maintain the minimum depth may in particular cases have been exceeded.
- 435.7 Subject to foregoing of where no lateral is to be provided, a sewer junction laying at more than 1.5m below road or ground surface level shall have its branch brought up vertically to a level of approximately 1.5 below such surface.
- 435.8 The end of each lateral drain shall be left exposed until its exact position in plan and depth has been recorded and the record agreed with the Contract Administrator's Representative. A 50mm x 50mm creosoted wooden peg shall then be placed against the end of the drain to finish at ground level and, after the trench has been filled and compacted, a 1.2m long hardwood marker post shall be driven to project 100mm above ground level and this projection be painted white.

436 CONCRETE PIPES AND FITTINGS

- 436.1 Concrete pipes and fittings are to comply with BS 556 Part 2 (1972). They shall comply with the requirements of BS 556 for the particular class of pipes required to be used. Pipes and fittings shall be made with either ordinary Portland cement or with Sulphate resisting cement if this is called for in the Bill of Quantities. The internal dimensions shall be true and regular and the internal surface free from blemish.

437 uPVC PIPES AND FITTINGS

437.1 Pressure pipes

Unplasticised polyvinyl chloride pressure pipes and fittings shall comply with the latest revision of BS 3505 (1968) 'Unplasticised PVC pipe for cold water services' and BS 4344 Part 2 (1970), "Mechanical joints and fittings principally of unplasticised PVC'.

437.2 Gravity Pipes

Unplasticised polyvinyl chloride pipes and fittings shall generally comply with the latest revision of BS 5481:1977, 'Specification of uPVC pipe and fittings for gravity sewers' and B.S. 4660:1973, 'uPVC underground drain pipe and fittings'.

Pipes shall have a S.D.R. of 41 or 34

Class B pipes to B.S. 3505:1968, 'Specification for Unplasticized PVC pipe for cold water services' shall be acceptable for S.D.R. 41 pipes.

437.3 General

Each pipe and fitting shall be supplied with 1 No. flexible joint.

Flexible joints shall be either:-

- (a) of the unplasticised PVC sleeve or integral socket type and shall comply with BS 4355 Part 2 (1970)
- (b) Couplings of the Dresser, Viking Johnson or similar mechanical type providing they meet the requirement of Clause of this specification.

Solvent cement joints are not acceptable.

438 DUCTILE IRON PIPES AND FITTINGS

438.1 Ductile Iron pipes and fittings shall comply with the latest edition of BS 4772 (1971), 'Ductile Iron pipes and Fittings'.

Unless otherwise described all pipes and fittings shall be supplied with flexible joints of an approved type.

439 STEEL PIPES AND FITTERS

439.1 Standard of Manufacture

Steel pipes shall comply with BS 3601:19878 – *Steel Pipes and Tubes*, while fittings will conform to BS 534:1990 (dimensions) and AWWA C208-59 (reinforcing). Flanges will be to BS 4504:1989.

Flexible joints shall be by use of flexible coupling of approved pattern. Pipe for use with flexible coupling shall be true ended with pipe ends appropriately prepared for the type of coupling proposed.

439.2 Steel Grade, Minimum Wall Thickness, and Working pressures

The steel pipes shall be PN16 manufactured from steel grade B of yield stress not less than 235N/mm² and able to withstand working pressure up to 200 meters water column (i.e. 20 Bars).

The minimum wall thickness shall be as follows:

Pipe (N.D)	Minimum Wall
-------------------	---------------------

Diameter (mm)	Thickness (mm)
50	2.5
100	2.5

439.3 Internal and External Works Protection

Steel pipes shall be protected internally by a solvent free epoxy lining in accordance with AWWA C210-97.

The external protection of steel pipes shall be provided by a coating of fusion bonded epoxy to AWWA C213-96.

A polythene sleeve to ISO 8180:1985 shall be used during laying when specified to further enhance protection, and shall be of minimum thickness of 200 microns.

440 PRECAST CONCRETE INVERT BLOCKS

440.1 Precast concrete invert blocks for open channels shall be formed to the dimensions shown on the drawings. The concrete used shall be 15N/mm² concrete as described in Section 3. “Concrete Works”.

440.2 The excavation to receive the concrete invert blocks shall be shaped as indicated on the drawings or as directed by the Contract Administrator and thoroughly compacted before the channel is laid. The invert of the trench shall be accurately excavated to line and level

440.3 After the block is laid, soil shall be backfilled, watered if necessary, and compacted against the side of the block. Where directed by the Contract Administrator the block shall be jointed by thickly covering the joint face with 1:3 cement: sand mortar and driving the next block hard up against it. The excess mortar squeezed out of the joint shall be neatly troweled off to a smooth invert.

440.4 Where required by the Contract Administrator, the Contractor shall set up sight rails and shall bone in the block with a traveller.

440.5 All block ends shall be soaked with water for one hour before jointing and all joints shall be protected from the wind, sun and rain by a covering approved by the Contract Administrator and shall be kept constantly damp for a period of at least 3 days after forming.

441 PRECAST CONCRETE PAVING SLABS FOR OPEN CHANNELS

441.1 Precast concrete paving slabs for open channels shall conform to BS 368 and shall be 50mm thick.

441.2 The sides of the open channel shall be trimmed and recompact as necessary to allow placing of the slabs at a slope of 45⁰. Where directed

by the Contract Administrator the slabs shall be jointed to the invert block by thickly covering the joint faces with 1:3 cement and mortar and driving the slab up tight. The excess mortar supposed out of the joint shall be neatly troweled off to a smooth invert.

SECTION 5

BUILDERS WORK

INDEX

500	GENERAL	111
501	DAMP PROOFING	111
502	CEMENT.....	111
503	CEMENT MORTAR... ..	111
504	RENDERING... ..	112
505	BLOCKWORK.....	113
506	MASONRY... ..	114
507	BUILDING PAPER.....	114
508	PRECAST CONCRETE PATHS... ..	114
509	IRONMONGERY.....	114
510	PAINTING... ..	114
511	GALVANISED STEEL TUBES WITH SCREWED JOINTS	114

512	TIMBER.....	115
513	CARPENTRY.....	115
514	JOINERY.....	116
515	PRESERVATIVE TREATMENT OF TIMBER.....	116
516	PLUMBING.....	116
517	SANITARY INSTALLATIONS.....	117
518	METAL DOORS, DOOR FRAMES, WINDOWS ND LOUVRES.....	118
519	FLOORS.....	118
520	TERRAZZO.....	119
521	GRANOLITHIC FLOORING.....	119
522	PVC FLOOR TILES.....	120
523	WOOD BLOCK FLOORING.....	120
524	PVC FLOOR TILES.....	121
525	WOOD BLOCK FLOORING.....	121
526	PLASTERING.....	121
527	TYROLEAN FINISH.....	122
528	ROOFS.....	122
529	ROOF TILES.....	123
530	FLATROOF WATERPROOFING - PREPARATION WORK.....	123
531	FLATROOF WATERPROOFING - FILLING JOINTS.....	123
532	FLATROOF WATERPROOFING - TREATMENT.....	124

BUILDERS WORK

500 GENERAL

- 500.1 The Contractor shall construct the building as shown on the drawings in conformity with the Specification. Where any particular material, good, or method of fixing or construction is not specified the Controller shall seek the approval of the Contract Administrator.
- 500.2 The Contractor shall at all times use the best available materials and use only suitable and well established methods of construction, and shall ensure that the construction is in accordance with the Building Regulations of Kenya.

501 DAMP PROOFING

- 501.1 A bituminous damp proof layer shall be inserted in the walls in accordance with the drawings, and shall be a bitumen impregnated fibre complying with BS 743, to be not less than 150mm above the finished ground level.

-
- Before applying the DPC, all surfaces must be clean and free from dust, dirt, grease and loose material.
- 501.2 Bituminous damp proof courses shall be laid with laps of not less than 75mm and bedded solidly in cement mortar and with the exposed edges pointed.
- 501.3 A polythene vapour barrier shall be laid on the blinding to all floors which shall first be screeded with 25mm thickness of fine sand or as detailed on the Drawings. Joints shall be made with a suitable adhesive in a welded lap joint.
- 501.4 Alternatively the blinding may be given not less than four coats of a suitable bitumen emulsion to give a thickness of not less than 2 mm.
- 502 **CEMENT**
- 502.1 The cement used for mortar rendering grout screeding and other construction work shall be in accordance with the specified in Section 3.
- 503 **CEMENT MORTAR**
- 503.1 Cement mortar for blockwork, masonry, rendering, tiling, screeding, pitching and jointing concrete pipes shall consist of Ordinary Portland cement and natural sand mixed by hand or an approved mechanical mixer in the proportions by volume of one part cement to three parts sand. The cement and sand shall first be mixed dry until the cement colour can no longer be distinguished from the sand in any part of the mass and the whole shall then be uniformly wetted by approved means while undergoing further mixing. The water content shall be just sufficient to ensure a dense mortar of still consistency and adequate workability to permit trowelling or floating into place.
- The workability of cement mortar to be used for rendering may be improved by adding an approved plasticiser in the proportions recommended by the supplier of the plasticiser.
- 503.2 Mortar shall be prepared and used in such quantities that no more than 20 minutes shall elapse between first wetting and its completed use. Under no circumstances shall any mortar that has stiffened by commencing to set be used. Fresh mortar shall not be mixed with mortar prepared earlier and all batches shall be used entirely separately.
- 503.3 Sand for cement mortar to be used for rendering shall comply with BS 1199. Sand for cement mortar for all other uses shall comply with BS 1200.
- 503.4 Water used for cement mortar, rendering, grout, screeding and other construction work shall be in accordance with that specified in Section 3.
- 504 **RENDERING**

-
- 504.1 Surfaces to receive a finishing coat of rendering shall be thoroughly cleaned. Concrete surfaces shall be roughened by treating the formwork with an approved retarder and wire brushing after removing the formwork whilst the concrete is still green to form an adequate key. Alternatively concrete surfaces shall be treated with an approved cement bonding agent in accordance with the manufacturer's recommendation.
- 504.2 Rendering shall consist of cement mortar with an approved plasticiser used as and in the proportions directed by the manufacturers and approved by the Contract Administrator.
- 504.3 All surfaces shall be dampened as necessary and the rendering applied immediately afterwards. The rendering shall be applied in two coats of 20mm total thickness. The undercoat which shall have a thickness of 12mm shall be roughened to provide an adequate key for the finishing coat. A strip of expanded metal not less than 50mm wide and conforming to BS 405 shall be set in the undercoat at all joints between different surfaces being rendered (eg concrete/blockwork) and across all chases of electrical and similar services.
- 504.4 The finishing coat shall be applied with a wood skimming float and afterwards trimmed with a feather edge rule to a true and even surface. The surface shall then be thoroughly scoured with a hand float and any inequalities filled in. Overworking of the surface shall be avoided to reduce the tendency of surface crazing.
- 504.5 All rendering shall be protected from sun and rain by adequate and suitable coverings and the rendering shall be kept damp while setting. Any cracks or parts which sound hollow when tapped or other defects in the rendering shall be cut out and re-rendered.

505 BLOCKWORK

- 505.1 Precast concrete blocks for blockwork shall be solid blocks or hollow blocks manufactured from Ordinary Portland cement as specified for concrete in Section 3 and aggregates conforming to BS 882. All blocks shall be manufactured mechanically by compression and vibration. The mix used shall be not richer than one part cement to six parts of combined fine and coarse aggregate by volume. Blocks shall be dried for 24 hours after which curing shall start for a period of not less than 10 days. After curing all blocks shall be grouped carefully stacked and shall not be laid before 28 days after casting. All blocks shall be cast in clean moulds or accurate shape and dimensions. The tolerance on all dimensions shall be +/- 3mm and no membrane or web of any block shall be less than 40mm. Unless otherwise stated on the Drawings, solid blocks shall attain a strength not less than 3.5 N/mm² after 28 days and hollow blocks shall attain a strength not less than 3.0 N/mm² on the real area after 28 days.

-
- 505.2 All blocks shall be handled and stacked with care. The blocks shall be stacked protected from rain by a cover and in such a way that air circulates around them. No broken block or block of improper quality shall be used.
- 505.3 All blockwork shall be bonded pointed and uniformly bedded in true horizontal courses in cement mortar and built true to line and profile. Blockwork shall be carried up evenly and in regular stages and no part shall be raised more than 1m above any other part of work at any time. All blocks shall be well soaked before use and the top of unfinished walls wetted and raked back before work is recommended. All blockwork shall be built with vertical shall exceed 12mm thickness. Courses shall be properly levelled and perpendicular joints, quoins, jambs and angles shall be plumbed as the work proceeds.
- 505.4 Blockwork which is not to be rendered shall be finished with a fair face and the blocks shall be selected for even texture and unmarked faces regular shape and square unbroken arises. The blockwork shall be pointed as the work proceeds with a neat joint as required by the Contract Administrator's Representative. Where blockwork is to be rendered the joint shall be raked out 12mm deep as the work proceeds to form an adequate key.
- 505.5 Blockwork shall be bonded o concrete columns and walls by approved galvanized metal ties cast into the concrete spaced at alternate courses and extending not less than 150mm into the block joints.
- 505.6 In unreinforced blockwork the block cavities shall be filled with Class 20 fine concrete.
- 505.7 In reinforced blockwork the block cavities shall be similarly filled with Class 20 fine concrete and reinforced with steel bars as detailed on the Drawings.
- 505.8 Chases shall be cut as necessary for services but no excessive cutting will be permitted. Chases shall be made good after the erection of services by building in pieces of block or mortar.
- 506 MASONRY
- 506.1 Masonry shall be constructed from approved hard durable stone laid to bond. The stones shall be rough dressed so that the beds and sides are roughly perpendicular to the exposed face of the wall. The joints shall be 12mm thick on the average and completely filled with mortar. The face of the work shall be true to profile and the joints shall be neatly pointed in mortar.
- 506.2 Where the walls are to be rendered the joints shall be raked out to a depth of 12mm to form a key.

507	BUILDING PAPER
507.1	Building paper shall be of approved make. For concrete underlay work “sub-soil” quality shall be used and shall be laid with laps of 100mm minimum.
508	PRECAST CONCRETE PATHS
508.1	Precast concrete paving slabs shall be as specified in Section 3 of the Specification and shall be 600mm square and 50mm thick.
508.2	Precast concrete paving slabs shall be laid on a bed of sand 50mm thick and shall be joined in cement mortar. The Contractor shall lift and relay at his own expense any slabs which have sunk as a result of consolidation of the underlying fill or sub-base.
509	IRONMONGERY
509.1	Ironmongery of every description including manufactured articles shall be of the best quality and good design, strong and heavy and to the approval of the Contract Administrator’s Representative.
509.2	Brass, copper or gunmetal articles shall be fixed with brass or gunmetal screws, galvanised articles shall be fixed with cadmium plated screws and aluminium articles shall be fixed with aluminium or stainless steel screws.
509.3	All moving parts of ironmongery shall be properly oiled and left in perfect working order.
510	PAINTING
510.1	All painting shall be in accordance with Section 10 of the Specification.
511	GALVANISED STEEL TUBES WITH SCREWED JOINTS
511.1	All steel tubes and tubulars shall comply with BS 1387 and the joints shall be screwed in accordance with BS 21. They shall be “medium” class and shall be galvanised in accordance with BS 729 – Part 1. Fittings shall be in accordance with BS 143 and shall be galvanised.
511.2	Joints shall be made using good quality white hemp and boss white.
512	TIMBER

-
- 512.1 All timber shall be reasonably free from sap shakes large loose or dead knots waney edges or other defects and shall be dry and properly seasoned, with maximum 15% moisture content for joinery work and 18% moisture content for carpentry.
- 512.2 The qualities of timber shall be determined in accordance with the terms and definitions issued by the British Standards Institution. Materials and workmanship for structural timber shall comply with BS 5268: Part 2: 1984.
- 512.3 The constructional timber shall be Podocarpus or similar to the approval of the Contract Administrator's Representative and the best obtainable. Timbers shall be in long lengths and warped timbers will not be permitted. Timber shall be handpicked for roof members and any that have warped after collection shall be used for short length work or entirely rejected. Unless otherwise stated on the drawings, all structural timber shall be Grade 575.
- 512.4 The timber for joinery is to be approved quality Cedar well-seasoned and free from all defects.
- 513 CARPENTRY
- 513.1 The preparation of the timber shall begin with the main Works generally and shall be carried on continuously until all woodwork is prepared and stacked under cover on or near the site where it is to be used.
- 513.2 All carpenter's work shall have timbers of full scantling and lengths. Scarfing will only be allowed when necessary and in positions approved by the Contract Administrator. All timbers shall be left "from the saw" unless specified to be wrought.
- 513.3 The dimensions of timber shall be within 2.5% of the sized stated on the drawings and no extra payment will be made for timbers which exceed the dimensions stated.
- 513.4 The whole of the carpenter's work shall be framed and trussed in the best possible manner and fitted with all necessary wrought iron ties, staps, bolts, screws etc. as shown on drawings or as directed.
- 513.5 All shaving cuttings and other rubbish shall be cleared out and removed from premises where carpenter's and joiner's work is being carried on and every care shall be taken that no debris is left in the roof space.
- 513.6 Screws, bolts, anchors, clips, stirrups and other fastenings shall be of the best quality and proper dimensions to thoroughly secure the work in place. All screws, bolt heads and nuts shall be countersunk and the holes filled

with tightly fitting and matching plugs securely glued in place and matching the grain in the main work.

514 JOINERY

514.1 Joinery shall be framed together single or double tenoned, dovetailed or fitted with other proper and suitable joints whether these are shown on Drawings or described or not. All scribing mitreing stopped or fitted ends shall be worked as required.

514.2 All joiner's work shall be wrought and finished with a clean true smooth face. The dimensions given include 1.5mm for each wrought face.

514.3 Pannelled doors shall be framed with mortice and tenon joints and wedged with glued joints. Doors 50mm thick or over shall have two tenons in the thickness of the framing. The Contractor shall be responsible for obtaining the exact measurements of all openings.

514.4 Jambs, frames and architraves for doors shall be wrought hardwood. Jambs shall receive a prime coat of linseed oil paint before fixing and shall be fixed to the wall with at least 3 approved steel ties per jamb.

514.5 Internal doors shall be flushed (pressed) doors and shall be 45mm thick consisting of a 60 x 45mm hardwood frame braced with 35 x 35mm soft wood cross battens at 65mm centres and faced on both sides with 4mm thick plywood all glued with an approved adhesive. The doors shall be supplied complete with all door furniture, latch and 2No. x 76mm hinges.

514.6 Solid door frames and linings shall be prepared with styles morticed into the heads. The feet of all solid door frames shall have stout wrought iron dowels let into thresholds.

516 PLUMBING

516.1 Plumbing installations shall be carried out in accordance with best modern practice and shall be in all respect to the satisfaction of the Contract Administrator's Representative. The Contractor shall submit all plumbing details to the Contract Administrator's Representative for approval prior to commencing any installation. Plumbing installations shall be complete with all necessary appurtenances, whether detailed or otherwise, which are requisite for the proper functioning of the system.

516.2 The water service pipes within buildings shall be copper tubing with capillary type fittings, complying with BS 59. The tubing shall be fixed with approved clamps at intervals not exceeding 1 metre. The pipes shall be run neatly in vertical and horizontal lines.

-
- 516.3 All pipe runs within buildings shall be buried within the walls and before any plaster work is commenced. All pipe runs outside buildings shall be laid with not less than 300mm cover to finished ground level.
- 516.4 Each sanitary fitting shall be supplied by a separate feed pipe and unions shall be inserted to facilitate the disconnection and removal of each sanitary fitting. Unions shall also be inserted on each branch pipe where this joins a principal pipe.
- 516.5 The whole of the plumbing installation shall be tested at a pressure of 5 bar for a period of not less than 2 hours in the presence of the Contract Administrator's Representative. Any defect noted shall be made good and the test repeated to the satisfaction of the Contract Administrator's Representative. The Contractor shall be responsible for the provision of all necessary equipment, appliances, and labour for the testing of plumbing installations. Upon completion the Contractor shall leave all in perfect working order.
- 517 SANITARY INSTALLATION
- 517.1 All sanitary fittings, washbasins, urinals, water closets etc. shall be of the best quality and shall be obtained from a manufacturer to the approval of the Contract Administrator's Representative and supplied complete with all flush pipes, taps, valves, siphons, brackets, waste plugs and chains etc. of approved patterns.
- 517.2 "European-type" water closets shall be of white vitreous china complying with BS 1213 with "S" trap and shall include a low level white vitreous china cistern to BS 1125 close mounted to the pan and incorporating a wash down flushing system with a 12.5mm low pressure ball valve complying with BS 1212. Water closets shall be provided with plastic seat and cover.
- 517.3 "Asiatic-type" squatting closets shall be of white vitreous china complying with BS 121 with "S" trap incorporating a wash down flushing system with a high level white vitreous china cistern to BS 1125 with a 12.5mm low pressure ball valve complying with BS 1212. The water closets shall have integral footplates and an anti-splash rim for recessed installation.
- 517.4 Each water closet shall have a porcelain toilet paper holder fixed within the wall and adjacent to the water closet. The inlet to each water closet cistern shall be fitted with a 12.5mm stop valve complying with BS 1010.
- 517.5 Wash basins shall be of white vitreous china complying with BS 1188 and fixed to the wall by means of two steel brackets. Wash basins shall be supplied with chromium plated drains complete with rubber stopper and chromed metallic chain. Each basin shall be fitted with a 32mm diameter chromium plated siphon trap which shall be connected to the nearest floor drain, gulley trap or drainage pipe by a 50mm diameter galvanized pipe. Each basin shall be fitted complete with chromium plated tap for cold water.

-
- 517.6 All taps, mixers, stop valves and the like shall be chromium plated with metal handles and shall be manufactured by “Grohe” or similar approved.
- 517.7 All sanitary fittings shall be set level and true and shall drain away completely on emptying. They shall be fixed securely to floors and walls as appropriate and all protective paper shall be removed from concealed edges before fixing. All fittings shall be tested and adjusted to the satisfaction of the Contract Administrator’s Representative on completion.
- 518 METAL DOORS, DOOR FRAMES, BURGLAR PROOF, WINDOWS
AND LOUVRES.
- 518.1 All metal doors, door frames, and windows shall comply with BS 990 – Part 1 and shall have a rustproof finish to the approval of the Contract Administrator.
- 518.2 All louvres shall be of approved design and manufacture.
- 518.3 The Contractor shall be responsible for sorting windows and carrying to their respective positions, assembling composites, fixing lugs to the frames, placing windows in the openings, setting straight and plumb bedding all transomes and mullions in mastic cement and filling completely all interstices.
- 518.4 All door windows and louvre frames shall be built into the walls as the work proceeds unless otherwise permitted by the Contract Administrator’s Representative. Such permission shall not be granted if the frames are on site can be granted if the frames are on site or can be brought to site within a reasonable time.
- 518.5 The door window and louvre frames shall be fixed to lintels sills jambs and walls by means of screws or lugs which shall be pointed with mastic cement.
- 518.6 Fittings shall be wrapped and protected from damage until after rough trades have been completed.
- 518.7 Directly after fixing and before glazing, steel doors windows and louvres shall be thoroughly cleaned and painted with one coat of genuine red lead paint. After glazing but before the putty has set the final two coats of oil paint shall be applied.
- 519 FLOORS**
- 519.1 Floor finishes shall be of the type specified on the drawings, but shall not be laid until any equipment to be installed in a room has been installed.

519.2 After completion of all installation work all surfaces shall be thoroughly cleaned and all oil and grease removed before floor laying commences.

520 **TERRAZZO**

520.1 Terrazzo surfaces shall consist of hard marble chippings which shall be clean, granular, and free from dust, and a matrix of white cement (or tinted cement as required by the Contract Administrator).

520.2 12mm or 20mm grade chippings shall be used for flooring to give a high marble/cement ratio. The mix proportion shall be 3 parts of chippings to 1 part of cement.

520.3 Surfacing shall be laid 20mm thick on a 15mm minimum thickness layer of 1:3 cement mortar screed, which screed shall be laid on a sound, clean, rough surface providing a good key.

520.4 Before the screed is laid, jointing strips of ebonite or non-ferrous metal shall be laid to the Contract Administrator's satisfaction. No panel of flooring shall exceed 1.5m². Jointing strips shall be used at all walls, door openings, engine bases, etc.

520.5 A dry mix of the chippings and cement shall be thoroughly and carefully made to ensure uniformity of the finished work, and water shall be added in a fine spray whilst final mixing continues. The mixture when ready for laying should be plastic but should not flow too easily.

520.6 After the mix has been laid in floors it shall be tamped to ensure compaction and the surface lightly trowelled to obtain a flat surface but without bringing too much cement to the surface. In other surfaces the mix shall be adequately but not excessively trowelled.

520.7 After laying, the terrazzo shall be matured under damp conditions, and about three days later given a first grinding with coarse carborundum brick or disc using a good supply of water. After this grinding, surfaces shall be scrubbed with water to remove the slurry caused.

520.8 Any pores or holes shall then be grouted with a fine mix and five days later a second grinding shall be made with a finer grained stone or disc.

520.9 Finally, surfaces shall be washed with hot water and pure soft soap.

521 GRANOLITHIC FLOORING

521.1 The standard of materials and workmanship shall not be inferior to the recommendations contained in the current British Standards Code of Practice CP 204: Part 2 – In situ floor finishes, and where applicable shall be finished to match any existing flooring.

521.2 The granolithic flooring composition shall comprise of 1 part Ordinary Portland cement: 1 part dry fine aggregate: 2 parts dry coarse aggregate by weight. The amount of water added shall be the minimum necessary to give sufficient workability for laying and compacting. The aggregate shall comply with the requirements of BS 1201 for aggregate for granolithic concrete floor finishes.

521.3 The paving shall be laid in two layers to a total thickness of 50mm, and each layer shall be not less than 20mm in thickness. The paving shall be divided into areas not exceeding 15 square metres by using 3mm wide ebonite or non-ferrous metal dividing strips.

522 PVC FLOOR TILING

522.1 PVC floor tiles shall comply with BS 3261 and shall be not less than 2.5mm thickness and of an approved colour.

522.2 The tiles shall be laid, on a 30mm thick 1:3 cement mortar screed, in accordance with the manufacturer's instructions, and fixed with an approved adhesive

523 WOOD BLOCK FLOORING

523.1 Blocks for wood block flooring shall be of Kenya Cedar, kiln dried and free from torn or chipped grain, tool marks, and other defects. The thickness should be not less than 18mm, the width not more than 90mm and the length between 150mm and 380mm.

523.2 The wood blocks shall be laid on a 20mm layer of 1:3 cement mortar screed, finished level with a wood float, and shall be fixed with an aqueous bituminous emulsion adhesive.

523.3 After completion of laying the surface shall be rubbed down with an abrasive paper to remove all irregularities, finishing with a fine grade to leave the surface flush clean and smooth. Finally the surface shall be waxed and polished.

523.4 All other building operations should as far as possible be finished before the flooring is laid.

524 CONCRETE FLOOR AND WALL TILES

524.1 Concrete floor and wall tiles shall be of the dimension, type and colour indicated on the Drawings and shall comply with BS 1197: Part 2 – 1973.

-
- 524.2 The tiles shall be equivalent in standard and finish to “Cotts Tiles” manufactured by Mitchell Cotts (K) Ltd.
- 525 **GLAZED CERAMIC WALL TILES**
- 525.1 Glazed ceramic wall tiles shall be size 150 x 150mm produced by an approved manufacturer.
- 525.2 The tiles shall be gloss white in colour and shall be of first class quality free from cracks, bending, air bubbles, and scratches. Tiles shall be guaranteed against discolouring. The source and manufacture shall be approved by the Contract Administrator’s Representative and tiles shall comply with BS 1281 – 1974
- 525.3 Walls which are to receive tiles shall be given the first coat of plaster before tiling commences.
- 525.4 Tiles shall be soaked in water for at least 24 hours before tiling commences.
- 525.5 Tiles shall be bedded in a 1:3 cement mortar rendering 10mm thick with joints truly horizontal and vertical and of uniform width approx. 2mm. Sufficient mortar shall be used to fill all spaces between the tiles and the wall. After installation, joints shall be grouted with white cement mortar. All exposed tile edges shall be rounded. The last course of the tiles where tiles do not reach the ceiling shall protrude 5mm from the surface of the plaster.
- 525.6 Movement joints shall be for the full depth of the tiles and bedding. Back-up and filler materials shall comply with the recommendations of CP 202. The sealant shall be either be a two part polysulphide or two part polyurethane, and comply with Table 2 of CP 202.
- 526 **PLASTERING**
- 526.1 All plasters shall comply with BS 1191. Sand shall comply with BS 1098.
- 526.2 Lime shall be from a reputable source acceptable to and approved by the Contract Administrator. It shall be wet slaked to form lime putty and shall not be used within 24 hours of slaking.
- 526.3 The mortar for plastering shall be mixed on a clean boarded platform or in an approved mechanical mixer.
- 526.4 The undercoat shall be composed of two parts of approved anhydrous gypsum plaster, one part of lime putty and five parts of sand. The finishing coat shall comprise an approved plaster.

-
- 526.5 All concrete surfaces to be plastered shall be hacked or roughened by an approved method and as necessary to form an adequate key. All masonry or concrete block walling to be plastered shall be left with a roughened surface and the joints raked out. Any dubbing necessary to take out irregularities or surfaces shall be executed in the same plaster as the undercoat. Walls shall be wetted before applying the plaster.
- 526.6 Plastering to concrete surfaces or masonry and block work walls shall comprise one undercoat approximately 12mm thick and one finishing coat approximately 3mm thick to a total thickness of approximately 15mm.
- 526.7 The undercoat shall be properly scored or roughened to receive the setting coat and shall be thoroughly dried before the finishing coat is applied. The undercoat shall be accurately laid to form a true surface and the setting coat shall be finished to a fine smooth surface.
- 526.8 All types of plaster shall be cured in a damp state continuously for 10 days. Improper plaster shall be rejected whether due to cracked surfaces or improper finish and the Contractor shall cut out such defects and replace with good plaster. Mortar falling down on the floors shall not be reused unless collected on clean boards and used before its initial setting time.
- 526.9 Plaster shall have an even smooth surface without waviness and surfaces shall be at right angles to each other. Jambs, columns, beam edges etc. shall be rounded as directed and shall be straight vertically and horizontally.
- 526.10 Galvanised wire mesh of 12mm opening used for chicken pens shall be used in strips of at least 200mm in width to cover ducts of pipes installations, conduits, chases, joints and whenever required by the Contract Administrator's Representative. It shall be fixed with special nails, to serve as a carrier of plaster. Wire mesh shall also be used at all joints between different surfaces receiving plaster (e.g. concrete/block work). Metal corner beads of a shape approved by the Contract Administrator's Representative shall be placed on the corners and above the walls to keep plaster in place.
- 527 TYROLEAN FINISH
- 527.1 Tyrolean finish shall consist of 1 part Portland cement (tinted as required) to 2 parts suitable sand. The dry materials shall be thoroughly mixed together on a board, and then mixed with water in the proportion of 2 to 2.5 parts cement and sand to approximately one part water by volume. The mixture shall then be flicked on to the surface to be treated by means of a Tyrolean machine.

527.2 The finish shall be built up in three layers to a total thickness of 10mm. The work shall be done in the shade and where necessary screens shall be provided.

528 ROOFS

528.1 Pitched roofs shall be constructed in accordance with the drawings; timber and roof tiles shall be in accordance with the relevant specifications in this Section.

528.2 Flat roofs shall be waterproofed in accordance with Clauses 530, 531 and 532.

529 ROOF TILES

529.1 The tiles shall be Manson hart single lap concrete interlocking tiles complying with BS 550 or similar approved.

529.2 Tiles shall be laid at 300 mm gauge and 75 mm lap and nailed at every fourth course.

529.3 Ridge tiles shall be half round 457 mm long and shall be bedded and jointed in cement mortar. A 225 mm wide bituminous felt underlay shall be fixed under the ridge tiles.

529.4 Clear polythene sheeting of 500g thickness shall be laid immediately under the battens, with a minimum of 300mm lap at joints which shall run horizontally.

530 FLATROOF WATERPROOFING - PREPARATION WORK

530.1 The roof shall be screeded with a low workability 1:4 cement/sand screed laid in bays not exceeding 9 square metres in area with 1cm joints between the bays. The water content shall be the minimum necessary for handling and placing. The minimum fall and thickness shall be 1:80 and 40 mm respectively. The screed shall be brought to a smooth wood-floated finish. A 75 x 75 mm fillet or cove shall be formed at all right angled or near right angled intersections with parapet walls and the like. This shall be made from a mortar consisting of one volume of cement, 2 volumes of Colmastic 30.01* and 4 volumes of clean sharp sand.

530.2 Before any surface waterproofing treatment is carried out the concrete screeding shall be thoroughly cured and any cracks that may have occurred shall be made good.

530.3 The roof surface shall be thoroughly swept clean and all debris rubbish and dust removed.

531 FLATROOF WATER PROOFING - FILLING JOINTS

- 531.1 The joints between the bays of screed shall be thoroughly cleaned out and filled flush with a mortar consisting of 1 volume of cement, 2 volumes of Colmastic 30.01* and 4 volumes of clean sharp sand.
- 531.2 When the filling mortar has dried thoroughly, 300mm wide strips of Colas Membrane 88.10* shall be lightly nailed centrally along the joints prior to commencement of the waterproofing treatment. This sub clause shall also apply to the treatment of any movement joints in the roof where maximum movement is not expected to exceed 5mm.

532 FLATROOF WATER PROOFING - TREATMENT

- 532.1 The surface of the roof shall be swept clean to remove all dirt and dust which may have accumulated. The following waterproofing treatment shall then be carried out over the entire roof area and shall be extended not less than 250 mm up the inside of parapet walls (except for the slip sheet and the open woven glass membrane as stated below), and dressed over verges as indicated on the drawings.
- (i) The whole surface shall be primed with Colasprime 80.05* at a minimum rate of 0.13 litres/m².
 - (ii) Lay a slip sheet (Colas Membrane 88.11*) partially adhered (50%) by spot or line-bonding with Colmastic 21.06*, edges overlapped 80mm and bedded fully in the adhesive; this sheet shall be continued 120mm up parapets or vertical edges. Insert approved ventilators at not less than 6 m centres, each way. Allow the adhesive to cure overnight.
 - (iii) Apply a heavy brush coat of Colaskote 70.02* laid on in one direction. Allow to dry.
 - (iv) Apply a second heavy brush coat of Colaskote 70.02 laid on at right angles to the previous coat and immediately embed an Open Woven glass membrane, (Colas Membrane 88.08*), edges overlapped 80 mm. This membrane shall extend to 200 mm up the sides of parapets and vertical edges. Allow to dry.
 - (v) Apply a heavy brush coat of Colaskote 70.01* laid on at right angles to the previous coat of Colaskote 70.02. Allow to dry.
 - (vi) Apply a second heavy brush coat of Colaskote 70.01 laid on at right angles to the previous coat. Allow to dry.
 - (vii) Not less than 14 days after the final bitumen coat is dry, apply two coats of bituminous aluminium (Colaseal 71.04*), allowing the first coat to dry before applying the second. Apply at a rate of not less than 0/13 litres/m² for each coat.

* Obtainable from COLAS (EA), P.O. Box 46644, Nairobi.

SECTION 7

FENCING

205 INDEX

206 GENERAL REQUIREMENTS 136

207 CONCRETE POSTS FOR CHAIN LINK FENCING..... 136

208 CHAIN LINK FENCE... 137

209 BARBED WIRE FENCING ON WOODEN POSTS..... 138

210 GATES 139

700 GENERAL REQUIREMENTS

700.1 Erection

As soon as the Contractor is placed in possession of any part of the site he shall immediately erect fencing on the boundaries of the land where shown on the Drawings. In places where permanent fencing cannot be erected immediately, or where none is required, the Contractors shall, as directed by the Contract Administrator, erect, and when and where required re-erect and maintain temporary fencing as is necessary for the proper protection of the works.

700.2 Access

Provision shall be made in temporary fencing for Access, where directed by the Contract Administrator, for the use of owners, tenants and any other occupiers of the 'adjacent lands. Temporary fencing shall remain in position until it is replaced by permanent fencing or completion of the whole of the works unless the Contract Administrator permits its earlier removal.

700.3 Maintenance

All fences shall be regularly inspected and maintained, any defects being made good immediately they are noticed by or brought to the attention of the Contractor. The Contractor shall be responsible for all wear and tear of fencing howsoever arising until the construction of all other works has been completed, when the permanent fencing shall be handed over in sound condition, and the temporary fencing shall be removed.

700.4 Temporary Fencing

Unless specified otherwise on drawings or directed otherwise by the Contract Administrator, Temporary fencing shall be post and wire fencing to BS 1722 Part 3 Type SW 48 using plain wire and round wooden posts, or an alternative approved by the Contract Administrator which shall not be inferior. Where temporary fencing has to be removed temporarily for the execution of any part of the works it shall be reinstated as soon as possible and in the meantime the gap in the fencing shall be patrolled to ensure that no unauthorized crossing of the fence line occurs, and that no animal stock escape from adjoining lands.

701 CONCRETE POSTS FOR CHAIN LINK FENCING
701.1 Standard

In general all fencing is to be in accordance with BS 1722, Part I: 1963.

701.2 **Reinforced Precast Concrete Posts**

Concrete posts and struts shall be of Class 30 reinforced concrete, generally in accordance with Section 3 of the Specification. The course aggregate shall not exceed 10 m.

701.2.1 **Straining Posts**

These shall be 130 mm square in Section and 3.280 metres long overall with 600 mm top length cranked at an angle of 45 degrees to the vertical, slightly rounded at the external and internal cranked angles and also at the top end. The post is to be reinforced with 4 No. 8mm diameter mild steel bars bound by No. 12 SWG wire (2.64 mm diameter) stirrups placed at 150 mm intervals, and suitably holed for stretcher bolts or stirrup wires. The minimum concrete cover to the reinforcing bars shall be not less than 15 mm. The post will be notched twice to receive ends or raking struts. Two faces of the post will have two sets of galvanised mild steel angle iron cleats held by galvanised 25 mm x 4 mm GMS flatiron stretcher bar and GMS bolts and nuts.

The strainer posts shall be provided at all ends and corners, at changes in direction or acute variation in levels and at intervals not exceeding 70 metres in straight length of fence. The post shall be set in the ground to a depth of 0.75 m in a 450 mm square hole which is to be backfilled with Class 15 concrete.

701.2.2 **Special Corner Posts**

These shall be provided at all corners. The posts shall be 130 mm square, generally as straining posts, but the top cranked length and angle shall be altered to suit the corner angle to allow the barbed wire to run straight and level

The post shall be set in the ground to a depth of 0.75m in a 500 mm square hole which is to be backfilled with Class 15 concrete.

701.2.3 **Struts or Stays**

The raking struts shall be 100 mm square in section and 3.000 m long overall with one end splayed to suit the notch in the strainer post. The strut is to be reinforced with 4 No. 8mm dia. mild steel bars held by No.12 SWG wire stirrups placed at 130 mm intervals. The strut will be suitably holed for fixing by GMS bolts through the strainer post. The strut will be set in the ground in a hole 300 mm wide by 850 mm long by 750 mm with Class 15 concrete and the rest with good earth.

702 CHAIN LINK FENCE

- 702.1 The line shall be so erected that on completion it is truly on the boundary line of the plot. The top of the fence shall follow a general profile of the ground as agreed by the Contract Administrator. The fence shall be embedded upto a depth of 80 mm underground which will be graded to a general profile prior to the erection of the fencing.
- 702.2 Chain link fencing shall comply with BS 1722, Part 1, Clause 4 in general, and shall be of 50 mm galvanised mesh, not less than No. 10.5 SWG, and shall be Type LC 72.B.
- 702.3 Fittings for securing the fencing to the p.c.c. posts shall be in accordance with BS 1722, Part I, Clause 14 and shall be heavily galvanised.
- 702.4 Line wire shall be No. 9.5 SWG galvanised wire, and shall be attached and strained tightly to each straining post by means of winding brackets and to intermediate posts by a wire stirrup passed through a hole in the post. The top wire shall be secured 25 mm below the top and the bottom wire reasonably close to the ground. The intermediate wire shall be secured approximately midway between top and bottom wires.
- 702.5 Stirrup wire shall be No. 12.5 SWG galvanised wire
- 702.6 Tying wire for securing the chain link fencing to the line wire shall be galvanised No. 14.5 SWG.
- 702.7 Three rows of barbed wire shall be attached and stained to each straining post and secured with stirrup wire to holes in the cranked top of each intermediate post.
- 702.8 In general all chain link fencing shall be fixed according to BS 1722, Part I, Clause 22.

703 BARBED WIRE FENCING ON WOODEN POSTS

- 703.1 All timber used for fencing shall be well seasoned, straight grained red cedar.
- 703.2 Straining Posts shall be 2.60 m long and 150 mm in diameter. These shall be firmly embedded in ground and shall be provided at all ends, corners, and acute changes in direction or level, and shall be erected at intervals not exceeding 100 m in straight lengths of fences.
- 703.3 Struts shall be 100 mm in diameter and 3.0 m long secured to the straining post at an angle of 45° with a bird's mouth rebated joint spiked through with at least 2 No. 45 mm galvanised iron nails in previously drilled holes. The foot of the strut shall be sunk into the ground to a depth of 0.75 m and

the roots shall bear against the undisturbed ground. There shall be one strut to each line of wires leaving the post.

- 703.4 Intermediate posts shall be 2.40 m long and of 100 m diameter and either pointed at one end and driven into the ground to a depth of 0.60 m or sunk into the ground by excavating a hole and backfilling. These shall be provided at intervals of not exceeding 5 metres.
- 703.5 Droppers shall be 40 to 50 mm in diameter and 1.5 m long, threaded between wire strands at intervals not exceeding 5 m between strainer posts, except where intermediate posts occur.
- 703.6 The fence shall consist of six strands of wire spaced at 0.286 m intervals, the bottom strand being 0.30 m and the top 1.75 m from ground level or such other spacing as directed.
- 703.7 The top wire shall be No. 12 SWG two ply galvanised steel wire with four point barbs 150 mm apart. The lower 5 strands shall be either the same as the top wire, or plain No. 8 SWG galvanised wire, as set out in the Bill of Quantities. Binding wire, where used, shall be No.12 SWG galvanised and the stapled shall be 38 mm No.8 SWG galvanised. The wire shall comply with BS 1052 and the galvanising to BS 443. The minimum breaking strength for plain No. 8 SWG steel wire shall be 1110 lb. and for two ply 12 SWG barbed wire 950 lbs.
- 703.8 Each wire shall be strained tight by means of at least one ratched winder or other approved strainer and the end made fast by two complete turns round the strainer post and by two staples driven tight. Each wire shall then be attached to the intermediate post and dropper by a single staple or binding wire.

704 GATES

- 700.1 Gates shall be constructed to details shown on the drawings. All steelwork shall comply with the requirements of Section 9 of the Specifications.

SECTION 8 - DRAINAGE

INDEX

801	-	GENERAL.....	141
802	-	uPVC PIPES.....	141
803	-	CONCRETE PIPES AND FITTINGS.....	141
804	-	JOINTING CONCRETE PIPES	142
805	-	PIPES ON GRAVEL BEDDING.....	142
806	-	LAYING PIPES FOR SEWERAGE AND DRAINAGE.....	142
807	-	CONSTRUCTION OF CHAMBERS AND MANHOLES.....	142
808	-	INSPECTION COVERS AND MANHOLE COVERS.....	143
809	-	TESTING DRAINS, MANHOLES, ETC	143
810	-	RAINWATER PIPES AND GUTTERS	144

SECTION 8

DRAINAGE

801 GENERAL

801.1 All drainage works shall comply with the Building Code of the Republic of Kenya, and any local by-laws.

801.2 The Contractor shall bring to the Contract Administrator's attention in writing any part of the Works which he considers does not conform to such code or bylaws. If the Contract Administrator considers that such part of the Works does not so conform he will issue an instruction.

802 uPVC PIPES

802.1 Unplasticised polyvinyl chloride (uPVC) pipes and fittings for sewerage and drainage shall comply generally with BS 3506, Class "B" and shall be obtained from an approved manufacturer. Joints shall comply with BS 4346 - Part 1.

803 CONCRETE PIPES AND FITTINGS

803.1 Concrete pipes and fittings shall comply generally with BS 5911: Part 1 and shall be obtained from an approved manufacturer. The pipes and fittings shall have a smooth internal surface and the internal dimensions shall be true and regular and shall permit an even invert to be laid.

803.2 Before any length of pipe is laid all pipes shall be stood or slung vertically along the sides of the trench and be 'rung' with a wooden mallet. Any damaged or cracked pipe shall be rejected.

803.3 The bedding to and class of concrete pipes shall be suitable for the total external loads to be imposed on them, having consideration to the depth of cover, soil type, trench width and location. The Contractor shall determine the bedding type and class, full calculations shall be submitted to the Contract Administrator for approval before the pipes are laid.

803.4 Joints be of either rubber ring or spun hempen tarred yarn type.

804 JOINTING CONCRETE PIPES

804.1 Immediately before each pipe having a spigot and socket joint is laid a gasket of 12 mm spun hempen tarred yarn shall be looped around the spigot end which shall then be firmly pushed home into the socket of the preceding pipe. The yarn shall be cut to such a length as to form a butt joint at the top of the pipe. The yarn shall be caulked into the joint with a caulking tool particular care being taken to ensure that the spigot end is held truly central in the socket. A jointing mixture of cement mortar as

specified shall then be forced into the joint with the fingers. The compound shall be finished square with the end of the socket with a trowel. No joint shall be cemented until the gaskets of the next three joints in advance have been completed.

804.2 In the case of concrete pipes with ogee joints the joints shall be buttered with cement mortar before pressing the pipes together and then flush pointed internally and externally.

804.3 Any jointing material which gets inside the pipes when a joint is being made shall be removed by a “badger” which must be kept in the pipes during the time they are being laid. The badger shall be pulled forward and the surplus jointing material removed immediately after the laying of each pipe and before the next one is placed in position so that the barrel of the pipe is left perfectly smooth and clean.

804.4 Joints shall be cured by covering with sacking which shall be kept moist until the joints have completely set.

805 PIPES ON GRAVEL BEDDING

805.1 Unless otherwise dictated by the requirements of sub-clause 804.3, all concrete and uPVC pipes for drainage sewerage and ducts shall be laid on a 100 mm thick gravel bedding brought up to at least the horizontal diameter of the pipe. The bedding material shall consist of crushed stone or gravel passing an 11.2 mm sieve but retained on a 4 mm sieve mixed with coarse sand in the proportions of 2 parts of stone or gravel to 1 part sand.

805.2 Coarse graded gravel all-in ballast or screened selected excavated material may be used for the gravel bedding if it is of similar grading to that specified above and to the approval of the Contract Administrator.

806 LAYING PIPES FOR SEWERAGE AND DRAINAGE

806.1 Pipes shall be laid true to line stretched along the side of the pipes and true to level by means of a straight edge 4 m in length kept inside the pipes and pulled forward to pegs boned in at suitable intervals between sight rails set to the proper levels. All pipes shall be cleaned out as the work proceeds.

807 CONSTRUCTION OF CHAMBERS AND MANHOLES

807.1 Chambers and manholes shall be constructed as shown on the detailed Drawings in the locations shown on the drawings or as directed by the Contract Administrator.

807.2 Step irons shall be built into the walls as the work proceeds. Step irons shall be of galvanised malleable iron, complying in all particulars to BS 1247 and set at 300 mm centres vertically and 300 mm apart horizontally centre to centre.

807.3 Invert channels to chambers and manholes for sewers and drains (where used) shall be laid in precast concrete channels to the fall of the pipeline and jointed in cement mortar. All branch drains shall be connected to the main drain channel with half-channel bends of a proper angle and radius to lead with the run of the main drain channel, the bends being as “slow” as possible. The invert of the branch drain shall where possible be at least 80 mm above the invert of the main drain. Where it is found impossible to give a satisfactory lead with a precast concrete channel, the Contract Administrator’s Representative may direct the invert channel to be formed in concrete and rendered.

807.4 Manholes and chambers constructed of blockwork shall be rendered internally with 1:3 cement sand mortar. Manholes and chambers constructed of blockwork and protruding above ground level shall be rendered externally with 1:3 cement sand mortar to a depth of 200 mm below finished ground level. Manholes and chambers constructed of concrete cast in-situ shall be finished with fair faces and shall not be rendered.

808 INSPECTION COVERS AND MANHOLE COVERS

808.1 Manholes and chambers shall be fitted with covers and frames as indicated on the Drawings.

808.2 Heavy duty covers shall be fitted to manholes and chambers in roadways and in verges adjacent to roadway. Heavy duty covers shall be suitable for a wheel load of not less than 11 tonnes and shall be of the three point suspension non-rocking type.

808.3 Except where otherwise specified on the Drawings, medium heavy duty covers shall be fitted to manholes and chambers not subject to traffic loading. Medium duty covers shall be suitable for a uniformly distributed loading of not less than 70 kN/m² and shall be of the recessed steel type suitable for in-situ filling with concrete.

808.4 Covers fitted to manholes and chambers on sewers and drains shall be of the sealed type. The Contractor shall submit to the Contract Administrator’s Representative for approval full details of all inspection and manhole covers to be supplied.

808.5 All manhole and inspection covers shall be set in cement mortar or built into concrete slabs as shown or directed to the correct levels, cambers or falls.

809 TESTING DRAINS, MANHOLES ETC.

-
- 809.1 All drains and manholes shall be watertight and clean throughout and shall be tested by the Contractor under a minimum head of 1 m in the presence of the Contract Administrator's Representative during the progress of the work at the completion of same and if so instructed immediately prior to the payment of the retention money or at any time as the Contract Administrator may direct.
- 809.2 No pipelines or other work shall be covered up until they have been seen and approved by the Contract Administrator's Representative.
- 809.3 Should the pressure fall during test the Contractor shall locate the leaks and make them good after which the pressure shall be re-applied and the process repeated until the drains are satisfactory.
- 809.4 In every case the water used for testing the pipes shall be left in the pipes until they are covered with earth or other filling to the top of the trench or depth of at least 1.2 m over the top of the pipes and until permission is given by the Contract Administrator's Representative for the water to be released. If after the Contract Administrator's Representative has approved the pipes and has given permission for the trenches to be refilled the pipes become damaged and lose water from any cause and/or admit subsoil water the pipe shall be uncovered and the defect made good and the pipe retested as before to the satisfaction of the Contract Administrator's Representative.
- 810 RAINWATER PIPES AND GUTTERS
- 810.1 Asbestos-cement rainwater down pipes, fittings and gutters shall comply with BS 569.
- 810.2 PVC rainwater down pipes, fittings and gutters shall comply with BS 457.
- 810.3 Cast iron rainwater down pipes shall be of medium grade and comply with BS 460.

SECTION 9 -

STEELWORK AND MISCELLANEOUS FITTINGS

INDEX

901	MATERIALS.....	146
902	SHOP WORK.....	146
903	PROTECTION OF STEELWORK.....	146
903.1	Surface Preparation.....	147
903.2	Metal Coatings... ..	147
903.3	Painting... ..	147
904	SITE WORK.....	147
904.1	General.....	147
904.2	Handling, Stacking and Storing.....	147
904.3	Setting Out... ..	148
904.4	Security during Erection... ..	148
904.5	Base-plate Supports... ..	148
904.6	Cleaning of Steelwork	148
904.7	Erection... ..	148
904.8	Site Welding... ..	149
905	LADDERS	149
906	HANDRAILING.....	150
907	STAIRCASES.....	150
908	GUARDRAIL... ..	150

909	CHAINS.....	150
910	ACCESS COVERS.....	151
911	OPEN MESH WALKWAYS AND COVERS.....	151

SECTION 9 - STEELWORK AND MISCELLANEOUS FITTINGS

901 MATERIALS

901.1 All structural steel shall conform to the requirements of BS 4360, and shall be grade 43A for mild steel and Grade 50B for High Yield Steel.

901.2 Except where specified by the Contract Administrator, all bolts and nuts shall comply with BS 3692 except for High Strength Friction Grip bolts which shall comply with BS 4395.

901.3 Mild steel electrodes shall comply with the requirements of BS 639, and High Yield Steel with BS 2540.

902 SHOP WORK

902.1 Where requested by the Contract Administrator’s Representative two copies of all detailed fabrication drawings, erection drawings etcetera of structural steelwork shall be submitted for approval by the Contract Administrator’s Representative. Three copies of “as fabricated” drawings shall be submitted for issue to the erecting site, together with three copies of all bolt schedules and erection instructions.

902.2 All structural steel fabrication shall conform to the requirements of BS 153, except for fabrication for buildings which shall conform to BS 449. The use of High strength Friction Grip Bolts shall be in accordance with BS 3294.

902.3 All structural steelwork shall be fabricated using welded joints where possible for shop joints, and bolted joints for field assembly. Cleats for alignment and for connection shall be fitted to all stanchions at joints with

beams. All bolts and nuts shall be assembled with one washer under the head of the bolt and with another washer under the nut.

- 902.4 All steelwork shall be marked for identification of both the members and the joints. All members joined at one joint shall bear the same joint reference as the joints, as well as a separate member reference.

Markings shall be applied legibly and shall be such that it will be capable of withstanding all the effects of transportation, storage, and erection. Furthermore it shall be non-injurious to the painting or other surface protection system provided.

- 902.5 Bolts, nuts, washers and other small parts shall be packed in sacks or crates for dispatch to the site. All materials for each joint or set of joints shall be packed separately, such that no sack or crate weighs more than 50 kgs, and contains less than 100 bolts or other parts.

903 PROTECTION OF STEELWORK

All steelwork shall be protected in the following manner:-

- 903.1 Surface Preparation: Unless otherwise specified all surface preparation shall be by blast cleaning using compressed air, high pressure water, or airless methods. Cleaning shall normally be to second quality finish comparable with Swedish SA 2.5 standard. Abrasives shall be such as to produce a surface roughness in the steel not exceeding 4 mils (100 microns). Priming of the cleaned surface shall be undertaken within 4 hours of completing the cleaning process. (See section 10)

As an alternative to blast-cleaning, where appropriate, an approved pickling process (similar to the Footner Process) may be used. In this case a pre-fabrication primer shall be applied to the surface while it is still warm and after it has completely dried.

Where approved or otherwise specified, mechanical or flame-cleaning methods may be employed for surfaces which are not appreciably rusted. Cleaning shall be comparable to Swedish B.ST. 3 Standards.

- 903.2 Metal Coatings: shall comprise either hot dip galvanising conforming to the requirements of BS 729 Pt. 1 or spraying aluminium or zinc coatings conforming to the requirements of BS 2569 Pt. 1 as may be specified. In the case of hot dip galvanising the metal shall be applied at the rate of 2 oz/sq. ft (610 g/m²) of surface area in a uniform covering 4 mils (100 microns) thick. In the case of sprayed metal coatings the metal shall be applied to the previously blast-cleaned surface to give a covering of 4 mils (100 microns) nominal thickness.

For small items, such as bolts and threaded parts where metal coatings are specified, sheradising shall be carried out to give a covering of 1.2 oz/ft² (330 g/m²) of surface area.

903.3 Painting: All painting shall comply with the requirements of Section 10 of the Specifications.

904 SITE WORK

904.1 The Contractor shall be responsible for storage on site of all materials, and any necessary sorting, and for setting out the works, provision and casting in of all holding down bolts, bedding of base plates, erection, and field painting and any other work reasonably to be inferred from the Contract Document.

904.2 Handling, Stacking and Storing: Handling, stacking and storing shall be such that damage and undue stress will not be incurred by the steelwork. In this respect all steel beams stanchions and joints shall be supported on the major axis of the section. Transporting and handling of sections on their side is therefore prohibited.

Steelwork shall be stored clear of the ground soil to prevent contamination. All small items, including bolts, nuts, and washers shall be stored in a lockable container or room. All quantities of materials shall be checked against the schedule as soon as possible and any deficiency made up without delay.

904.3 Setting out: Positioning and levelling of all steelwork plumbing of stanchions and the placing of every part of the structure with accuracy shall be in accordance with the approved drawings and to the satisfaction of the Contract Administrator.

904.4 Security during Erection: During erection the work shall be properly bolted or otherwise fastened and braced as may be necessary to ensure that all loads occurring or likely to occur during the erection period whether from equipment, plant or wind are adequately provided for and this provision shall continue until such time the floor, structural walls or other permanent bracings or fixings are in position.

904.5 Base-plate supports: Prior to steel erection, all concrete foundations and supports for stanchion base-plates shall be checked for line and level, and holding-down bolts shall be properly located.

904.6 Cleaning of Steelwork: Base-plate surfaces and all steel-work shall be properly cleaned prior to erection. Surfaces to be brought into contact by HSEFG bolts shall be clean and free of rust, paint or grease or any other substance likely to impair the efficiency of the connection.

904.7 Erection: Permanent connections shall not be completed until as much of the structure as will be stiffened thereby has been properly aligned.

Bedding of stanchion bases shall not be carried out until a sufficient number of bottom lengths of stanchions have been properly lined, leveled, and plumed and a sufficient number of floor beams are in position to establish the accuracy of the work. Temporary steel wedges shall be used to support the stanchion bases one inch clear of the concrete support, and grout of sufficient fluidity consisting of 1:2 cement-sand shall be poured under a suitable head to fill completely and previously cleaned and prepared interspaces. Measures shall be taken for proper air venting to facilitate the grouting operation.

Bolts shall be tightened as the work proceeds.

Where HSFG bolts are used, each bolt and nut shall be assembled with one washer under the head of the bolt and with another washer under the nut. Tapered washers shall be correctly fitted and all nuts tightened against a surface normal to the axis of the bolt. Driving of bolts is not permitted. Nuts and bolts shall be tightened on a staggered pattern and where there are more than four in any one point; they shall be tightened from the centre of the joint outwards.

If, after final tightening, a HSFG nut or bolt is slacked off for any reason, the bolt, nut and washer shall be discarded and not used again. HSFG bolts may be used temporarily to facilitate assembly during erection provided they are not fully tightened to the specified torque condition. The use of drifts shall be restricted to work required to match fair holes and shall not be permitted to distort or enlarge them or damage the surfaces. Where holes are clearly out of alignment, the matter shall be reported to the Contract Administrator for his decision as to what remedial action to adopt. Where instructions are given to enlarge the hole this shall be carried out by reaming.

Cutting of members shall not be permitted except where instructed by the Contract Administrator.

904.8 Site Welding: Site welding where indicated on the Drawings shall be carried out by the metal-arc process. It shall be undertaken by skilled welders and shall conform to the requirements of recognized good practice. The Contract Administrator's Representative may require welders to be tested in accordance with a suitable recognized standard, in which case only approved welders shall be allowed. Where applicable the welding of open-web steel joints to beams shall be carried out only to ensure a sufficient means of movement. Welding of bridging rods shall be sufficient to prevent lateral displacement and buckling during the concreting operations.

905 LADDERS

-
- 905.1 The sides of the ladders shall be 62 x 10 mm mild steel flats set 400 mm apart and the ends of the sides shall be bent and cranked at suitable angles for taking off from the walls and floorings. The sides shall be drilled to receive the rungs spaced at 250 mm intervals.
- The rungs shall be 20 mm dia mild steel bars and shall be fixed to the sides by offering them into the holes and fixing with a 4 mm fillet weld which shall be taken all round the perimeters of the bars.
- 905.2 The stays for the ladders shall be 25 x 10 mm mild steel flats built at least 100 mm into the concrete of the supporting structure. The built- in ends of the stays shall be split and bent to give a good hold in the concrete. The ladder shall be fixed to stays with 10 mm bolts. The stays shall be not more than 2 metres apart vertically.
- 905.3 All ladders rising 2500 mm or more shall be fitted with safety hoops. The hoops shall have a diameter of 760 mm and be of 50 x 8 mm flats at no more than 900 mm centres, fixed to the stringers and with three vertical straps 50 x 8 mm flats extending from the top to the bottom hoop.
- 905.4 The ladders and the stays shall be thickly galvanized after manufacture. After erection ladders shall be painted with 2 coats of approved bituminous aluminium paint.
- 906 HANDRAILING
- 906.1 Hand railing shall comprise the following items as shown on the drawings:-
- (a) Stanchions to hold handrails, at a maximum of 2m intervals
 - (b) Handrails at 0.5 m and 1.0 m above floor level
 - (c) Face plates for building into concrete
- 906.2 Stanchions shall be fabricated from steel hollow box sections, or from black iron water pipe, or otherwise as shown on the drawings. The ends of the stanchions shall be sealed against the ingress of moisture by steel plates welded on. Hollow box sections or black iron water pipe shall be used for handrailing or as shown otherwise on the drawings. The minimum wall thickness of the sections used for stanchions and rails shall be 3 mm. The stanchions shall be flanged for bolting to concrete or steelwork.
- 906.3 Hoops shall be welded on where required for fixing guard chain.
- 907 STAIRCASES

-
- 907.1 Staircases shall be suitable for a superimposed load of 5 kN/m^2 calculated on the plan area of the stair.
- 907.2 Open mesh type flooring shall be used for the treads and on the landings, and it shall comply with the clause on open mesh walkways.
- 907.3 Stairs and landing shall be guarded on each side with a continuous handrail which shall be between 840 mm and 1000 mm in height on stairs measured from the tread nosings, and 1000 mm high on landings. Hand railing shall comply with the clause on hand railing.
- 908 GUARDRAIL**
- 908.1 Guardrail shall be 750 mm in height with a single top rail. In all other respects it shall comply with the specification for hand railing.
- 909 CHAINS**
- 909.1 Guardrail shall be 750 mm in height with a single top rail. In all other respects it shall comply with the specification for hand railing.
- 910 ACCESS COVERS**
- 910.1 Access covers and frames shall be fabricated from standard steel sections and chequer plate as shown on the Drawings, to the dimensions shown on the drawings. They shall be weatherproof (prevent the ingress of water) when closed, and shall in all respects be strong and durable.
- The minimum thickness of all materials shall be 3 mm.
- 910.2 The covers shall be lockable in accordance with details shown on the Drawings.
- 910.3 The covers and frames shall be galvanized.
- 911 OPEN MESH WALKWAYS AND COVERS**
- 911.1 Open mesh type walkways, platforms and covers shall be of aluminium or galvanised steel, suitable for a superimposed load of not less than 5 kN/m^2 .
- 911.2 The walkways, platforms and covers shall include all necessary supports not detailed on the Drawings.
- 911.3 Open mesh panels shall be trimmed with full depth nosing bar along all edges and bolted to each other when in place to help ensure a firm

walkway. Panels shall be cut in such a way and fixed so as to provide a continuity of pattern.

911.4 Covers shall incorporate a hinged and lockable open mesh access panel with an 750 x 750 mm clear opening, strong, durable hinges and heavy duty non-corrodible padlock. Openings for valves keys shall be just sufficient in size for the valve key and shall incorporate a hinged cover only.

911.5 All panels shall be securely bolted to the supporting structures. Where the supporting structure is concrete, galvanised mild steel angle curbs shall be provided and securely grouted into rebates left in the concrete such that the tops of the panels are flush with the top of the concrete.

SECTION 10

PAINTING

INDEX

GENERAL.....	153
BLOCKWORK... ..	153
WOODWORK... ..	154
METALWORK... ..	154
STRUCTURAL STEELWORK.....	155
GALVANISING.....	157
MACHINERY AND ELECTRICAL.....	157
FINISHING OFF.....	160

SECTION 10 - PAINTING

1001 GENERAL

- 1001.1 The contractor shall supply all paints, primers, varnishes, distemper, oil, etc. ready mixed in original sealed containers bearing the brand maker's name identifying the contents and giving directions for its proper use.
- 1001.2 Painting materials shall be of the best quality products of recognized manufactures, and shall be subject to the approval of the Contract Administrator. The quality of the finishing colours shall be capable of giving three year's minimum satisfactory performance under tropical conditions with high temperatures and humidity, and capable of withstanding temperatures of up to 60⁰C for long periods without colour change. Paints shall also be resistant to oils, acids, and alkalis.
- 1001.3 All surfaces to be painted shall be adequately cleaned and prepared to the satisfaction of the Contract Administrator's Representative and shall be dry and free from any oils, greases, stains or other marks prior to being painted. The paint shall be well and evenly applied. Where sprays are used, markings of the edges of the painted area shall be carried out to provide a definite edge. Brushes and sprays shall be correct size and type for the work being executed.
- 1001.4 For painting done in several coats each coat shall be of a different shade or colour from the others. Each coat shall be allowed to dry thoroughly and sufficiently harden before the next coat is applied.
- 1001.5 All colours shall be selected and approved by the Contract Administrator's Representative.

1001.6 All hardware and furniture for doors and windows, together with any exposed electrical installation in walls shall be removed before painting commences. Upon completion of all paintwork all such hardware and furniture etc. shall be re-installed and left in good working order.

1001.7 Floors shall be covered as protection against staining by paint.

1002 BLOCKWORK

1002.1 Surfaces of concrete and rendering to be painted shall first be washed down and then allowed to dry. Any efflorescence present shall be thoroughly removed, and the areas so affected shall be given a coat of porous alkali-resistant primer. After any traces of grease have been removed the surfaces shall be painted with two coats of emulsion paint of the copolymer acrylic type. Any cracks in walls shall be cleaned, filled, and puttied up then left to dry before application of paint.

1002.2 Plastered surfaces shall be left as long as possible to dry out before being painted and after any efflorescence has ceased to form and has been removed, they shall be painted with two coats of an approved porous emulsion paint. When a gloss paint finish is called for, this coat or coats should only be applied over the emulsion paint after an interval of at least six months.

1003 WOODWORK

1003.1 Woodwork to be painted shall be reasonably dry and its surfaces shall be cleaned and made smooth by the use of fine sand paper obliquely across the grain. The surfaces shall then be dusted off with a dusting brush.

Knots shall be sealed with knotting putty to BS 1336, unless very resinous, when they shall be cut out and the depressions filled after priming. The work shall then be thoroughly primed by brush with a priming paint to BS 2521, end grain being given two coats. Cracks, holes and open joints shall be stopped with a mixture of equal parts of hard stopping and linseed oil putty.

Two coats of undercoating of approved manufacture shall be applied, the surfaces being rubbed down between coats. The surfaces on being dry shall then be painted with a final coat of gloss paint leaving no brush traces or irregularities.

1003.2 Hardwood surfaces shall not be painted but shall instead be treated with two coats of linseed oil, of the clear boiled type. The linseed oil shall be well rubbed in, until the surface of the wood is clearly capable of not absorbing any further linseed oil. The second coat shall be applied between 8 and 12 days after the application of the first coat.

1004	METAL WORK
1004.1	Galvanised metal surface shall first be treated with one coat of mordan solution which shall in due time be carefully washed off. The surface shall then be primed with a calcium plumbate primer. When this has dried thoroughly, the surfaces shall be given one coat of undercoat and one of a gloss finishing paint.
1004.2	All metalwork shall be cleaned free from all rust, scales, grease oils and any other surface stains, and shall be given one coat of an approved primer compatible with the metal to be painted, two applications of undercoat and one application of a gloss finishing coat. The Contractor shall seek specific instructions to paint any non- ferrous metal surface.
1004.3	All metalwork which has been supplied with bituminous protection of painting prior to dispatch from the place of manufacture, such as pipes, tubes, valves, manhole covers etc., shall have all exposed surfaces painted after erection. The manufacturer's primer or coating shall be made good to the same standard and specification as supplied, and shall then be given two coats of paint as follows:- (a) Pipes, valves, manhole covers, and fittings etc. exposed to view shall be painted with two coats of an approved "bitumastic aluminium paint" or similar approved paint. (b) Pipes, valves, and fittings e.t.c. in manholes, or chambers shall be painted with two coats of Bitumastic paint or other approved paint.
1005	STRUCTURAL STEELWORK
1005.1	Shop painting : Painting shall not be undertaken when the temperature is less than 3 ⁰ C or when the Relative Humidity is greater than 85% Contract surfaces to be connected by high strength friction grip bolts shall not be painted. Where surfaces are subsequently to be welded, galvanising, metal spraying, or shop painting shall be terminated* within 75mm of the areas to be welded. Machined surfaces shall not be painted, but shall be protected against corrosion by means of a rust-inhibiting coating which can be easily removed on site or is not detrimental to the jointing condition if left in position. Other steel surfaces which, prior to dispatch are to be brought together in permanent contact with each other, shall after cleaning be primed and the work bolted up while the paint is still wet. Finishing paint shall be applied to the connected joint. (Sub-Clause 1005.2).

* This does not apply to pre-fabrication primers.

Unless otherwise specified all painting with the exception of the final finishing coat, shall be carried out in the shops.

1005.2 Protective Paint systems: The following sub-clause establishes the requirements for normal work. Where a particular Specification relating to any particular work is in conflict with this sub-clause the requirements of the particular Specification shall prevail

Immediately after cleaning, those surfaces which have been prepared by blast-cleaning or pickling shall be treated with an approved pre-fabrication primer. After fabrication, a zinc-rich primer (the metallic content of which shall not be less than 85%) shall be applied in one coat. Finishing coats (one of which shall be applied on site) shall consist of the following:-

For normal conditions – a high build system – consisting of two coats of chlorinated rubber or epoxide-resin paint shall be applied in equal thickness of 5 mils (125 microns) each.

For submerged or partially submerged conditions a high build paint system shall likewise be used, but shall consist of two coats of epoxy-pitch paint of similar thicknesses.

Those surfaces which have been metal coated, and are required to be painted in addition shall first be treated with a coat of an approved pre-treatment primer. This primer shall be such that its phosphoric acid content has been adjusted for etch-priming purposes. This shall be followed by the coat of zinc-chrome primer. Unless otherwise specified the finish shall consist of two coats of lamellar-pigmented paint, either micaceous iron oxide or aluminium as directed, except where aggressive, submerged or partially submerged conditions prevail, when the finishes shall consist of two coats of epoxy-pitch paint applied in equal thickness of 5 mils (125 microns) each.

The surfaces which have been mechanically or flame-cleaned shall be brush-primed with one coat of red lead or calcium plumbate paint and finished with two coats of micaceous iron oxide or aluminium paint as directed.

1005.3 Site Painting : All surfaces to be painted shall be dried and cleaned free of all oil, grease, dirt or other extraneous matter by the use of which spirit, water or other extraneous matter by the use of white spirit, water or other appropriate cleaning material. Where surfaces have been damaged in transit they shall be made good to the same standard to which they were originally protected. Where as a result of such damage the metal has been bared, the paint immediately adjacent to the affected area shall be trimmed down, the affected area cleaned by wire brushing and the protective paint system restored, to provide a coat by coat lapping at the junction of the

new and old paint system applied similar to that of the surrounding steel surfaces.

Where surfaces have been left unpainted and are to be connected by High Strength Friction Grip bolts they shall be cleaned as specified above and the contact surfaces brought together without further treatment. After bolting up, those surfaces which, being exposed are not protected, shall be wire brushed, primed and painted to the requirements of Clause 1005.2 to give a coat by coat lapping with adjoining painted surfaces.

Where surfaces have been left unpainted and are to be completely embedded in concrete they shall be cleaned of all oil, grease mill scale or other extraneous matter immediately prior to concreting but shall otherwise be left untreated. Where steelwork is to be partially embedded in concrete the paint system shall be continued into the concrete for a distance equal to the least lateral dimension of the concrete forming the surround.

Unless otherwise specified the final coat of finishing paint (Clause 1005.2) shall be applied to the immediate area of all steelwork connections after completion of erection, in which case any damage sustained during the course of erection shall be made good to the satisfaction of the Contract Administrator. Painting will not be permitted when the temperature is below 3⁰C or when the Relative Humidity is in excess of 85% or during wet weather.

1006 **GALVANISING**

1006.1 Galvanising shall be hot dip galvanising conforming to the requirements of BS 729 Part 1. Galvanising shall be applied at the rate of 610 g/m² of surface area in a uniform covering or 100 microns thickness.

1007 **MACHINERY AND ELECTRICAL EQUIPMENT**

1007.1 The Contractor shall obtain from the Contract Administrator details of colour requirements before commencing his painting and shall submit for approval the name of the paint supplier and details of the paint offered.

1007.2 Preparation and Priming before Delivery to Site.

-
- (a) Steel and iron casting shall be thoroughly cleaned and degreased with a suitable solvent. The prepared surface shall then be lightly blasted and then immediately primed with one coat of approved epoxy zinc-rich primer to an average dry film thickness of 0.04 mm.
- (b) Bright metal parts not normally painted and spindle threads etc. shall be protected by coating with two coats of approved colour lacquer or similar compound. Spindle threads shall be further protected against damage in transit by a wrapping of inert material. Bolts and nuts shall generally be electro-galvanised or sheradised.
- (c) Galvanised items and non-ferrous metals shall be thoroughly degreased by wiping down with white spirit and given one coat of an approved etch primer compatible with the paint system. The first coat of the specified system shall be applied not more than four hours after the primer.
- (d) All fabricated steelwork surfaces shall be thoroughly cleaned and de-greased with a suitable solvent. Heavy rust scale shall be removed by chipping and scrapping. The prepared surface shall then be grit blasted to a quality defined by photograph comparison reference SA 2.5 Swedish Standard SIS 05 59 00 and finally all dust removed. The surfaces shall then immediately be given one coat of an approved etch primer compatible with the paint system. The first coat of the specified system shall be applied not more than four hours later.
- (e) All electrical distribution switchgear and control panels etc. shall be prepared as follows:-
- (i) For use in external or damp conditions
- Castings shall be prepared as (a)
- Fabricated steelwork shall be prepared as (d)
- Galvanised items and non-ferrous metals shall be prepared as ©
- (ii) For dry internal conditions
- The surfaces shall be adequately de-greased and rustproofed.

1007.3 Painting before Delivery to Site

All prepared items of steel castings, cast iron, galvanised articles, non-ferrous metals, structural and finished steelwork shall be given the following shop painting after priming:-

(a) Equipment for use in external or damp conditions:

(i) Above Water Parts

Shall have one coat of approved High Build Thixotropic Chlorinated Rubber Paint of selected colour applied to a minimum dry film thickness of 0.125 mm.

(ii) At or below water parts

Shall have two coats of approved High Build Epoxy pitch applied to a finished dry film thickness of 0.10 mm minimum per coat. The first coat shall be chocolate colour and the final coat black, unless otherwise specified on the Drawings.

(c) Equipment for use in dry internal conditions

(i) Electrical distribution switchgear and control panels etc. which are normally painted to finish at the maker's works:

One undercoat and two coats of approved cellulose paint to completion.

(ii) All other equipment:

Shall have one coat of approved High Build Thixotropic Chlorinated Rubber Paint of selected colour applied to a minimum dry film thickness of 0.125 mm.

1007.4 Painting after Delivery to Site

(a) All damaged and defective preparation, priming, and protection shall be made good. Before painting the equipment all grease shall be removed with solvent and all foreign matter removed by washing and rinsing with water.

1007.5 Final painting shall be as follows:-

(a) External Equipment

(i) Below water parts

All nuts, bolts, and bolt holes shall during assembly be coated with an additional clear lacquer coating applied either by spray, brush, or dip-treatment, in order to protect

the metal where damage may occur to previously applied coatings during assembly.

(ii) Above water parts

Shall have one finishing coat of approved High Thixotropic Chlorinated Rubber Paint of selected colour applied to a minimum dry film thickness of 0.125 mm.

(b) Internal Equipment

All items previously primed and given one finishing coat at Contractor's Works shall be given a further finishing coat of an approved Thixotropic Chlorinated Rubber Paint in selected colours. The total dry film thickness of the final coat shall be less than 0.125 mm.

(c) Bright metal parts shall be cleaned and polished and given two coats of colorless protective lacquer.

(d) Where it is not possible to obtain with reasonable expediency, proprietary units such as motors, gear-boxes, etc. which adhere to this paint specification the Contractor shall inform the Contract Administrator or his Representative and then proceed as follows:-

- Such units shall be rubbed down to remove the existing paint finish and to form a suitable key.
- The equipment shall be de-greased with solvent and all foreign matter removed by washing and rinsing. Two finished coats shall then be applied as (a) (i) or (iii). Before the application of the above finishing coats, tests shall be carried out to ascertain if solvents in the subsequent coats of paint will react and cause 'lifting' to the existing. This shall be done by applying by brush a small quantity of the appropriate finishing coat thinners. Should lifting occur, it will be necessary to first protect the existing paint with a suitable barrier coat.

(e) Special Protective Systems

For components in contact with corrosive chemicals such as acids, lime ferrous sulphate or aluminium chlorohydrate and where the above protection system is unsuitable the Contractor shall put forward such protection as he shall deem necessary and shall detail his offered system with his Specification.

1001.1 All surfaces including window panes shall be left clean and doors and windows hinges lubricated.

SECTION 11

ELECTRICAL INSTALLATION

INDEX

1101	GENERAL.....	162
1102	REGULATIONS.....	162
1103	ELECTRICITY SUPPLY.....	162
1104	TEST ON COMPLETION.....	162
1105	CIRCUIT BREAKERS	162
1106	DISTRIBUTION BOARDS.....	162
1107	LABELS AND CIRCUIT LISTS.....	163
1108	CABLES AND WIRING.....	163
1109	CABLE INSTALLATION.....	164
1110	CONDUITS	164
1111	SITE LIGHTING.....	165
1112	EARTHING	165
1113	DRAWINGS	165
1114	LIGHTNING CONDUCTOR.....	165

-
- 1101 **GENERAL**
- 1101.1 This specification comprises the supply and installation of all site lighting, distribution boards, and all associated wiring at the sites.
- 1102 REGULATIONS**
- 1102.1 The whole of the installation shall be carried out in accordance with latest edition of the Institution of Electrical Contract Administrators (Great Britain) Regulations for Electrical Equipment in Buildings and to the regulations of the local electricity supply authority, i.e. KP&L Co. Ltd.
- 1102.2 In the case of conflict between the various electrical regulations, the regulations of the local electricity authority shall take precedence.
- 1103 ELECTRICITY SUPPLY**
- 1103.1 A 240 volt single phase 50 Hertz electricity supply will be available from a single pole moulded case circuit breaker mounted in the main switchboard.
- 1104 TEST ON COMPLETION**
- 1104.1 On completion of the separate parts of the installation the Contractor shall carry out tests on the installations in the presence of and to the satisfaction of the Contract Administrator's Representative.
- 1104.2 The following tests shall be made:-
- (a) Earth continuity on each circuit and sub-circuit installed.
 - (b) Insulation resistance to earth.
 - (c) Polarity of switches and continuity of ring main circuits
 - (d) Potential drop at various points on the installation.
- 1105 **CIRCUIT BREAKERS**
- 1105.1 Circuit breakers shall be of the miniature or moulded case pattern and shall comply with BS 3871.
- 1106 DISTRIBUTION BOARDS**
- 1106.1 All distribution boards shall be of folded sheet steel construction which shall, if required be braced for rigidity.

-
- 1106.2 Access to distribution boards shall be from the front by hinged doors gasketed with an approved material to form a dust proof seal and secured with cam type fasteners.
- 1106.3 Cable and conduit entries shall be made through glands in plates covering both top and bottom of the distribution board.
- 1106.4 All external fixing screws etc. shall be corrosion resistant.
- 1107 **LABELS AND CIRCUITS LISTS**
- 1107.1 The engravings on labels and inscriptions on circuit lists shall be to the approval of the Contract Administrator's Representative.
- 1108 **CABLES AND WIRING**
- 1108.1 The Types of cables used shall be selected with due regard to economy and efficiency and shall be manufactured in accordance with the following British Standard:-
- (i) BS 6005 PVC Insulated Cables (non-armoured) for Electrical Power and Lighting.
 - (ii) BS 6207 Copper Sheathed Cables for Electricity Supply.
 - (iii) BS 6346 PVC Insulated Cables for Electricity Supply.
 - (iv) BS 6480 Impregnated paper Insulated Cables for Electricity Supply - Part 1.
- 1108.2 Cables shall be tested in accordance with the above mentioned standards.
- 1108.3 Cables shall be coloured in accordance with the International standard practice to denote phase and neutral.
- 1108.4 All cables laid in the ground shall be armoured and laid in GMS pipe ducts if under roads.
- 1108.5 Armoured cables other than those laid in the ground shall be suspended on racks cleats or cables hangers and shall be arranged for bolting to steelwork, brickwork, stonework, or concrete as may be required.
- 1108.6 All other wiring shall be threaded through conduits either surface mounted or chased into walls.
- 1108.7 Cables shall be terminated with compression type glands which shall be suitable for the conditions under which they will be installed. Glands used for armoured cables shall include provisions for sealing the armour wires to prevent corrosion.

1108.8 Wiring shall be carried out in polyvinyl chloride (PVC) insulated wires in a neat and systematic manner.

1109 **CABLE INSTALLATION**

1109.1 All Cables buried in the ground shall be laid on 75 mm of sifted and compacted earth in a trench excavation to a minimum depth of 750mm.

1109.2 After installation the cable shall be covered with 75 mm of sifted and compacted earth, the trench then being back-filled in the normal way.

1109.3 Cable tiles to protect cables laid in ground and cable marker posts shall be provided and placed in position by the Contractor.

1109.4 Care shall be taken not to damage or cut the cable during installation.

1109.5 Excavation for the cable trench will be carried out by the main Civil Contractor and adequate notice will be required from the electrical sub-Contractor to ensure that delays are not encountered.

1110 CONDUITS

1110.1 Conduits and conduit fittings including junction boxes shall be of extruded PVC (polyvinyl chloride) and shall comply with BS 4607 Part 1, Type A. They shall be of rigid construction with high impact resistance and maintaining their resistance under the climatic conditions prevailing in Nairobi and around. A separate earth conductor shall be run in the conduit to enable satisfactory continuity to be obtained.

1110.2 Conduits shall be free from any rough edges and approved insulating bushes with rounded edges shall be fitted in the ends of the conduits prior to drawing in cables. The internal diameter of the conduit shall be such that the cables can easily be drawn in and any cable withdrawn and replaced by another cable of equal size without disturbing the remainder.

1110.3 Conduit fittings and junction boxes shall be of rigid construction and all box covers shall be secured by suitable non-corrosive screws.

1110.4 Conduits shall be neatly fitted in position, brought round angles by means of inspection bends or elbows and shall be fitted to walls by means of cleats screwed to plugs of adequate size.

1110.5 Conduits and fittings for each circuit shall form a complete draw-in and draw-out system and shall be fitted and connected up complete before any cables are drawn in.

1110.6 Conduit systems shall be erected so as to avoid, as far as possible, the condensation or retention of moisture within them and in such a manner as to prevent ingress of insect, etc.

1110.7 All conduit runs, junction boxes, etc. shall be carefully sited to the approval of the Contract Administrator's Representative, due allowance being made for accessibility, inspection and maintenance as far as possible diagonal runs are to be avoided, all branches being taken off at right angles.

1111 SITE LIGHTING

1111.1 Site lighting shall be provided to illuminate the building frontage areas at night and shall comprise of four to six ground level spot lamps installed behind the pavement wall

1111.2 A combination of colours shall be chosen to reflect Mitchell Cotts Logo colours whilst remaining compatible with the building colour.

1111.3 Site lighting shall be controlled by photo-electric cells, but shall have provisions for manual over-rides.

1112 EARTHING

1112.1 All items of electrical equipment installed under this contract shall be earthed to the Contract Administrator's satisfaction.

1113 DRAWINGS

1113.1 The installations will be shown on sketches to be provided by the Contract Administrator or as directed on site by the Contract Administrator.

1114 LIGHTNING CONDUITS

1114.1 Lightning conductors shall be securely fastened and conform to local by-laws.

SECTION 12 DIESEL GENERATORS:

INDEX

12.01 Nature of work..... 167

12.02 General description.....167

12.03 Base Frame... .. 167

12.04 Diesel Engine.....167

12.05 Fuel tank... .. 167

12.06 Fuel..... 168

12.07 Hand pump... .. 168

12.08 Exhaust pipes... .. 168

12.09 Starting... .. 168

12.10 Electrical... .. 168

12 DIESEL GENERATOR

12.01 Nature of work

The diesel generating plant shall be required for supply of electrical power for lighting and various other appliances including motors to submersible borehole pumps.

Each of the diesel generating sets offered shall comply with the specifications and requirements given below. Switchboards shall be offered for each generating sets as specified.

12.02 General Description

The offered generating sets shall in compliance with BS 649 and 2613 or any other standard approved by the Contract Administrator.

12.03 Base frame

The Base-frame shall be all welded steel for mounting of engine and generator with vibro insulators mounted directly to the frame and for resenting on floor without any attachment to foundation. Each vibro damper shall be adjusted to allow the weight to be evenly distributed during installation, mounting tray for starting battery and necessary sub-frames for assembly.

12.04 Diesel Engine

These shall be at four stroke type running at speed of 1,500 r.p.m. naturally aspirated, radiator cooled, or air cooled, complete supplied and mounted with:

- fuel filter,
- dry air cleaner, or oil bath
- oil cooler, where necessary
- oil pressure gauge
- oil filter,
- Speed governor, to BSS. 6459:1958 Class A2

-
- water temperature gauges,
 - hour counter, mounted in ant vibration place (switchboard)
 - Oil pressure switch for automatic shut-down of entire in the event of oil supply failure, or low pressure failure.
 - Cooling water temperature switch for automatic shut-down of engine in the event of excessive temperature, or equal for air cooled unit.
 - radiator, protected from mechanical damage, mounted to withstand engine vibrations,
 - Flexible fuel pipes complete with couplings, each pipe with a length suitable for connecting fuel tank.
 - exhaust manifold with flange for connection of flexible exhaust pipe,
 - necessary vibration dampers
 - exhaust

12.05 Fuel tank

The daily service fuel tank should be installed indoors. The capacity of the tank should cover 24 hours generator running.

12.06 Fuel will be fed by gravity to the generator or by engine driven fuel lift pump.

12.07 Hand pump shall be provided in order to pump the fuel out of drums into the fuel tank. The fuel for one 24h tank will be provided free of charge by the contractor.

12.08 Exhaust pipes

The exhaust piping end should be to standard and projecting approx. 1m above roof level. The roof pipe assembly is to be included in the supply as well as a silencer.

12.09 Starting

The generator should be started by hand and/or electric manual starting equipment. It shall also be installed with the start automatic mains failure set.

12.10 Electrical

All electrical installation with cables, wiring fuses, switches etc. and connections to the existing distribution system will be provided by the contractor.

SECTION VI: SPECIAL SPECIFICATIONS

TECHNICAL SPECIFICATIONS FOR SUBMERSIBLE SLUDGE PUMPS

1. Submersible pumps shall be of the single entry design supplied complete with boltless self-aligning duck-foot assemblies giving automatic connection to the discharging pipe work. The pump casing shall be manufactured from close grained grey iron to BS 1452.
2. An oil filled casing shall separate the electric motor from the centrifugal pump. Mechanical seals shall be fitted to the pump shaft, which shall prevent water from entering the oil casing and oil from entering the motor casing. A moisture detection system shall be provided to initiate an external alarm.
3. The motor housing shall be impregnated to protect the ingress of moisture. The shaft bearing shall be sealed and lubricated for life
4. Each pump shall be provided with its own galvanized steel guide rails, fittings and all the necessary support brackets. A suitable lifting chain shall be attached to each pump to enable the pumps to be raised and removed from the wet well without the necessity for personnel entering the well. The lifting chain shall comply with BS 3113 and BS 4942
5. The submerged cable shall be a multi-core flexible cord, vulcanised rubber insulated with tough rubber sheath and outer PCP sheath to BS 6500

6. Where both thermal protective and moisture -sensitive devices are incorporated within the pump, both devices shall be brought out via separate conductors within the motor cable, although one such conductor may be common.

SECTION VII: TENDER FORMS

A. Form of Tender

Bidders Letter head

[date]

To:

**HEAD OF PROCUREMENT
 ISIOLO COUNTY
 P.O. BOX 36-600300
 ISIOLO**

We offer to execute the [name and identification number of contract] in accordance with the Conditions of Contract accompanying this Tender for the Contract Price of [amount in numbers], [amount in words] [name of currency].

The Contract shall be paid in the following currencies:

Currency	Percentage payable in currency	Rate of exchange: one foreign equals [insert local]	Inputs for which foreign currency is required
(a)			
(b)			

The advance payment required is:-

Amount	Currency
(a)	
(b)	

We accept the appointment of The Institution of Engineer's of Kenya as the adjudicator.

or

We do not accept the appointment The Institution of Engineer's of Kenya as the Adjudicator, and propose instead that [name] be appointed as Adjudicator, whose daily fees and biographical data are attached.

We are not participating, as Tenders, in more than one Tender in this Tendering process other than alternative Tenders in accordance with the Tendering documents.

Our firm, its affiliates or subsidiaries, including any subcontractors or suppliers for any part of the contract has not been declared ineligible by the Kenya Government under Kenya's laws or any other official regulations.

This Tender and your written acceptance of it shall constitute a binding Contract between us.

We understand that you are not bound to accept the lowest or any Tender you receive.

We hereby confirm that this Tender complies with the Tender validity and Tender Security required by the Tendering documents and specified in the Tender Data Sheet.

Authorized Signature: _____

Name and Title of Signatory: _____

Name of Tenderer: _____

Address: _____

Appendix to Tender

Schedule of Adjustment Data

[In Tables A, B, and C, below, the Tenderer shall (a) indicate its amount of local currency payment, (b) indicate its proposed source and base values of indices for the different foreign currency elements of cost, (c) derive its proposed weightings for local and foreign currency payment, and (d) list the exchange rates used in the currency conversion. In the case of very large and/or complex works contracts, it may be necessary to specify several families of price adjustment formulae corresponding to the different works involved.]

Table A. Local Currency

Index code	Index description	Source of index	Base value and date	Tenderer's related currency amount	Range of weighting Proposed by the Procuring Entity	Tenderer's proposed weighting
	Nonadjustable	—	—	—	a: _____* b: ----- to ----- -* c: ----- to ----- -* d: ----- to ----- -* e: ----- to ----- -* etc.	a: _____* b: _____ c: _____ d: _____ e: _____ etc.
Total						1.00

Table B. Foreign Currency

State type: [If the Tenderer wishes to quote in more than one foreign currency, this table should be repeated for each foreign currency.]

Index code	Index description	Source of index	Base value and date	Tenderer's related source currency in type/ Amount	Equivalent in Foreign Currency 1	Range of weighting Proposed by the Procuring Entity	Tenderer's proposed weighting
	Nonadjustable	—	—	—		a: _____* b:----- to - -----* c:----- to - -----* d:----- to -----* e:----- to - -----* etc.	a: _____ b: _____ c: _____ d: _____ e: _____ etc.
Total							1.00

Table C. Summary of Payment Currencies

For [insert name of Section of the Works]

[Separate tables may be required if the various sections of the Works (or of the Bill of Quantities) will have substantially different foreign and local currency requirements. The Procuring Entity should insert the names of each Section of the Works.]

Name of payment currency	A Amount of currency	B Rate of exchange (local currency per unit of foreign)	C Local currency equivalent C = A x B	D Percentage of Net Tender Price (NBP) $\frac{100 \times C}{NBP}$
Local currency		1.00		
Foreign currency #1				
Foreign currency #2				
Foreign currency #				
Net Tender Price				100.00
Provisional sums expressed in local currency	*	*	*	
TENDER PRICE				

Authorized Signature: _____

Name and Title of Signatory: _____

Name of Tenderer: _____

Address: _____

Tender-Securing Declaration (Must be filled in bidders letter head)

Date: *[insert date (as day, month and year)]*

Tender No.: *[insert number of Tendering process]*

Alternative No.: *[insert identification No if this is a Tender for an alternative]*

To:

Northern Water Works Development Agency

We, the undersigned, declare that:

We understand that, according to your conditions, Tenders must be supported by a Tender-Securing Declaration.

We accept that we will automatically be suspended from being eligible for Tendering in any contract with the Procuring Entity for the period of time of *[insert number of months or years]* starting on *[insert date]*, if we are in breach of our obligation(s) under the Tender conditions, because we;

Have withdrawn our Tender during the period of Tender validity specified in the Form of Tender; or

- a) Having been notified of the acceptance of our Tender by the Procuring Entity during the period of Tender validity,
 - (i). Fail or refuse to execute the Contract, if required, or
 - (ii). Fail or refuse to furnish the Performance Security, in accordance with the ITT.

We understand this Tender Securing Declaration shall expire if we are not the successful Tenderer, upon the earlier of;

- 1) Our receipt of your notification to us of the name of the successful Tenderer; or
- 2) Thirty days after the expiration of our Tender.

Signed: *[insert signature of person whose name and capacity are shown]* In the capacity of *[insert legal capacity of person signing the Tender Securing Declaration]*

Name: *[insert complete name of person signing the Tender Securing Declaration]*

Duly authorized to sign the Tender for and on behalf of: *[insert complete name of Tenderer]*

Dated on _____ day of _____, _____ *[insert date of signing]*

B. Confidential Business Questionnaire

- 1 **Individual Tenderer or Individual Members of joint Ventures**
- 1.1 Constitution or legal status of Tenderer: *[attach copy]*
- Place of registration: *[insert]*
- Principal place of business: *[insert]*
- Power of attorney of signatory of Tender: *[attach]*
- Registration certificate *[attach]* current Business License *[attach]*
- 1.2 Total annual volume of construction work performed in two years, in Kenyan shillings as specified in the Tender Data Sheet; *[insert]*
- 1.3 Work performed as prime Contractor on works of a similar nature and volume over the last two years or as specified in the Tender Data Sheet in Kenyan Shillings. Also list details of work under way or committed, including expected completion dates.

Project name and country	Name of client and contact person	Contractors Participation	Type of work performed and year of completion	Value of contract
(a)				
(b)				

- 1.4 Major items of Contractor's Equipment proposed for carrying out the works. List all information requested below. Refer also to sub-Clause 12.3 of the Instructions to Tenderers.

Item of equipment	Description, make, and age (years)	Condition (new, good, Poor) and number available	Owned, leased (from whom?) or to be purchased (from whom?)
(a)			
(b)			
(c)			
(d)			

- 1.5 Qualifications and experience of key personnel proposed

for administration and execution of the Contract. Attach biographical data. Refer also to sub-Clause 12.3 of the Instructions to Tenderers and Sub- Clause 10.1 of the General Conditions of Contract.

Position	Name	Years of Experience (general)	Years of experience in proposed position
(a)			
(b)			

1.6 Proposed sub-contractor and firms involved. Refer to Clause 7 of General Conditions of Contract.

Sections of the Works	Value of subcontract	Subcontractor (name and address)	Experience in similar work
(a)			
(b)			

1.7 Financial reports for the number of years specified in the Tender Data Sheet.

1.8 Evidence of access to financial resources to meet the qualification requirements: cash in hand, lines of credit, etc. List below and attach copies of support documents.

1.9 Name, address, and telephone, e-mail address, and facsimile numbers of banks that may provide references if contracted by the Procuring Entity.

1.10 Information on current litigation in which the Tenderer is involved.

Other party(ies)	Cause of dispute	Amount involved
(a)		
(b)		

1.11 Statement of compliance with the requirements of sub-

Clause 3.2 of the Instructions to Tenderers.

- 1.12 Proposed Program (work method and schedule). Descriptions, drawings, and charts, as necessary, to comply with the requirements of the Tendering documents.
2. **Joint Ventures**
- 2.1 The information listed in 1.1 – 1.11 above shall be provided for each partner of the joint venture.
- 2.2 The information in 1.12 above shall be provided for the joint venture.
- 2.3 Attach the power of attorney of the signatory (ies) of the Tender authorizing signature of the Tender on behalf of the joint venture.
- 2.4 Attach the Agreement among all partners of the joint venture (and which is legally binding on all partners), which shows that:
- (a) all partners shall be jointly and severally liable for the execution of the Contract in accordance with the Contract terms;
 - (b) one of the partners will be nominated as being in charge, authorized to incur liabilities, and receive instructions for and on behalf of any and all partners of the joint venture; and
 - (c) the execution of the entire Contract, including payment, shall be done exclusively with the partner in charge.
3. **Additional Requirements**
- 3.1 Tenderers should provide any additional information required in the **Tender Data Sheet** or to fulfil the requirements of sub-Clauses 12.1 of the Instructions to Tenderers, if applicable.

C. Integrity Declaration

UNDERTAKING BY TENDERER ON ANTI – BRIBERY POLICY / CODE OF CONDUCT AND COMPLIANCE PROGRAMME

1. Each Tenderer must submit a statement, as part of the Tender documents, in either of the two given formats which must be signed personally by the Chief Executive Officer or other appropriate senior corporate officer of the Tendering company and, where relevant, of its subsidiary in the Kenya. If a Tender is submitted by a subsidiary, a statement to this effect will also be required of the parent company, signed by its Chief Executive Officer or other appropriate senior corporate officer.
2. Tenderers will also be required to submit similar No-bribery commitments from their subcontractors and consortium partners; the Tenderer may cover the subcontractors and consortium partners in its own statement, provided the Tenderer assumes full responsibility.
3.
 - a) Payment to agents and other third parties shall be limited to appropriate compensation for legitimate services.
 - b) Each Tenderer will make full disclosure in the Tender documentation of the beneficiaries and amounts of all payments made, or intended to be made, to agents or other third parties (including political parties or electoral candidates) relating to the Tender and, if successful, the implementation of the contract.
 - c) The successful Tenderer will also make full disclosure [quarterly or semi-annually] of all payments to agents and other third parties during the execution of the contract.
 - d) Within six months of the completion of the performance of the contract, the successful Tenderer will formally certify that no bribes or other illicit commissions have been paid. The final accounting shall include brief details of the goods and services provided that they are sufficient to establish the legitimacy of the payments made.
 - e) Statements required according to subparagraphs (b) and (d) of this paragraph will have to be certified by the company's Chief Executive Officer, or other appropriate senior corporate officer.
4. Tenders which do not conform to these requirements shall not be considered.

-
5. If the successful Tenderer fails to comply with its No-bribery commitment, significant sanctions will apply. The sanctions may include all or any of the following:
 - a) Cancellation of the contract;
 - b) Liability for damages to the public authority and/or the unsuccessful delays in the Tendering possibly in the form of a lump sum representing a pre-set percentage of the contract value (liquidated).
 6. Tenderers shall make available, as part of their Tender, copies of their anti-Bribery Policy/Code of Conduct, if any, and of their-general or project - specific - Compliance Program.
 7. The Government of Kenya has made special arrangements for adequate oversight of the procurement process and the execution of the contract, and has invited civil society and other competent Government Departments to participate in the oversight. Those charged with the oversight responsibility will have full access to all documentation submitted by Tenderers for this contract, and to which in turn all Tenderers and other parties involved or affected by the project shall have full access (provided, however, that no proprietary information concerning a Tenderer may be disclosed to another Tenderer or to the public).

ANTI-CORRUPTION DECLARATION COMMITMENT/ PLEDGE

(Sections 39, 40, 41, 42, 43 & of the PPD Act, 2005)

I/We/Messrs.....

of Street, Building, P O Box.....

.....

Contact/Phone/E mail.....

declare that Public Procurement is based on a free and fair competitive Tendering process which should not be open to abuse.

I/We

declare that I/We will not offer or facilitate, directly or indirectly, any inducement or reward to any public officer, their relations or business associates, in connection with

Tender/Tender No

for or in the subsequent performance of the contract if I/We am/are successful.

Authorized Signature.....

Name and Title of Signatory.....

D. Letter of Acceptance

[Letter head paper of the Procuring Entity]

[date]

To: *[name and address of the Contractor]*

This is to notify you that your Tender dated [date] for execution of the [name of the Contract and identification number, as given in the Contract Data Sheet] for the Contract Price of the equivalent of [amount in numbers and works] [name of currency], as corrected and modified in accordance with the Instructions to Tenderers is hereby accepted by us.

We confirm that [insert name proposed by the procuring entity] to be the Adjudicator.

We accept that [name proposed by Tenderer] be appointed as Adjudicator.

Or

We do not accept that [name proposed by Tenderer] be appointed as adjudicator, and by sending a copy of this letter of acceptance to [insert the name of the Appointing Authority], we are hereby requesting [name], the Appointing Authority, to appoint the adjudicator in accordance with Clause 44.1 of the Instructions to Tenderers.

You are hereby instructed to proceed with the execution of the said works in accordance with the Contract documents.

Please return the contract dully signed.

Authorized Signature: _____

Name and Title of Signatory: _____

Name of Agency: _____

Attachment: Form of Contract

E. Form of Contract Agreement

This Agreement, made the [day] day of [month], [year] between [name and address of Procuring Entity] (hereinafter called “the Procuring Entity”) and [name and address of Contractor] (hereinafter called “the Contractor”) of the other part.

Whereas the Procuring Entity is desirous that the Contractor execute [name and identification number of contract] (hereinafter called “the Works”) with the objectives of [insert functional objectives of the works] and the Procuring Entity has accepted the Tender by the Contractor for the execution and completion of such works and the remedying of any defects therein in the sum of [contract price in words and figures] (hereinafter called “Contract Price”).

NOW THIS AGREEMENT WITNESSES AS FOLLOWS:

1. In this Agreement, words and expressions shall have the same meanings as are respectively assigned to them in the Conditions of Contract hereinafter referred to, and they shall be deemed to form and be read and construed as part of this Agreement;
2. In consideration of the payments to be made by the Procuring Entity to the Contractor as hereinafter mentioned, the Contractor hereby covenants with the Procuring Entity to execute and complete the Works and remedy any defects therein in conformity in all respects with the provisions of the Contract;
3. The Procuring Entity hereby covenants to pay the Contractor in consideration of the execution and completion of the Works and the remedying of defects wherein the Contract Price or such other sum as may become payable under the provisions of the Contract at the times and in the manner prescribed by the Contract.

In Witness whereof the parties thereto have caused this Agreement to be executed the day and year first before written.

The Common Seal of _____

Was hereunto affixed in the presence of: _____

Signed, Sealed, and Delivered by the said _____

In the presence of: _____

Tendering Signature of Procuring Entity _____

Binding Signature of Contractor _____

SECTION VIII: FORMS OF SECURITY

F. Tender Security (Bank/ Insurance Guarantee)

*[If required, the **Bank Tenderer** shall fill in this Guarantee form in accordance with the instructions indicated in brackets.]*

[insert bank's or insurance company's name, and address of issuing branch or office]

Beneficiary: *[insert name and address of Procuring Entity]*

Date: *[insert date]*

TENDER GUARANTEE No.: *[insert number]*

We have been informed that *[insert name of the Tenderer; if a joint venture, list complete legal names of partners]* (hereinafter called "the Tenderer") has submitted to you its Tender dated *[insert date]* (hereinafter called "the Tender") for the execution of *[insert name of Contract]* under Invitation for Tenders No. *[insert IFT number]* ("the IFT").

Furthermore, we understand that, according to your conditions, Tenders must be supported by a Tender Guarantee.

At the request of the Tenderer, we *[insert name of bank or insurance company]* hereby irrevocably undertake to pay you any sum or sums not exceeding in total an amount of *[insert amount in figures expressed in the currency of the Purchaser's Country or the equivalent amount in an international freely convertible currency] ([insert amount in words])* upon receipt by us of your first demand in writing accompanied by a written statement stating that the Tenderer is in breach of its obligation(s) under the Tender conditions, because the Tenderer;

- a) Has withdrawn its Tender during the period of Tender validity specified by the Tenderer in the Form of Tender; or
- b) Does not accept the correction of errors in accordance with the Instructions to Tenderers (hereinafter "the ITT") of the IFT; or
- c) Having been notified of the acceptance of its Tender by the Procuring Entity during the period of Tender validity;
 - (i). Fails or refuses to execute the Contract Form, if required, or
 - (ii). Fails or refuses to furnish the Performance Security, in accordance with the ITT.

This Guarantee shall expire;

- a) If the Tenderer is the successful Tenderer, upon our receipt of copies of the Contract signed by the Tenderer and of the Performance Security issued to you by the Tenderer; or
- b) If the Tenderer is not the successful Tenderer, upon the earlier of;

-
- (i) Our receipt of a copy of your notification to the Tenderer that the Tenderer was unsuccessful, or
 - (ii) Thirty days after the expiration of the Tenderer's Tender.

Consequently, any demand for payment under this Guarantee must be received by us at the office on or before that date.

[signature(s) of authorized representative(s)]

G. Performance Bond

[The **successful Tenderer** providing the Guarantee shall fill in this form in accordance with the instructions indicated in brackets, if the Procuring Entity requires this type of security.]

[insert bank's or insurance company's name, and address of issuing branch or office]

Beneficiary: *[insert name and address of Procuring Entity]*

Date: *[insert date]*

PERFORMANCE GUARANTEE No.: *[insert Performance Guarantee number]*

We have been informed that *[insert name of Contractor]* (hereinafter called "the Contractor") has entered into Contract No. *[insert reference number of the Contract]* dated with you, for the execution of *[insert name of Contract and brief description of Works]* (hereinafter called "the Contract").

Furthermore, we understand that, according to the conditions of the Contract, a Performance Guarantee is required.

At the request of the Contractor, we *[insert name of Bank or Insurance Company]* hereby irrevocably undertake to pay you any sum or sums not exceeding in total an amount of *[insert amount in figures]* (*[insert amount in words]*), such sum being payable in the types and proportions of currencies in which the Contract Price is payable, upon receipt by us of your first demand in writing accompanied by a written statement stating that the Contractor is in breach of its obligation(s) under the Contract, without your needing to prove or to show grounds for your demand or the sum specified therein.

We hereby waive the necessity of your demanding the said debt from the Contractor before presenting us with the demand.

We further agree that no change, addition or other modification of the terms of the Contract or of the Works to be performed there under or of any of the Contract documents which may be made between you and the Contractor shall in any way release us from any liability under this Guarantee, and we hereby waive notice of any change, addition, or modification.

This guarantee shall expire not later than thirty days from the date of issuance of the Taking-Over Certificate.

[signature(s) of an authorized representative(s) of the Bank]

SECTION IX: BILL OF QUANTITIES

PREAMBLES TO THE BILL OF QUANTITIES

1.0 General

- 1.1 The Bill of Quantities shall be read in conjunction with the Conditions of Contract, conditions of particular applications, Specifications and special provisions, Drawings and Employer's requirements and the Contractor shall provide against the bill rates or in the prices for the full scope of the work covered by the Contract, no claim or variations shall be considered on account of the Tender's failure to comply with this provision. The various documents collectively referred to herein as the Bill of Quantities shall jointly constitute the Bill of Quantities referred to in the Conditions of Contract and these preambles are to be read in conjunction with item descriptions in the Bill of Quantities.
- 1.2 Lump Sum values shall not be inserted where unit rates are applicable and the contractor shall ensure that identical items occurring in separate bills are not priced at different rates, unless this is the deliberate intention.
- 1.3 The contractor shall check against the summaries that each copy of the Bill of Quantities is complete in the number of pages and in the reproduction of each page.
- 1.4 Unit rates, prices and extensions shall be given in the Kshs with Cents taken to two decimal places.
- 1.5 The Bill of Quantities has generally been measured in accordance with ***Civil Engineering Standard Method of Measurement Fourth Edition (CESMM4), as published by Institution of Civil Engineers (ICE) publishing, 40 Marsh Wall, London E14 9TP***
- 1.6 The Quantities inserted against items in the Bill of Quantities are estimated quantities of the Works for the purpose of Tender Evaluations, and the Contractor shall be deemed to have checked and verified such quantities in the compilation of his Tender Price prior to the submission of his Tender. Upon the award of the Contract, the priced Bill of Quantities shall be used solely for evaluating interim payments due to the Contractor, and as a schedule of rates for establishing the value of variations.

1.7 The Contractor shall not use the Bill of Quantities for the purpose of ordering materials or arranging Subcontractors. References to these activities shall be the Specifications and Drawings and instructions issued by the Engineer.

1.8 All items in the Bill of Quantities shall be deemed to have a monetary value, whether priced or un-priced. In the absence of a unit rate or price against any item, the cost shall be deemed to have been included elsewhere within the Contract Price and the work described to that item shall be executed by the Contractor without any additional payment.

1.9 The descriptions in the Bill of Quantities may be incomplete and the Contractor is referred to the Drawings, and Specifications for complete information in respect of all the relevant descriptions, quality, dimensions, capacities, design parameters and the like.

2.0 Format of Descriptions

2.1 In addition to common abbreviations the following have been adopted;

Unit	Abbreviation
Millimeter	mm
Meter	m
Square millimeter	mm ² or mm2
Square meter	m ² or m2
Cubic meter	m ³ or m3
Hectare	ha
Kilogramme	kg
Tonne	t
Sum	sum
Number	nr
Hour	h
Week	wk

3.0 Rates

3.1 Rates and Prices shall be all inclusive, comprehensive and include the following:

- a) All obligations imposed by the Contract.
- b) Complying in every respect with the requirements and the considerations of the Specifications and Drawings.

-
- c) All considerations arising from the definitions incorporated in each Preamble section.
 - d) Laborer for fixing and all associated costs.
 - e) Materials and goods and all associated costs
 - f) Fitting and /or fixing materials and goods in any position, hoisting to any height.
 - g) Use of Scaffolding, plant, equipment and tools.
 - h) Any additional laborers usually associated with measured items.
 - i) All necessary protection of the Works, removing all temporary installations and making good and clearing away upon completion.
 - j) All applicable taxes, duties, charges, government levies, landing charges and transport.
 - k) Overheads & profit.

4.0 Measurements

- 4.1 All measurements are net and the rates shall include for all laps, waste, working space and trade or traditional allowances.
- 4.2 The pricing of materials shall take account of the following:
 - A) Pricing Preambles, Drawings and specifications shall apply reciprocally between the various sections of the Works, unless otherwise described.
 - B) Materials shall be of the specified quality unless otherwise described.
 - C) All materials shall be transported, handled, stored and fixed in accordance with the printed instruction or recommendations of their manufacturer or suppliers.
 - D) Protection of completed work, all casings and temporary coverings and making good and clearing away upon completion.

5.0 Discrepancies

- 5.1 Any discrepancy arising in terms of these Preambles and the items contained within the Bill of Quantities must be brought to the attention of the Contract Administrator for his clarification prior to the submission of tender.

BILL OF QUANTITIES

BILL OF QUANTITY FOR REHABILITATION AND AUGUMENTATION OF MODOGASHE WATER SUPPLY					
1.00	Bill No.1: -Preliminaries and General Items				
Item No.	Description	Unit	Qty	Rate (Kshs)	Amount (Kshs)
1.01	Mobilization and demobilization of drilling machinery, personnel and equipment. Include for camp setting. Include for Project sign Board installation	Item			
1.02	Provide and fix Project sign Board include for brading of Tank, kiosks and Generator house as directed by the project Engineer.				
1.03	Compliance with environmental and social safeguard and Provision and Supply of PPEs for workers to meet EMMP.(Reflectors, Helmets, safety boots). Include for county supervising team)	LS			100,000.00
1.04	Provide for acquisition of Authorization and drilling permits from Water Resources Authority (WRA). Including acquisition of No consent letter from respective Water Resources Users Association (WRUA)	PS			80,000.00
1.05	Allow provisional sum of Kshs. 200,000 for Environmental and Social Impact Assessment for the project in compliance to Statutory obligations. Include for project management committee engagement	Ls			200,000.00
1.06	Allow a provisional sum of Kenya shillings Five hundred thousand (Kshs 500,000) to be utilized in Project Community Management Training as directed the Project Manager	Ls			500,000.00
1.07	Allow for project management and supervision	Ls	1		450,000.00
1.08	Allow for contract profits in item (1.06&1.07)	%	20%	950,000.00	190,000.00
1.09	Allow for provision of water for drilling, construction and camp use	LS			
1.10	Allow for project setting out				100,000.00
TOTAL BILL 1:- carried to summary					
BILL NO.2:-REHABILITATION OF INFILTRATION GALLERY WELL AND EQUIPPING					
Item No.	Description	Unit	Qty	Rate (Kshs)	Amount (Kshs)
2.1	Infiltration Gallery Rehabilitation				
2.1.01	Clear site of all bushes and debris. Grab up roots and burn the arisings	M ²	450		
2.1.02	Excavate/Disilt of existing shallow to depth of 1200mm 9m. Cost to include unclogging /disilting of collector pipes	M ³	22		

2.1.03	Load, wheel and cart deposit and spread surplus excavated material where directed on site at a distance not exceeding 100m.	M ³	22		
2.1.04	Provide and install culverts 1m, 1.2mm dia.	No	4		
2.1.05	Allow for Dewatering, flushing and unclogging of drain/ collector pipes	LS			
2.1.06	Allow for 24hrs test pumping for the two wells	Ls	2		
2.1.07	RCC well covers circular in plan specs:- 1.5m dia. 200mm. D12 bars @150mm c/c herically.	No	2		
2.1.08	Allow for rehabilitation of existing protection wall and construction of Lockable well chamber 3.5mx3.5m x 1m	No	2		
	TOTAL I:- Carried to summary				
2.2	Shallow Well Equipping				
2.2.01	Provide and fix a submersible pump complete coupled with Motor capable of delivering minimum 3m ³ /hr against a head 50m. c	No.	1		
2.2.02	4 core submersible cable 10mm ²	M.	120		
2.2.03	1.0mm ² dual londex cable	M.	120		
2.2.04	UPVC 2" standard borehole pipes	No.	3		
2.2.05	Provide for installation of an existing 3Phase Generating set . Include for any necessary wiring and fittings	LS	1		
2.2.06	1.5mm ² underground sensor cable	M.	210		
2.2.07	Armored/underground cable 4 core 6mm ²	M.	210		
2.2.08	Earth rod 1.2m	No.	1		
2.2.09	TP N Fuse-20A	No.	1		
2.2.10	Adaptor set 2"	No.	1		
2.2.11	Convection controller-2.2KW 3Phase	No.	1		
2.2.12	Splicing kit	No.	1		
2.2.13	Allow for KPLC Re-connection	LS	1		
	Total installation for one well				
	For Two Infiltration Wells		2		
	Cost Gallery Rehab and Equipping				
Item No.	Description				
3.1	For Two Infiltration Wells				

3.2	Infiltration Wells Equipping				
	Total gallery Rehab & Equipping: Carried to summary				
	Bill No.2:-Rehabilitation of Infiltration Gallery Well and Equipping				
Item No.	Description	Unit	Qty		
2.1	Infiltration Gallery Rehabilitation				
2.1.01	Clear site of all bushes and debris. Grab up roots and burn the arisings	M ²	450		
2.1.02	Excavate/Disilt of existing shallow to depth of 1200mm 9m. Cost to include unclogging /disilting of collector pipes	M ³	22		
2.1.03	Load, wheel and cart deposit and spread surplus excavated material where directed on site at a distance not exceeding 100m.	M ³	22		
2.1.04	Provide and install culverts 1m, 1.2mm dia.	No	4		
2.1.05	Allow for Dewatering, flushing and unclogging of drain/ collector pipes	LS			
2.1.06	Allow for 24hrs test pumping for the two wells	Ls	2		
2.1.07	RCC well covers circular in plan specs:- 1.5m dia. 200mm. D12 bars @150mm c/c herically.	No	2		
2.1.08	Allow for rehabilitation of existing protection wall and construction of Lockable well chamber 3.5mx3.5m x 1m	No	2		
	TOTAL I:- Carried to summary				
2.2	Shallow Well Equipping				
2.2.01	Provide and fix a submersible pump complete coupled with Motor capable of delivering minimum 3m ³ /hr against a head 50m. c	No.	1		
2.2.02	4 core submersible cable 10mm ²	M.	120		
2.2.03	1.0mm ² dual londex cable	M.	120		
2.2.04	UPVC 2" standard borehole pipes	No.	3		
2.2.05	Provide for installation of an existing 3Phase Generating set . Include for any necessary wiring and fittings	LS	1		
2.2.06	1.5mm ² underground sensor cable	M.	210		
2.2.07	Armored/underground cable 4 core 6mm ²	M.	210		
2.2.08	Earth rod 1.2m	No.	1		
2.2.09	TP N Fuse-20A	No.	1		
2.2.10	Adaptor set 2"	No.	1		

2.2.11	Convection controller-2.2KW 3Phase	No.	1		
2.2.12	Splicing kit	No.	1		
2.2.13	Allow for KPLC Re-connection	LS	1		
	Total installation for one well				
	For Two Infiltration Wells		2		
	Cost Gallery Rehab and Equipping				
Item No.	Description				Amount (Kshs)
3.1	For Two Infiltration Wells				
3.2	Infiltration Wells Equipping				
	Total gallery Rehab & Equipping: Carried to summary				
	BILL NO 3: -BOREHOLE DRILLING				
Item No.	Description	Unit	Qty	Rate (Kshs)	Amount (Kshs)
3.1	Borehole drilling (Mud drilling)				
	<i>Include for provision of foam, polymer solution and bentonite powder to achieve required bore depth and diameter as required</i>				
	Drilling depth from 0 but not exceeding 100.0 metres for the conductor pipe -350mm internal Diameter.	M	50		
3.1.01	Drilling depth from 0 but not exceeding 100.0 metres for the conductor pipe -300mm internal Diameter.	M	50		
3.1.02	Drilling depth from 100 but not exceeding 200.0 metres for the conductor pipe -300mm internal Diameter.	M	60		
3.1.03	Sampling and logging works at 2.0m intervals	No.	80		
	INSTALLATION OF CASINGS and SCREENS AND GRAVEL PACKING				
3.1.04	Provide for installation of 12 inches (300mm) diameter surface plain casing to stabilize hole on top formation	M	20		
3.1.05	Provide for installation of 12 inches (300mm) diameter surface perforated /screened casing to stabilize hole on top formation	M	20		
3.1.06	Provide install and weld - 250mm internal diameter steel casings, 4mm thickness class B - Plain	M	100		
3.1.07	Ditto 250mm internal diameter steel screens, 4mm thickness class B - plasma slotted.	M	60		
3.1.08	250mm internal diameter slide - in borehole cap	No.	1		

3.1.09	Supply and gravel pack the borehole:- Gravel Specs- quartz pea gravel, 2-4mm grain size	Ton	12		
3.1.10	Provide 1.2mx1.2mx2m deep concrete borehole plinth (finished slab) (1:2:4) and sealing off/protecting the hole from surface pollution	m3	3		
	BOREHOLE DEVELOPMENT				
3.1.11	Physical development through air-jetting techniques	HR	12		
3.1.13	Chemical development through Calgon injection.	KG	40		
	AQUIFER TESTING (TEST PUMPING & WATER QUALITY ANALYSIS)				
3.1.14	Mobilization and demobilization of test pumping unit	Item	1		
3.1.15	Installation of test pumping unit & removal.	Item	1		
3.1.16	Testing (Pumping Test) (Pre-test, step and/or constant drawdown/discharge tests)	HR	24		
3.1.17	Testing (Recovery Test)	HR	6		
3.1.18	Water sample for chemical & physical analysis	LS	1		
3.1.19	Processing of Borehole Completion report, borehole serial number, water quality lab analysis and report.	No.	1		
	SUB-TOTAL =(Carried to summary)				
3.2	Borehole Protection				
3.2.01	Borehole protection: Provide and fix Gabions boxes 1.5m protection surround. The boxes should be packed with hard silt free approved rocks and packed as directed by the Engineer. Cost to include necessary excavation.	M	40		
3.2.02	Construct 1200mm x1200mm x 1000mm Borehole chamber with lockable cover	No.	1		
	Total Cost of Borehole Protection				
	Cost Borehole drilling and Protection				
Item No.	Description				Amount (Kshs)
3.1	Borehole drilling				
3.2	borehole protection				
	Total Borehole Drilling &Protection:- Carried to summary				
	BILL NO.4:- BOREHOLE EQUIPPING				
Item No.	Description	Unit	Qty	Rate (Kshs)	Amount (Kshs)

4.01	Provide and fix a suitable approved submersible pump coupled with 5.5KW Motor capable of delivering minimum 10m ³ /hr against a head 150m.	No.	1		
4.02	4 core submersible cable 10mm ²	M.	120		
4.03	1.0mm ² dual lonlex cable	M.	120		
4.04	UPVC 2" std borehole pipes	No.	33		
4.05	Borehole cover 6"x 2"	No.	1		
4.06	Airline pvc pipe 25mm	No.	33		
4.07	1.5mm ² underground sensor cable	M.	210		
4.08	Armored/underground cable 4 core 10mm ²	M.	210		
4.09	545w solar modules	No.	15		
4.1	Earth rod 4ft	No.	1		
4.11	P.V disconnect 1000vdc 40A	No.	1		
4.12	Adaptor set 2"	No.	1		
4.13	Sunverter 3 7.5kw controller	No.	1		
4.14	3m structure for 15, 545w solar panes	L.S	1		
4.15	Splicing kit	No.	1		
4.16	Lightening arrestor	L.S	1		
4.17	Installation sandries	L.S	1		
	TOTAL				
5.0	BILL NO. 5 :- CONSTRUCTION OF GENERATOR HOUSE (5M BY 7M)				
Item No.	Description	Unit	Qty	Rate (Kshs)	Amount (Kshs)
	GENERATOR HOUSE				
	EXCAVATION				
5.01	Strip topsoil to a mazimum of 250 mm depth	m ³	22		
5.02	Excavate for the slab in depth 0 - 1.5 m	m ³	8		
5.03	Excavate trench for foundation in depths of 0-1.5m	m ²	63		
5.04	Compaction for final surface under slab	m ²	63		
	HARDCORE				
5.05	200 mm thick hardcore below floor slab	m ²	20		
5.06	50 mm thick murrum blinding or similar	m ²	3.5		
5.07	Provide and place 500 gauge polythene sheet damp proof membrane on top of quarry dust	m ²	63		
	CONCRETE				-

5.08	50 mm concrete Grade 15 for blinding	m ²	63		
5.09	Concrete grade 25 to strip footing	m ³	7		
5.10	Ditto to ground floor slab	m ³	11		
5.11	Ditto to 4 No plinth slabs	m ³	3		
5.12	Ditto to ring beams	m ³	4		
5.13	Provide 20 mm screed, cement and sand (1:2) to smooth finish to floor slabs	m ²	65		
	FORMWORK				
5.14	Sawn formwork to sides of the foundation	m ²	100		
5.15	Ditto to sides of walls, and entrance slab	m ²	15		
5.16	Ditto to beams	m ²	35		
	REINFORCEMENT BARS				
	High Tensile to BS4449				
5.17	12 mm diameter	kg	180		
5.18	8 mm diameter	kg	100		
5.19	A 142 mesh	m ²	80		
	BLOCK WORK				
5.20	200 mm concrete block-work walling with cement mortar (1:3)	m	42		
5.21	Bitumen damp proof course 200 mm wide	m	42		
5.22	12 mm cement and sand (1:3) rendering on walls to smooth finish	m ²	230		
5.23	3 coats of plastic emulsion paint	m ²	250		
5.24	Ditto but super gloss on doors, windows etc.	m ²	60		
5.25	200 mm hollow concrete blocks walling with cement mortar (1:3)	m ²	20		
5.26	200 mm concrete block-work walling with cement mortar (1:3)	m ²	20		
	ROOF				
5.27	Provide and fix in position trusses to pump/Generator House	No.	20		
5.28	Ditto purlins	m	120		
5.29	Ditto super seven 3m prepainted Galvanized Sheets	No.	45		
5.30	Ditto pre-painted G.S close fitting ridges	m	20		
5.31	Ditto fascia boards size 175x25mm	m	50		
5.32	Ditto, GS gutter	m	8		
5.33	Ditto, GS gutter stop ends	No.	4		
5.34	Ditto, 100 mm GS DN down-stand pipes for gutter	No.	4		
	FIXTURES				
5.35	Double leaf metal door frame 1.5 m wide by 2.2m high and allow for 300mm long R16 metal grills	No.	2		
	TOTAL GENERATORHOUSE				
6.00	BIILL.NO.6:- PIPEWORK				
ITEM	DESCRIPTION	UNIT	QTY	RATE (Kshs.)	AMOUNT (Kshs.)
6.00	PIPELINE				
	RISING MAIN				

	Trench Excavation:-				
6.01	Provide for pipeline clearing	m2	988		
6.02	In open Ground excavate trench (23400m x 0.6m) depth 1m for pipe laying , refill, ram and dispose	M ³	3,950		
6.03	Extra Over rock excavation	m3	300		
	PIPEWORK				
	Supply, Transport to Site & Store in Secure Place Including Jointing, Bolts, Gaskets, Packing, Jointing Glues, etc., As Applicable. Include for all fittings				
6.03	DN 90mm HDPE PN 12.5	M	1250		
6.04	Ditto 63mm HDPE PN12.5 in distribution mains	M	3200		
6.05	90mm Dia. HDPE adoptor socket	No	29		
6.06	Provide and fix 90mm dia. Approved Master Meter	No	2		
	Carry out pressure testing, cleansing and sterilising of the pipeline in accordance with the specification.				
6.07	Main Pipeline-90mm dia.	m	1,250.00		
6.08	Ditto 63mm main distribution pipeline	M	3200		
6.09	Allow for construction of standard Concrete roofed water kiosk. include for plumbing works , painting and branding as directed by engineer	No	2		
6.10	Construct lockable Valve chambers. Size:- 1200mmX1200mmX1000m	No	4		
	Total Bill 6-Borehole Fencing = carried to summary				
6.11	Fittings (2.5%)	%age	3%		
	Total Bill 6:- Pipework = carried to summary				
7.00	BILL NO. 7:- 100M³ 15M HIGH ELEVATED STEEL TANK				
ITEM NO.	DESCRIPTION	UNIT	QTY	RATE (KShs)	
7.1	<u>CONSTRUCTION OF 5M HIGH 100M³ EST</u>				
	Works comprises of design and fabrication of a 100 Cubic metre tank on a 18 meters tower. The contractor to carryout geophysical survey and design for the tank foundation and provide designs for approval before works commences at the ground. The steel plates, strut and tie members of the frame as well must be assessed at the fabrication site and approved before transportation to site. Material Specification -Cold formed sections to BS 5950 Part 5: 1997 or equivalent. -Bolt and nuts to BS 3692 and BS 4190 or equivalent. -Welding specifications to BS 5135 or equivalent. -Welding electrodes to BS 635 or equivalent. -Wind load to CP3 chapter V part 2				

	Preliminaries				
7.1.01	Provision for geotechnical investigation for the tank foundation and tank design including submission of report and approval for designs.	Ls	I		
	Site Clearance				
7.1.02	Clear area within the Storage Reservoir site of all grass, bushes, shrubs, hedges, grub up roots and cart away to approved tips identified by the Contractor in liaison with Local Authorities, all as directed by the Engineer	m ²	300		
	CLASS E: EARTHWORKS				
	Top Soil Stripping				
7.1.03	Excavate over site for structures, roads, etc. average 150mm deep to remove vegetable soil and stack part of material for use as and where directed by the Engineer, cart away surplus to tips identified by the Contractor in liaison with the Local Authorities	m ²	300		
	EXCAVATION				
7.1.04	Excavate to formation level in common material, part backfill after construction and remainder, cart away to tips identified by the Contractor in liaison with Local Authorities or use as fill on site, all as directed by the Engineer.	m ³	120		
7.1.05	Extra Over excavation items for excavation in rock Class 'A', blasting not permitted (Provisional)	m ³	5.00		
7.1.06	-Ditto- but in rock Class 'B' (Provisional)	m ³	5.00		
7.1.08	-Ditto- but in rock Class 'C' (Provisional)	m ³	5.00		
	CLASS F: IN SITU CONCRETE				
	IN SITU CONCRETE				
	Provide, place, vibrate and cure concrete in the following elements of the structure as per details on drawings				
7.1.09	Designed mix; Class C15; 20mm aggregate plain concrete to blinding under base slab: Thickness 75mm	m ³	2.00		
7.1.10	Designed mix; Class C25; 20mm aggregate Reinforced Concrete to Bases	m ³	20.00		
7.1.11	Designed mix; Class C25; 20mm aggregate Reinforced Concrete to Columns	m ³	6.00		
7.1.12	Designed mix; Class C25; 20mm aggregate Reinforced Concrete to Beams	m ³	6.00		
	CLASS G: CONCRETE ANCILLIARIES				
	Formwork				
	Provide and fix shuttering including propping, strutting and striking, all as specified				
7.1.13	(i) Vertical and Horizontal Formwork - Class F1 Finish				
	Bases, Columns and Beams	m ²	90.00		
	REINFORCEMENT				

	<u>Provide and Fix High Tensile Steel Reinforcement including Ctting, Bending, Propping with Spacers and Tying as specified :-</u>				
7.1.14	10 mm and over	Ton	3.00		
	CLASS M: STRUCTURAL METALWORK				
7.1.15	Design, Fabricate, supply and erect on an elevated steel tower a pressed steel tank effective capacity 100m ³ of 6 mm thick panels elevated at 18m height on tower complete with steel roof cover 3mm sheets, internal bracing, brackets ,access cover and internal and external ladder, calibrated level indicator, fasteners, threaded nozzles, sealants and lockable manhole. Tank to be painted with two coats of non-toxic black bituminous paint internally and one coat of grey primer and two coats of silver aluminum externally. NB.(this is design and build item. the quotation which is lump sum will be accompanied by preliminary design of the tank, technical drawings and design calculations. The tank must be fit for purpose and performance and safety of the tank is the responsibility of the design-build contractor.	nr	1.00		
7.1.16	Design, provide shop drawings, fabricate, deliver and erect a 15m high steel tower above foundation level steelwork complete with primer and aluminum paint to carry 100m ³ steel tank. The tower to comprise of UC/UB angle bracings, chequered plate platform and beams, access cat ladder and railing on the platform and fixtures necessary for erection.	nr	1.00		
	CLASS K: PIPEWORK - MANHOLES AND PIPEWORK ANCILLARIES				
7.1.17	Supply and installation of 90mm dia GI class B Inlet, Outlet, Overflow and Scour pipes, valves and fittings as per the drawings as per the specification to Engineer's approval.	m	60.00		
7.1.18	Construct lockable Valve chambers. Size:- 1200mmX1200mmX1000m	No	2		
7.1.19	Provide for tank Pressure testing	Ls	1		
	TOTAL COST OF EST TANK				
7.2	<u>TANK PERIMETER FENCE AND GATE</u>				
7.2.01	Provide and install 100mm by 125mm by 2.70m long Concrete posts so as to rise 2.1m above the grounds spaced at 3m centre to centre along the perimeter fence(30mx30m)- 120m long	nr	40		
7.2.02	Excavation of holes to anchor posts concere posts	nr	40		
7.2.03	Concrete class 1:3:6 for anchoring the posts	M ³	4		
7.2.04	Provide and install 100mm by 125mm by 2.0m long strainer Concrete posts (double struts) spaced at 30m and at all corners and gate	nr	10		
7.2.05	Excavation of holes to anchor strainer concrete	nr	10		

	posts				
7.2.06	Concrete class 1:3:6 for anchoring the strainer posts	M ³	1		
7.2.07	Supply and fix Berbed wire (barbed wire 12.5g, 25kg)-6 strand along 120m perimeter	M	720		
7.2.08	G12.5 chainlink 2.4m high over 700 m long perimeter	M ²	168		
7.2.09	Supply and install 4000x2000mm double leave steel grill gate to 300x300mm concrete columns complete with iron mongery (use 50mmx25mmx6mm SHS with 38mmx25mmx6mm vertical members). Provide for epoxy primer paint with 2 coats of final gloss paint	nr	1		
7.2.10	Provide, cut and place 10mm square twisted steel rebars in gate columns and 600mmx600mm footing	Kg	40		
7.2.11	Ditto 8mm twisted steel rebars as stirrups in column @150mm	Kg	28		
	Mass concrete class C20/25 in:				
7.2.12	Concrete to poles	M ³	8		
7.2.13	300mmx300mm Gate columns	M ³	1		
	Formwork to;				
7.2.14	Column edges over 150mm but not exceeding 300 mm girth	SM	14		
	Finishes				
7.2.15	25mm thick cement: sand (1:4) screed to surfaces with 12mm thick lime steel trowelled smooth finish on columns	M ²	14		
7.2.16	Gloss painting to columns- code provided by Engineer	M ²	12		
	Provide a concrete chainlink concrete anchorage all round the fence -200mm thick x300mm deep. Include for formwork	M ³	7		
	TOTAL TANK PERIMETER FENCE				
	TANK SUMMARY OF COST				
6.10	TOTAL COST OF EST TANK				
6.20	TOTAL TANK PERIMETER FENCE				
	SUB-TOTAL 6:- CARRIED TO SUMMARY				

SUMMARY OF COSTS		
ITEM NO.	BILL	AMOUNT IN KSHS
1.0	Bill No.1: -Preliminaries and General Items	
2.0	Bill No.2:-Rehabilitation of Infiltration Gallery Well and Equipping	
3.0	Bill No 3: -Borehole Drilling	
4.0	Bill No.4:- Borehole equipping	
5.0	Bill No. 5 :- Construction of Generator House (5m by 7m)	
6.0	BIILL.NO.6:- PIPEWORK	
7.0	BILL NO. 7:- 100M3 15M HIGH ELEVATED STEEL TANK	

	TOTAL	
	ADD 16% V.A.T	
	GRAND TOTAL	

DRAWING

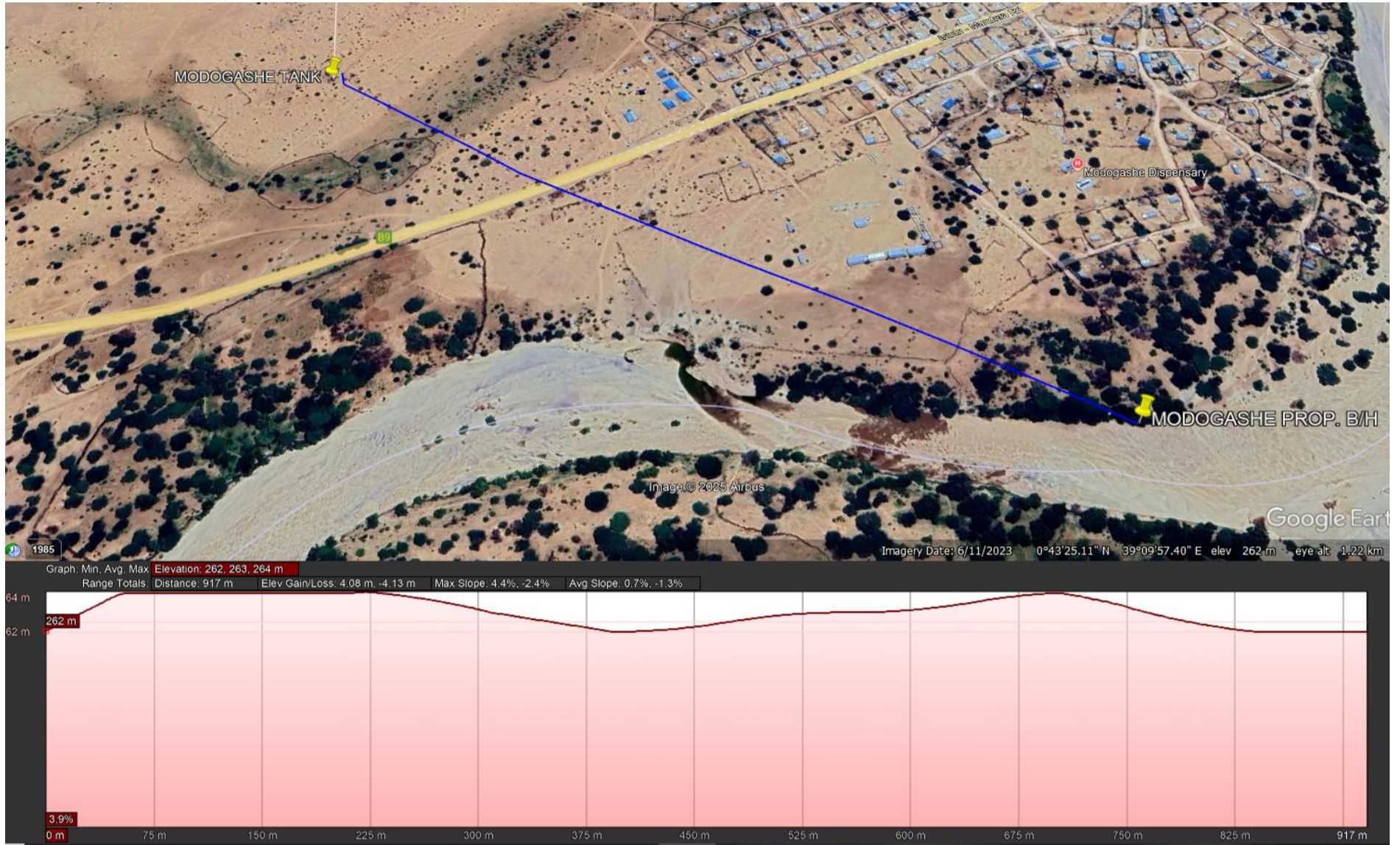

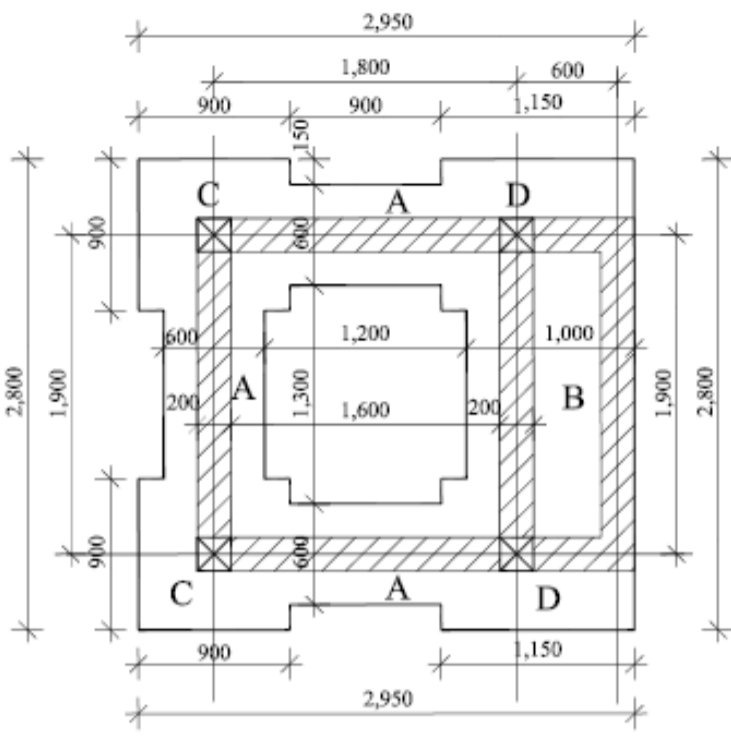

FOUNDATION PLAN

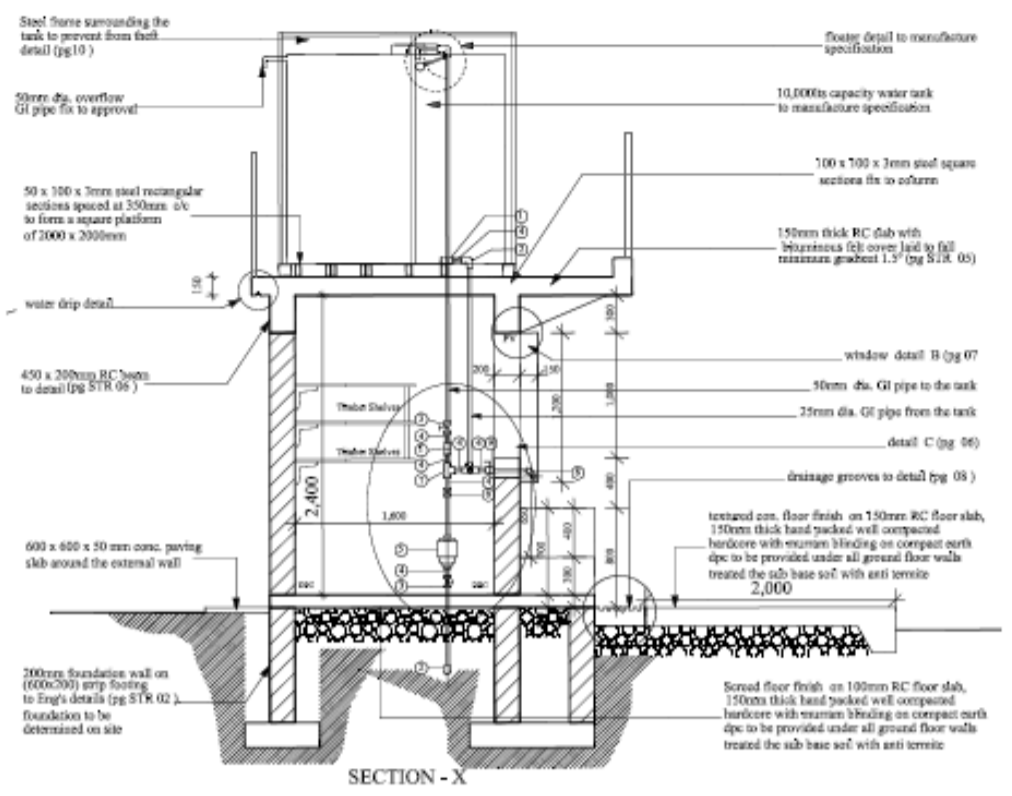

SECTION - X

NOTES

<p>GENERAL</p> <ol style="list-style-type: none"> The drawing is complete. All work shall be done in accordance with the specifications. All dimensions are shown in millimeters unless specified. All work shall be done in accordance with the specifications. All work shall be done in accordance with the specifications. All work shall be done in accordance with the specifications. All work shall be done in accordance with the specifications. All work shall be done in accordance with the specifications. 	<p>STRUCTURAL</p> <ol style="list-style-type: none"> All structural work shall be done in accordance with the specifications. All structural work shall be done in accordance with the specifications. All structural work shall be done in accordance with the specifications. All structural work shall be done in accordance with the specifications. All structural work shall be done in accordance with the specifications. All structural work shall be done in accordance with the specifications. All structural work shall be done in accordance with the specifications. All structural work shall be done in accordance with the specifications. 	<p>MECHANICAL</p> <ol style="list-style-type: none"> All mechanical work shall be done in accordance with the specifications. All mechanical work shall be done in accordance with the specifications. All mechanical work shall be done in accordance with the specifications. All mechanical work shall be done in accordance with the specifications. All mechanical work shall be done in accordance with the specifications. All mechanical work shall be done in accordance with the specifications. All mechanical work shall be done in accordance with the specifications. All mechanical work shall be done in accordance with the specifications. 	<p>LANDSCAPE</p> <ol style="list-style-type: none"> All landscape work shall be done in accordance with the specifications. All landscape work shall be done in accordance with the specifications. All landscape work shall be done in accordance with the specifications. All landscape work shall be done in accordance with the specifications. All landscape work shall be done in accordance with the specifications. All landscape work shall be done in accordance with the specifications. All landscape work shall be done in accordance with the specifications. All landscape work shall be done in accordance with the specifications.
---	---	---	--

APPROVALS:

COUNTY WORKS OFFICER APPROVAL:	COUNTY PHYSICAL PLANNER APPROVAL:	PROJECT: AWAARSITU WATER PROJECT	CONSULTANTS: [Name]
COUNTY PUBLIC HEALTH OFFICER APPROVAL:	DRAWING TITLE: WATER KIOSK WITH TANK	DEVELOPER: COUNTY WATER OFFICE / WSP	DATE: [Date]

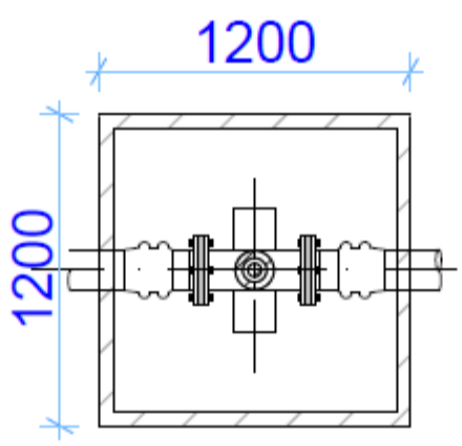

AIR VALVE
Plan & Cross Section of 50mm dia Air Valve Chamber

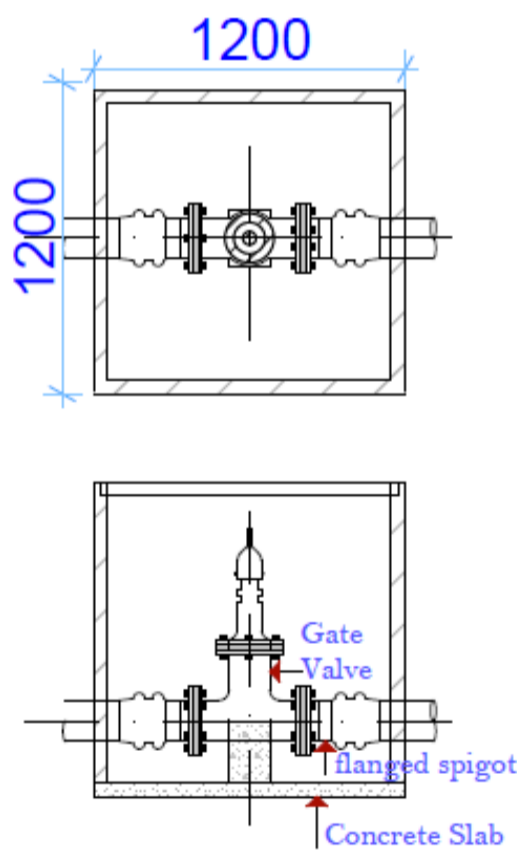

SLUICE VALVE
Plan & Cross Section of Sluice Valve Chamber

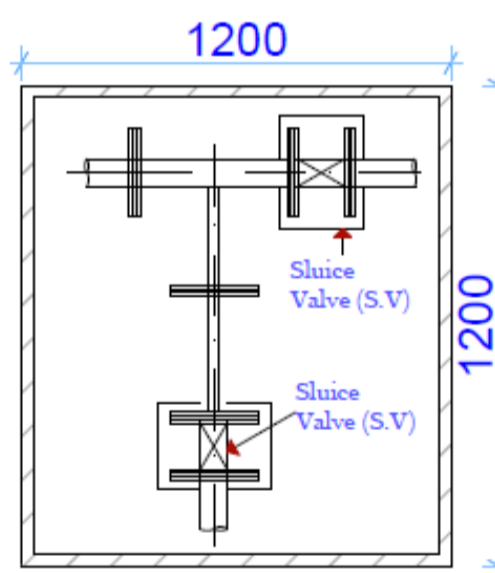

Plan of Junction Valve Chamber

NOTES

CONSTRUCTION

- All work shall be done in accordance with the specifications.
- All work shall be done in accordance with the specifications.
- All work shall be done in accordance with the specifications.
- All work shall be done in accordance with the specifications.
- All work shall be done in accordance with the specifications.
- All work shall be done in accordance with the specifications.
- All work shall be done in accordance with the specifications.
- All work shall be done in accordance with the specifications.

GENERAL

- The drawing is complete.
- All work shall be done in accordance with the specifications.
- All work shall be done in accordance with the specifications.
- All work shall be done in accordance with the specifications.
- All work shall be done in accordance with the specifications.
- All work shall be done in accordance with the specifications.
- All work shall be done in accordance with the specifications.
- All work shall be done in accordance with the specifications.

STRUCTURAL

- All structural work shall be done in accordance with the specifications.
- All structural work shall be done in accordance with the specifications.
- All structural work shall be done in accordance with the specifications.
- All structural work shall be done in accordance with the specifications.
- All structural work shall be done in accordance with the specifications.
- All structural work shall be done in accordance with the specifications.
- All structural work shall be done in accordance with the specifications.
- All structural work shall be done in accordance with the specifications.

MECHANICAL

- All mechanical work shall be done in accordance with the specifications.
- All mechanical work shall be done in accordance with the specifications.
- All mechanical work shall be done in accordance with the specifications.
- All mechanical work shall be done in accordance with the specifications.
- All mechanical work shall be done in accordance with the specifications.
- All mechanical work shall be done in accordance with the specifications.
- All mechanical work shall be done in accordance with the specifications.
- All mechanical work shall be done in accordance with the specifications.

LANDSCAPE

- All landscape work shall be done in accordance with the specifications.
- All landscape work shall be done in accordance with the specifications.
- All landscape work shall be done in accordance with the specifications.
- All landscape work shall be done in accordance with the specifications.
- All landscape work shall be done in accordance with the specifications.
- All landscape work shall be done in accordance with the specifications.
- All landscape work shall be done in accordance with the specifications.
- All landscape work shall be done in accordance with the specifications.

DISTRICT WATER OFFICE
P.O. BOX 580-60300
ISOLO

PROJECT: KIPSING WATER SUPPLY PROJECT
CLIENT: CATHOLIC DIOCESE OF ISOLO

SHEET TITLE: Valve Chambers

DATE: [Date]